



**BELGARD**<sup>®</sup>  
PAVES THE WAY<sup>™</sup>

INSTALLATION GUIDE  
**ARTFORMS**<sup>™</sup>  
Modular Panel System

# TABLE OF CONTENTS

Click on the application of your choice to see the detail page 

SYSTEM OVERVIEW

INSTALLATION



**SCAN HERE**  
TO SEE SOME  
ARTFORMS™ BUILDS  
IN BELGARD ROOMS

## Parts List | Concrete Panels

**18 x 36 x 3" (150 lb)**

457 x 914 x 76 mm (67 kg)

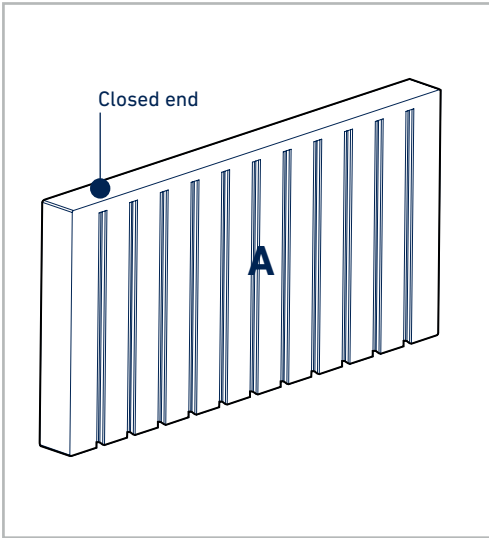

**18 x 36 x 3" (148 lb)**

457 x 914 x 76 mm (66 kg)

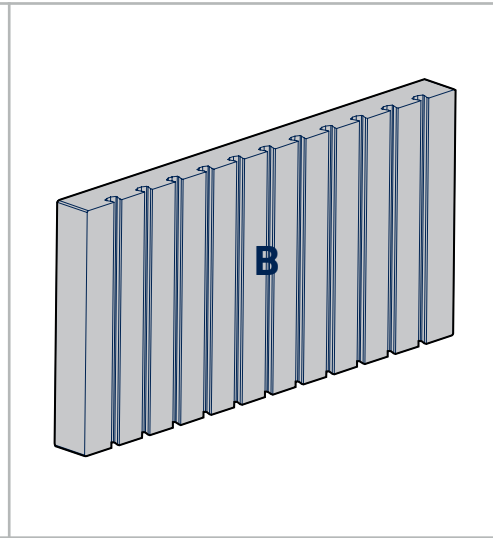

**\*40 x 48" Pallet (18 units/pallet)**

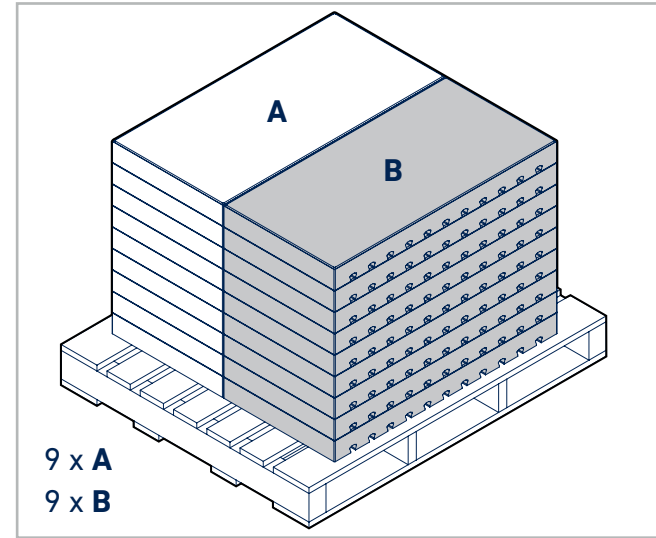

**6 x 36 x 3" (49 lb)**

152 x 914 x 76 mm (22 kg)

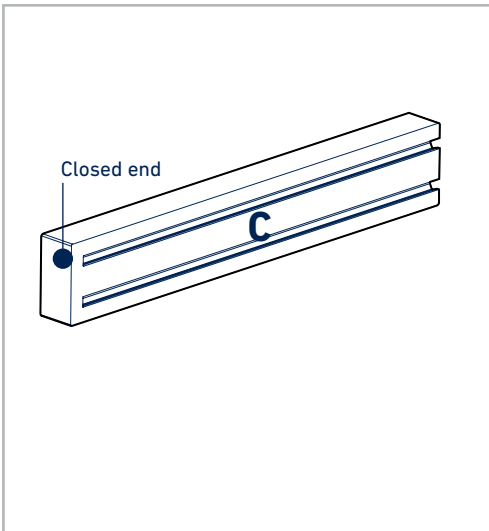

**6 x 36 x 3" (49 lb)**

152 x 914 x 76 mm (22 kg)

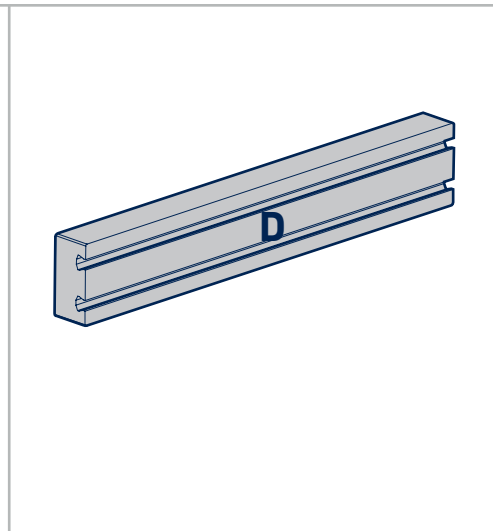

**\*40 x 48" Pallet (21 units/pallet)**

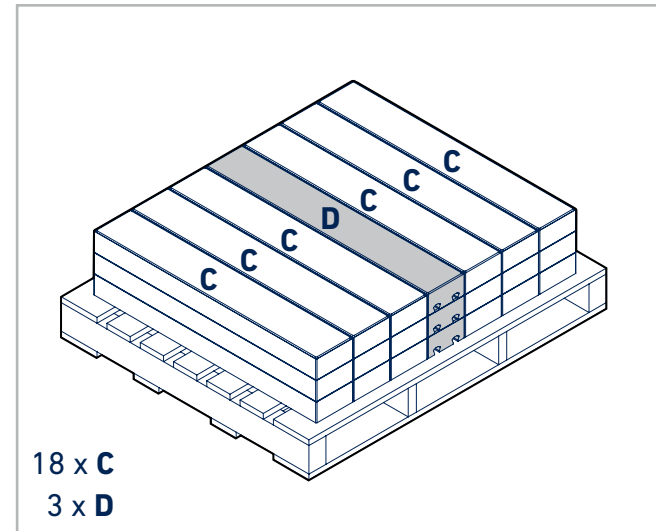

**\*IMPORTANT:** 18x36" panels are sold in pair/layer or in full pallet only. 6x36" panels are sold per unit or in layer or in full pallet.

## Parts List | Hardware (stainless steel)

### Anchor Slide – ¼" x 20 stud & nut

2 x 1¼ x 1" (51 x 33 x 25 mm)

0.1 lbs (0.05 kg)

50 units/box

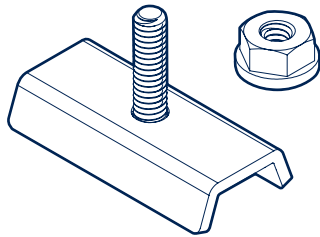

### Joining Plate

8¼ x 2½ x 1½" (209 x 63 x 38 mm)

1 lbs (0.5 kg)

10 units/box

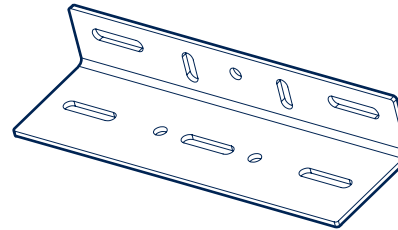

### Inner Corner

9 x 6 x 2½" (232 x 155 x 63 mm)

1.5 lbs (0.7 kg)

10 units/box

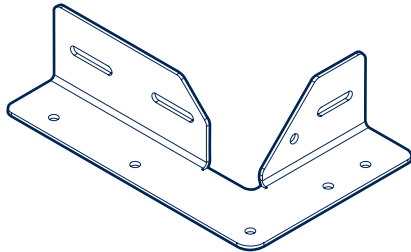

### Outer Corner

4 x 4 x 2½" (101 x 101 x 63 mm)

0.9 lbs (0.4 kg)

10 units/box

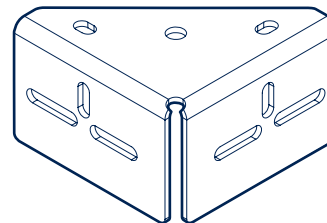

### Stretcher Bar

36¾ x 1¼ x 1" (933 x 33 x 25 mm)

2 lbs (0.9 kg)

10 units/box

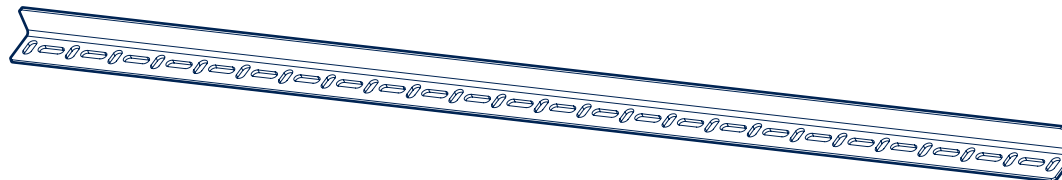

## Tools & Safety Equipment

### REQUIRED TOOLS

**Drill**

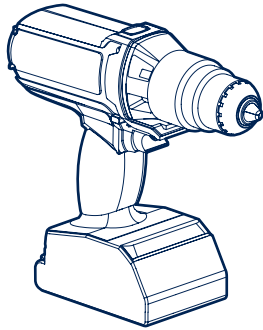

**Mallet**



**Measuring  
tape**

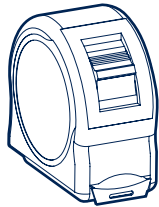

**Saw**

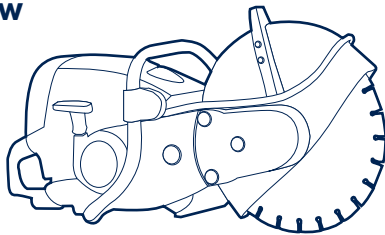

**Level**

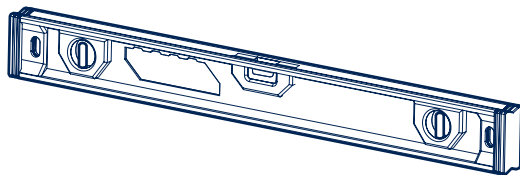

**Deep Hex Socket  
7/16" with 1/4"  
Drive**

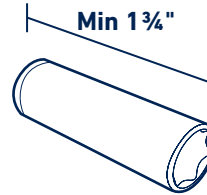

**Socket Adapter  
1/4" Hex shank to  
1/4" Drive**

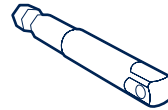

**Chipping  
Hammer**

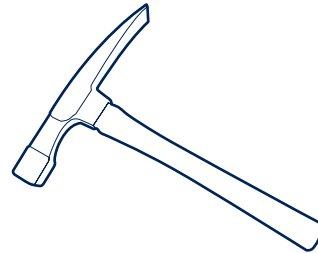

**Bar Clamp (48")**

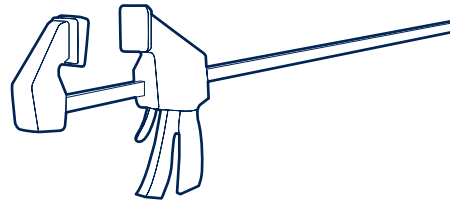

**Plastic shims**

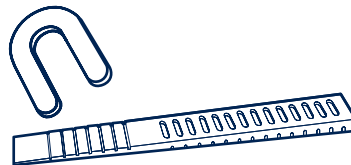

### SAFETY EQUIPMENT

**Safety boots**



**Gloves**



**Safety glasses**

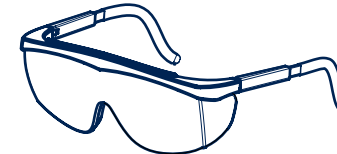

**Mask**



# Applications

1.



PLANTER BOX &amp; BENCH

4.

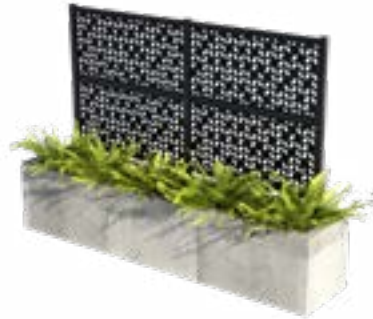

PLANTER BOX &amp; PRIVACY WALL

7.



RAISED GARDEN

2.



\* FIRE PIT

5.



WATERFALL

8.



FLOATING STEPS

3.



\* ARGENTINE GRILL ISLAND

6.



\* GRILL ISLAND

9.



COUNTER ISLAND

**\* IMPORTANT:** For all complementary appliances/accessories to the **Artforms panel system**, follow manufacturer's instructions/guidelines. Consult qualified services person/ experts to validate installations, repairs, safety recommendations and any other related topics.

# Modularity | The System

**18 x 36 x 3" PANEL**

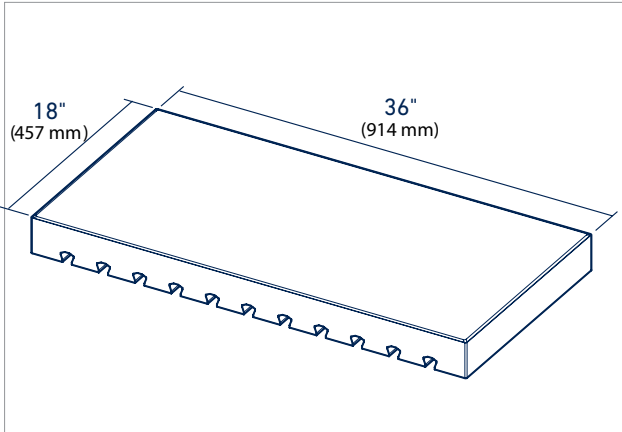

**6 x 36 x 3" PANEL**

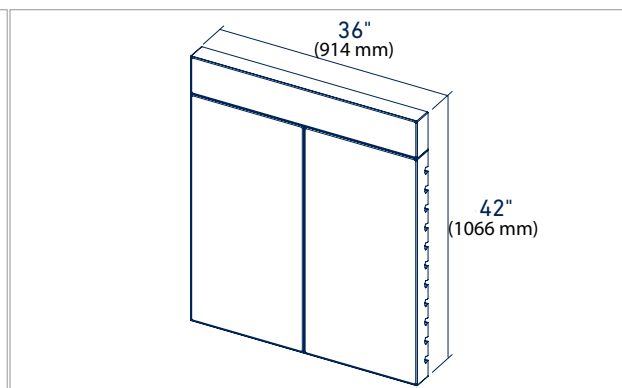
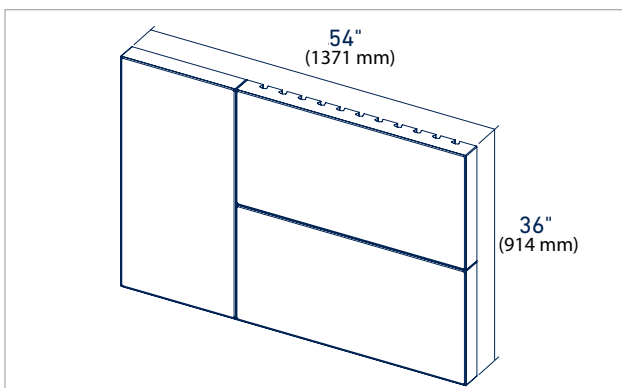
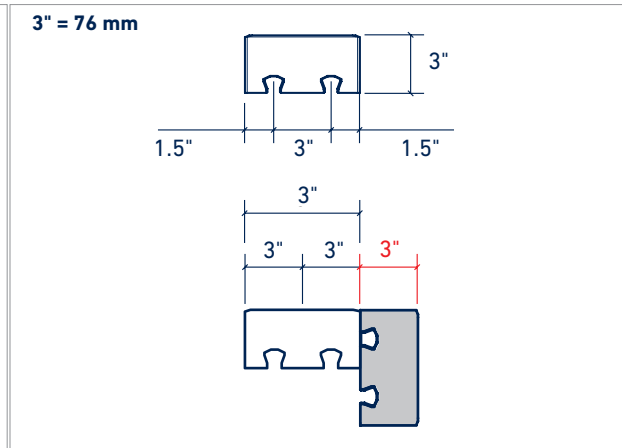
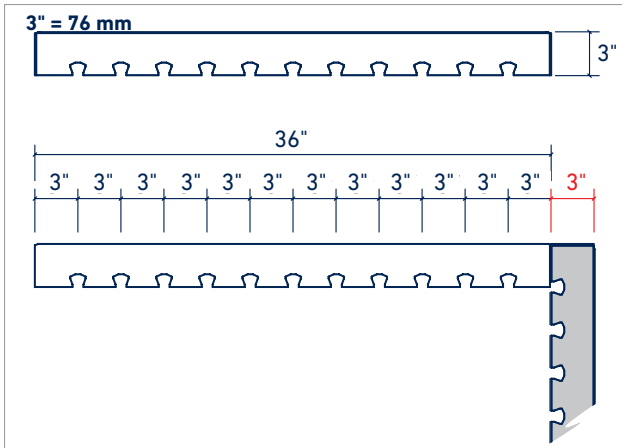
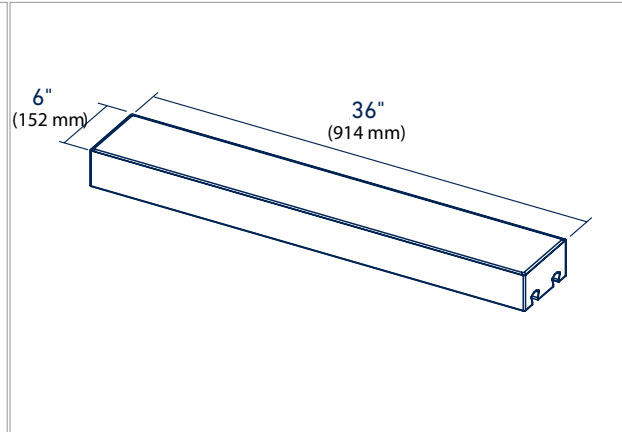

**RECOMMENDED :  
CUT IN THE MIDDLE OF  
DOVETAIL**

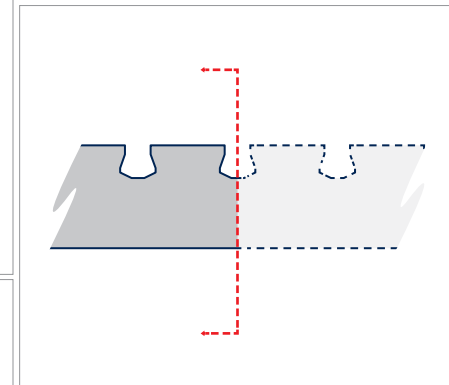

**ADJUSTMENT**

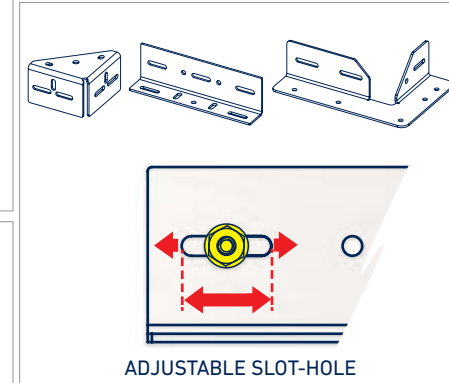

**NOTE:** It is recommended to design structures with overall dimensions using increments of 3" (76mm).

## Modularity | References

### KITCHEN TABLE



### BAR TABLE

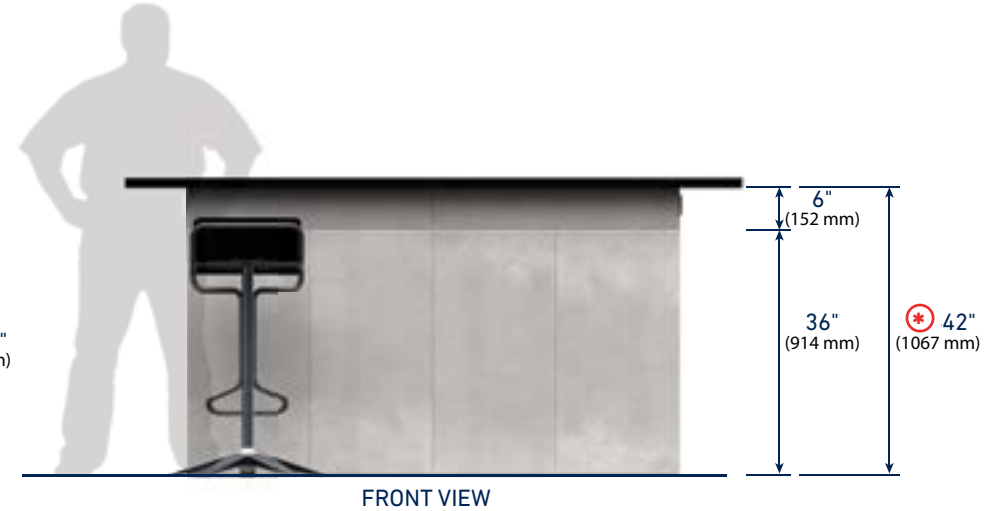

### SEATING

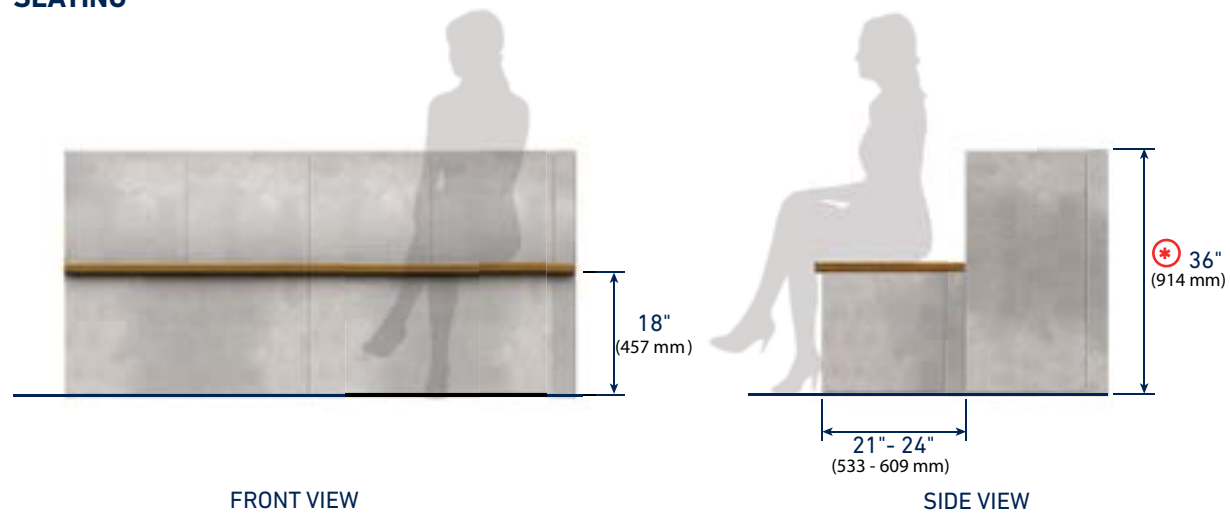

**\* NOTE:** Maximum height of **36"** for planter box and **42"** for outdoor living structure. Any higher structure must be designed by an engineer.

## Panel Configurations

Coping can be used to hide the dovetails.

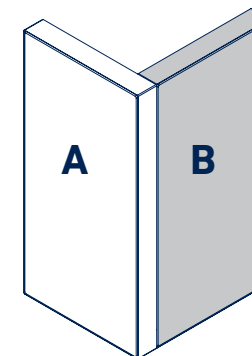
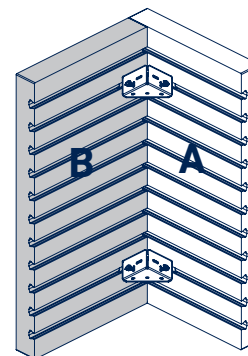
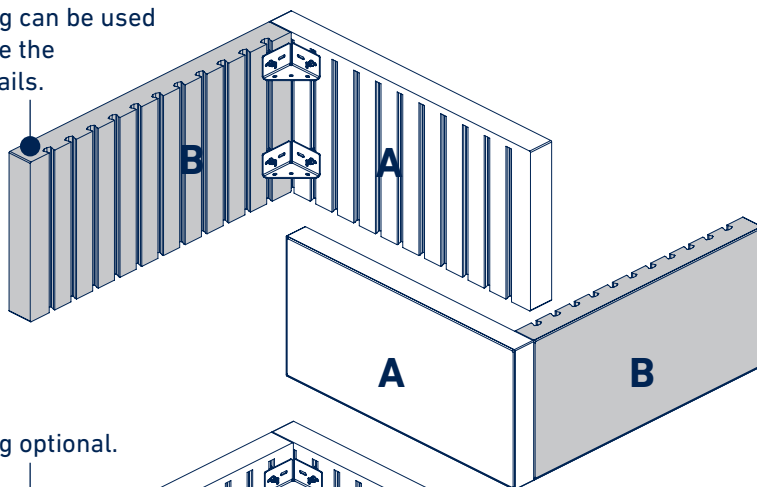

**\* IDEAL:**  
 This configuration uses equal number of panel A and panel B.

Coping optional.

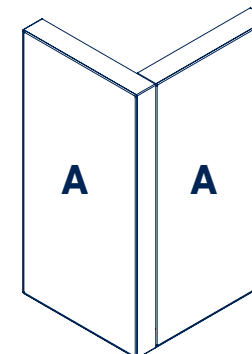
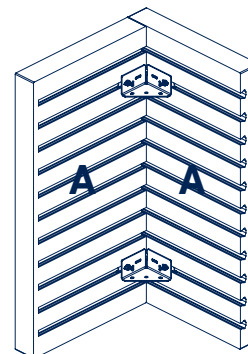
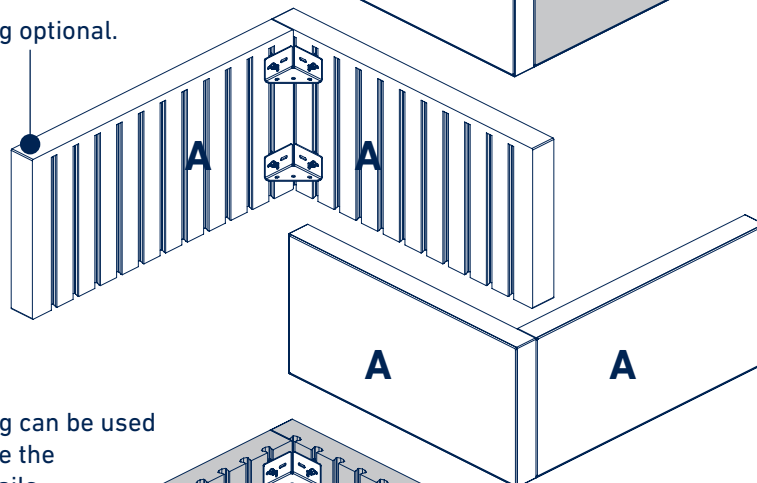

**\* NOT OPTIMAL:**  
 This configuration uses panel A only.

Coping can be used to hide the dovetails.

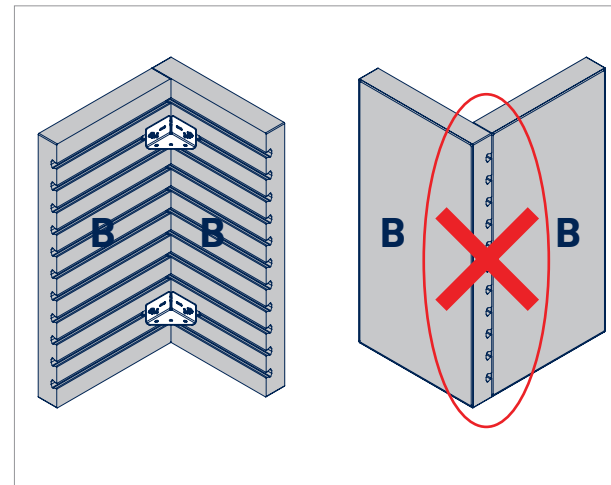
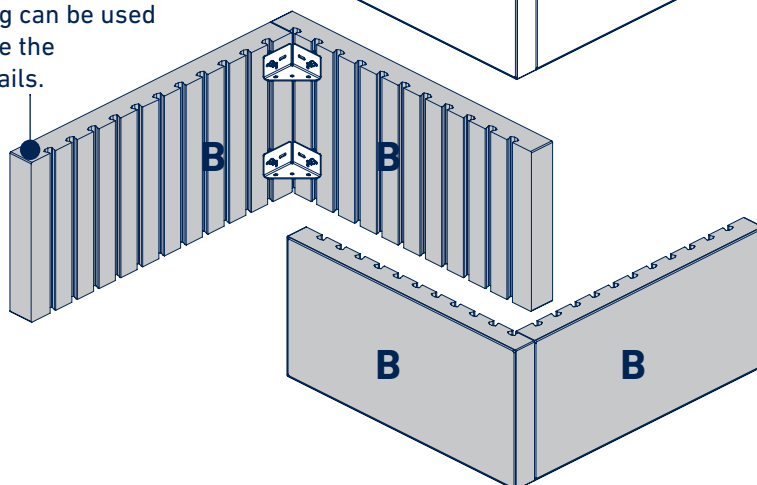

**\* NOT RECOMMENDED:**  
 This configuration uses panel B only and the dovetails are exposed. Use ideal configuration as shown above.

**\*IMPORTANT:** When planning configurations, consider the amount of panel A and panel B on a pallet. 18x36" panels are sold in pair/layer or in full pallet only. 6x36" panels are sold in layer or in full pallet only.

## Outer Corner Installation

### HORIZONTAL PANELS

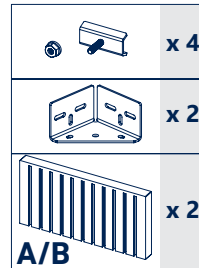
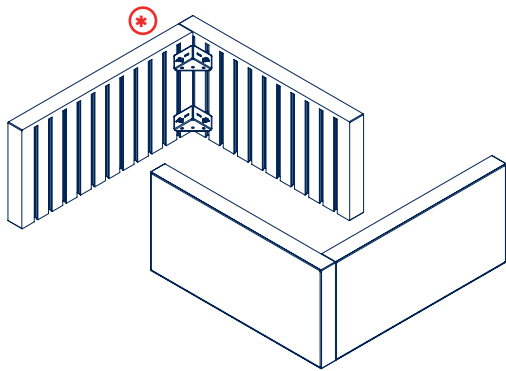

### VERTICAL PANELS

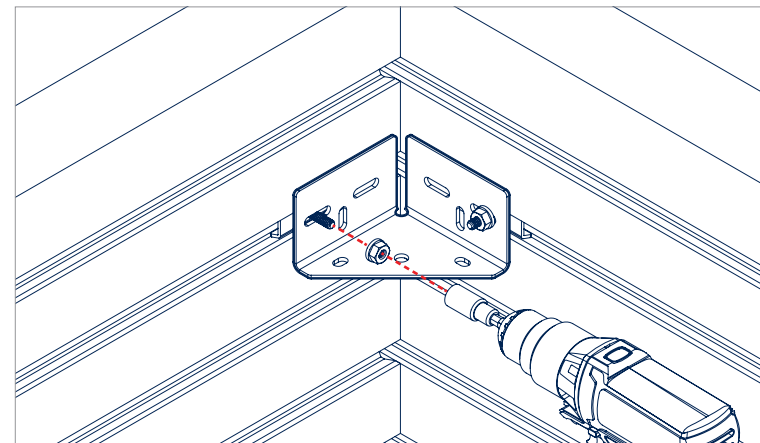
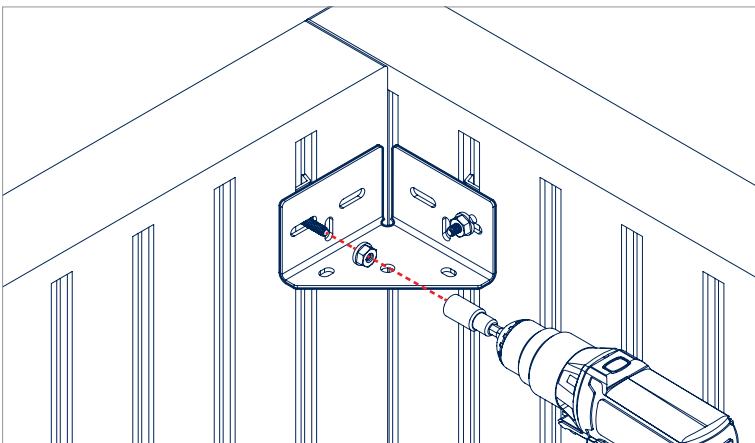
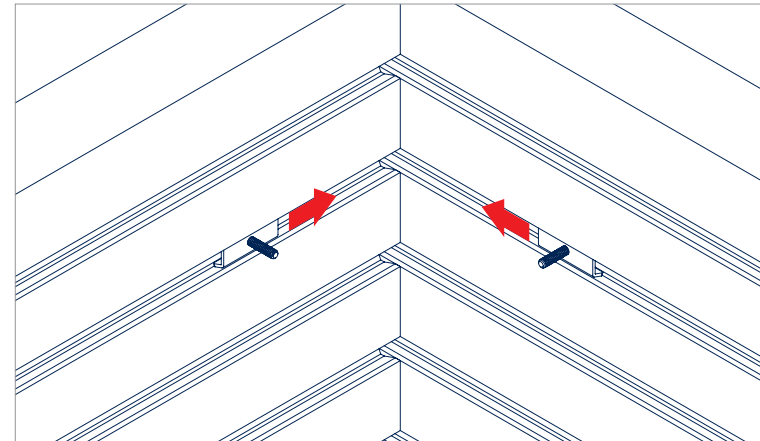
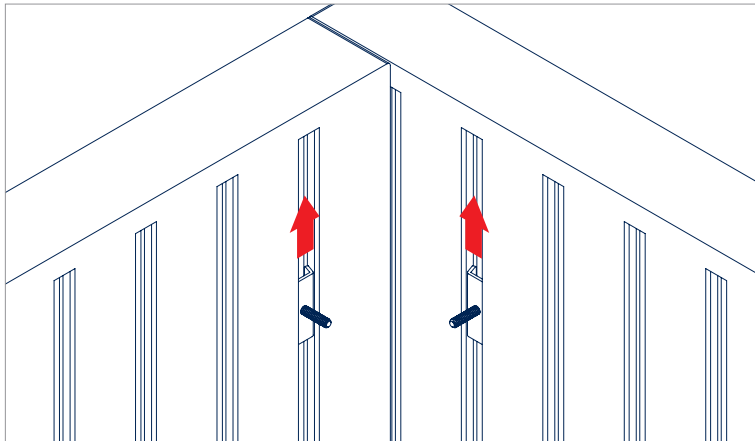
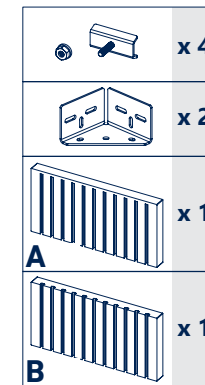
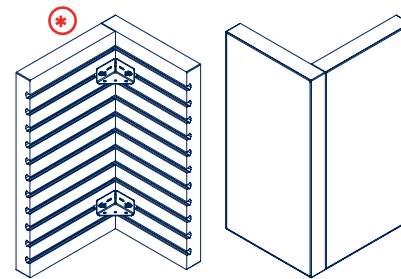

**⚠ IMPORTANT:** Always use a minimum of 2 outer corner brackets per corner assembly.  
 ▶ See Tips and Tricks from page 27 for more details.

# Inner Corner Installation

## HORIZONTAL PANELS

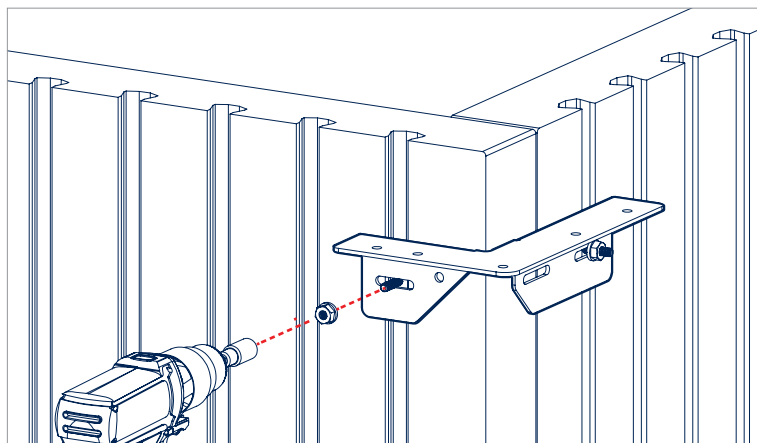
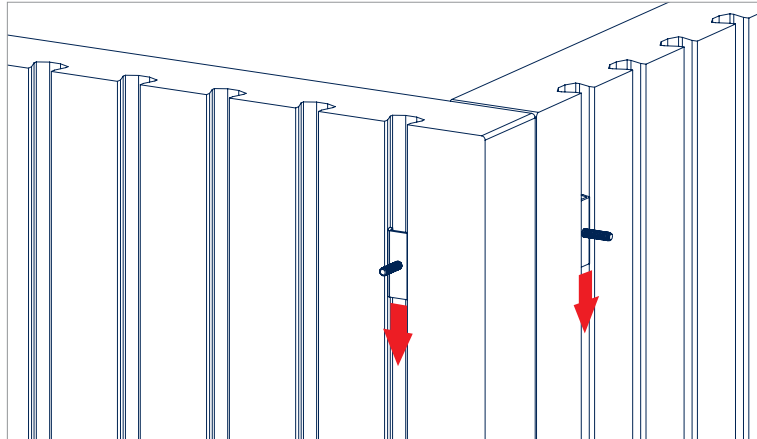
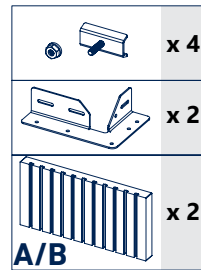
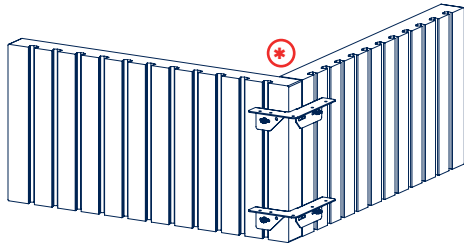

## VERTICAL PANELS

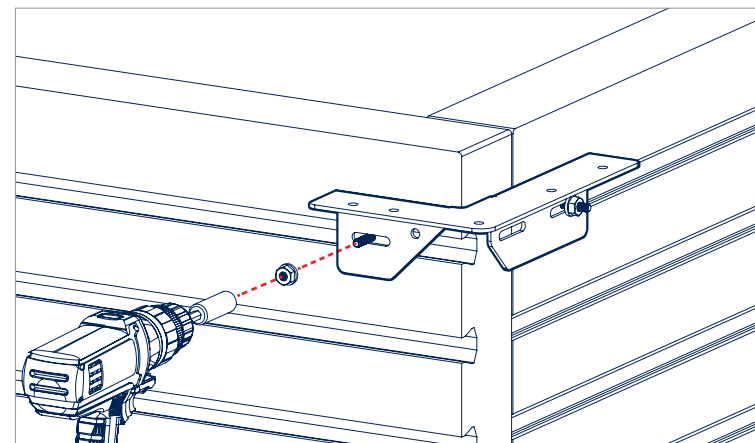
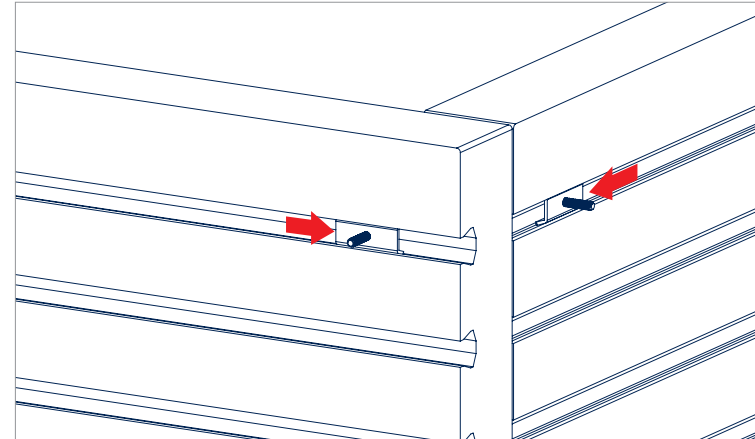
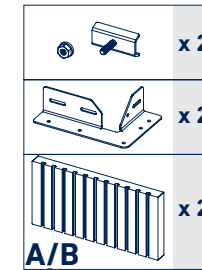
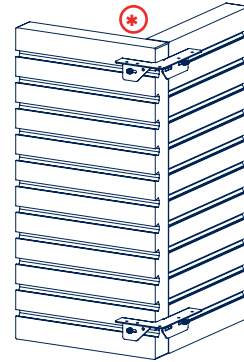

**⚠ IMPORTANT:** Always use a minimum of 2 inner corner brackets per corner assembly.  
 ▶ See Tips and Tricks from page 27 for more details.

## Joining Plate Installation

### HORIZONTAL PANELS

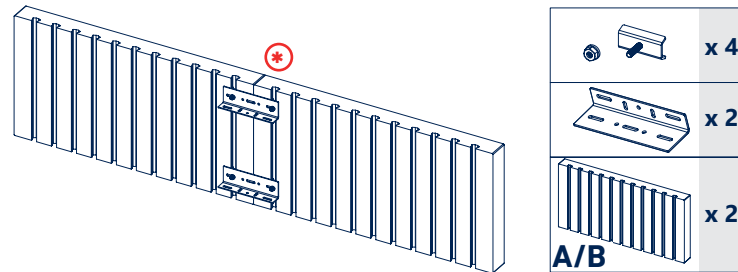

### VERTICAL PANELS

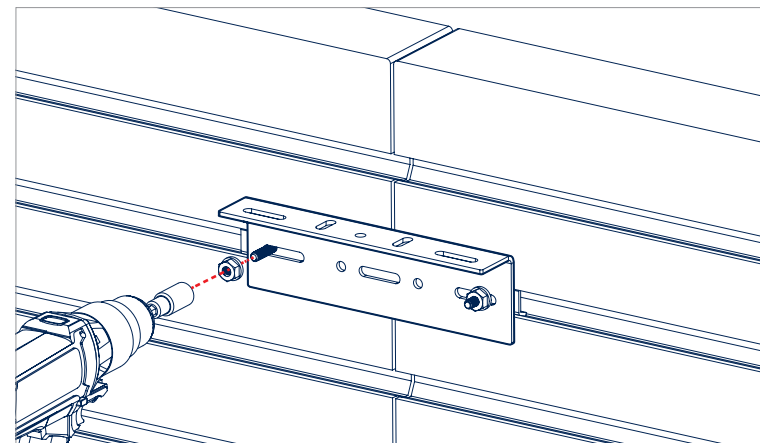
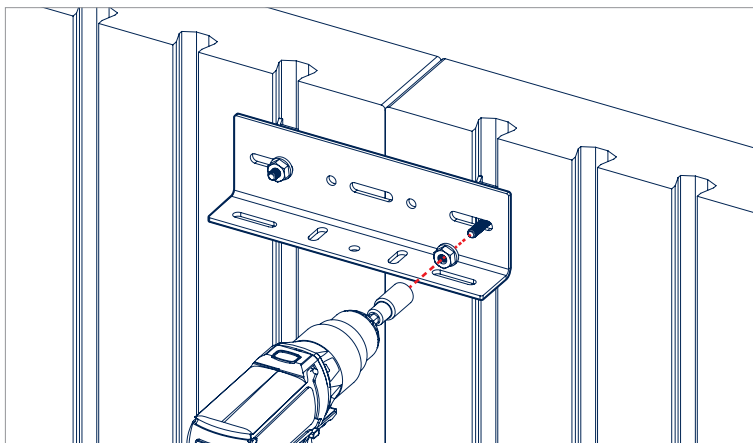
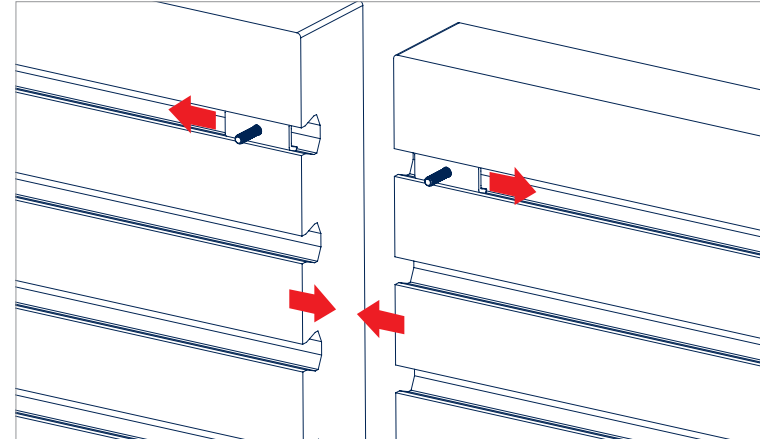
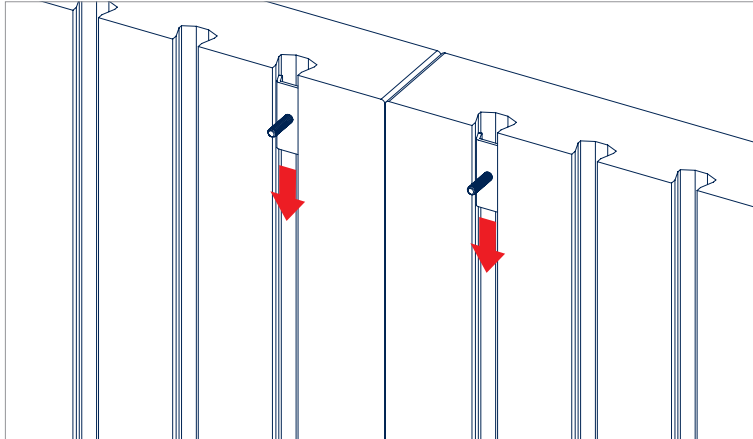
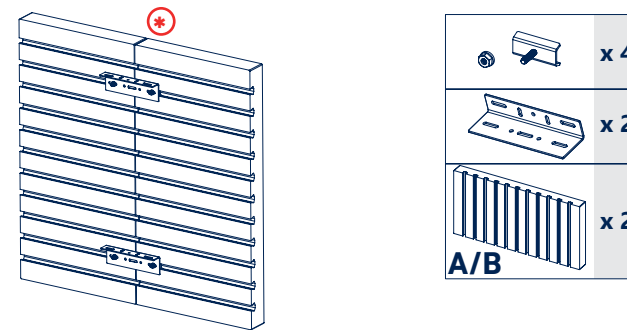

**⚠ IMPORTANT:** Always use a minimum of 2 joining plates when joining two parallel panels.  
 ▶ See Tips and Tricks from page 27 for more details.

# Stretcher Bar Installation

## HORIZONTAL PANELS

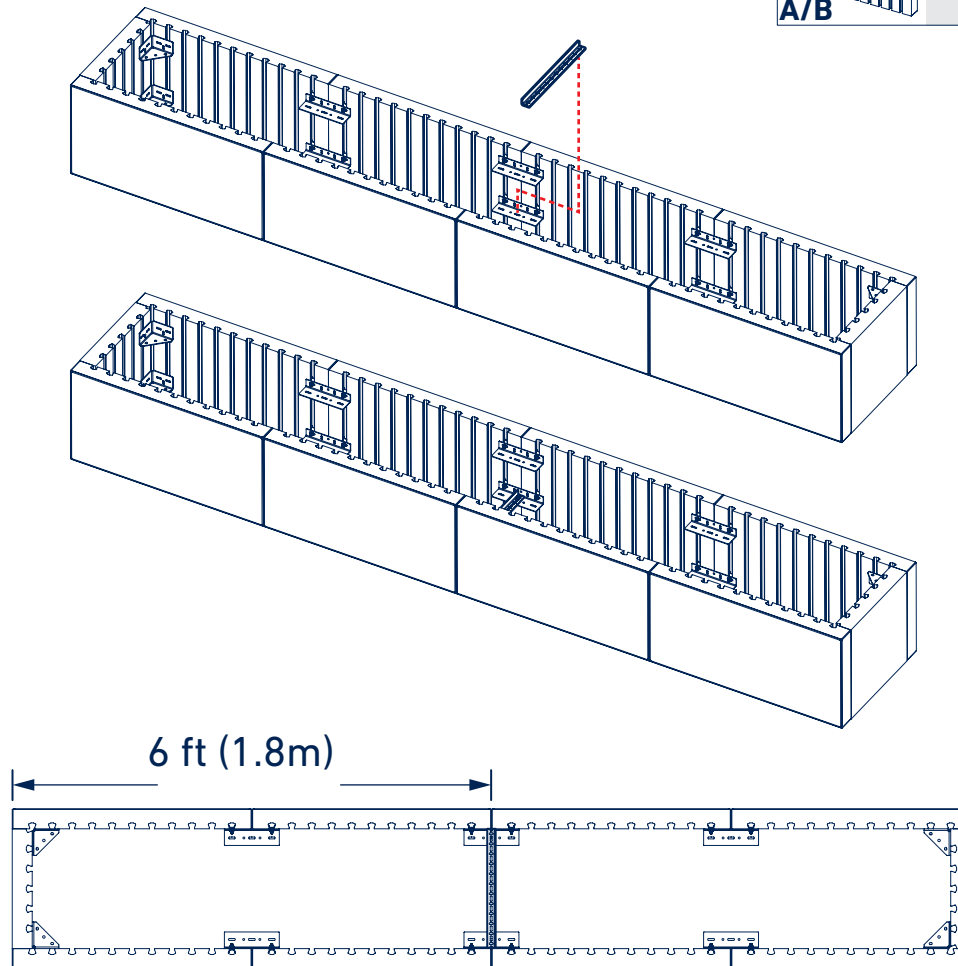
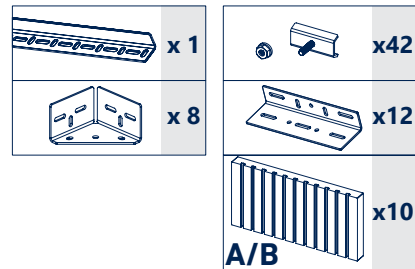

The stretcher bar provides structure to keep 2 sets of facing panels in parallel alignment. It is recommended to attach the stretcher bar to the joining plate every 6ft (1.8m). Place it at 1/3 of the total height from the bottom of assembly.

The stretcher bar must be cut to fit distance between 2 sets of panels.

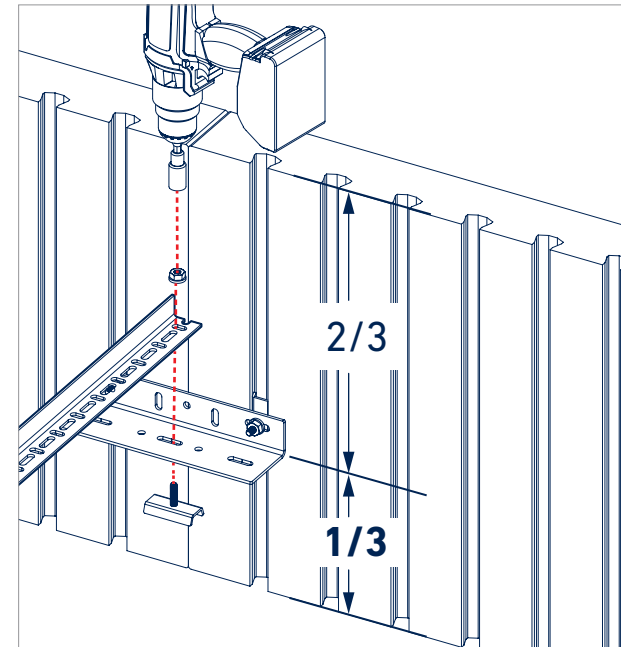

**NOTE:** The stretcher bar can be extended.

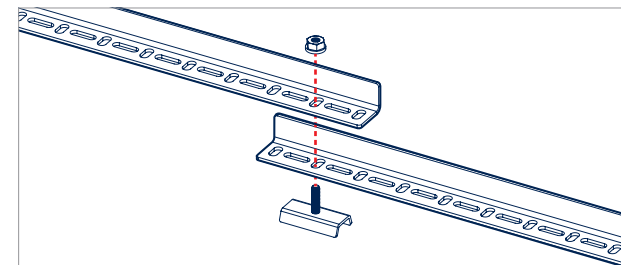

► See Tips and Tricks from page 27 for more details.

## Stretcher Bar Installation

### VERTICAL PANELS

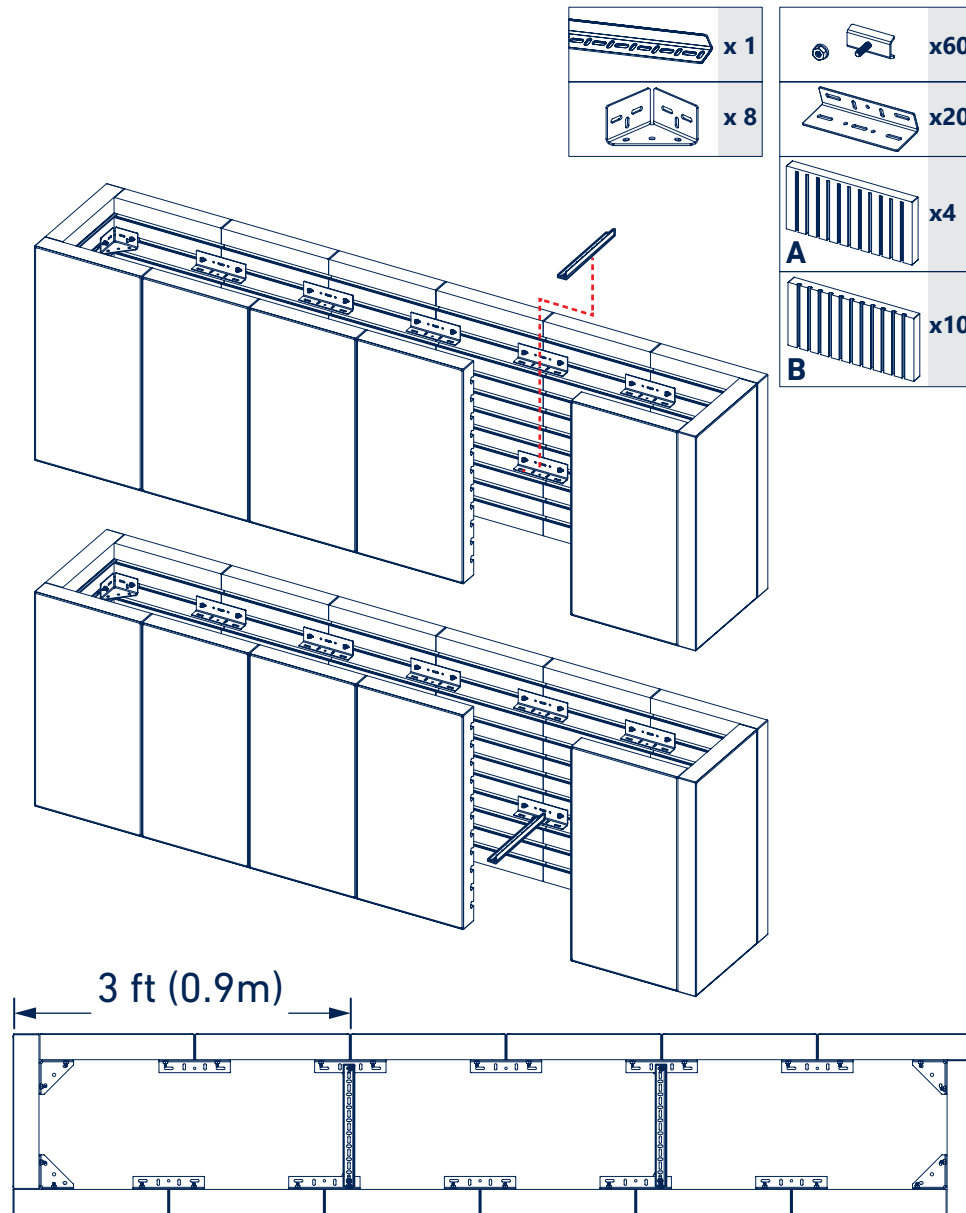

The stretcher bar provides structure to keep 2 sets of facing panels in parallel alignment. It is recommended to attach the stretcher bar to the joining plate every 3ft (0.9m). Place it at approximately 1/3 of the total height from the bottom of assembly.

The stretcher bar must be cut to fit distance between 2 sets of panels.

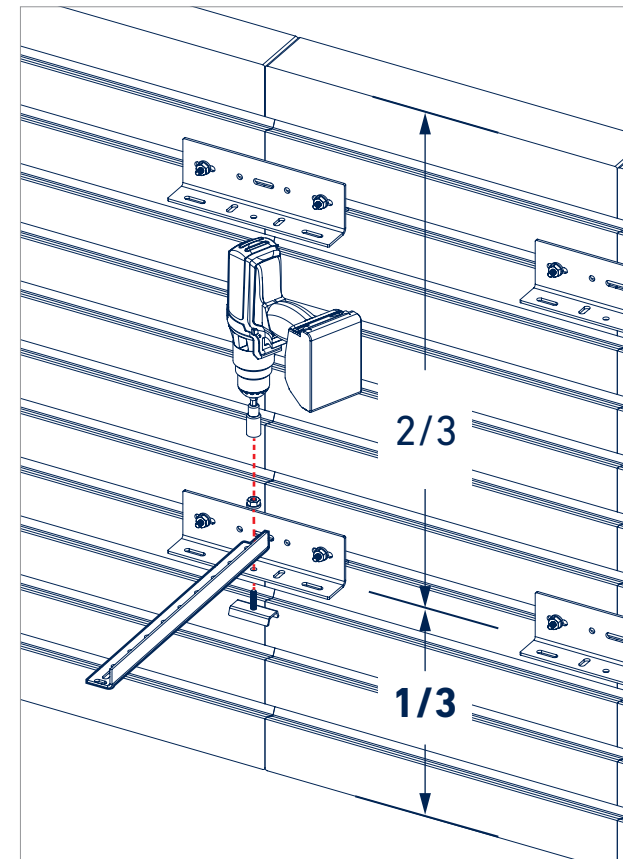

► See Tips and Tricks from page 27 for more details.

# 3 X 36 Panel | Coping Installation (mechanically fixed)

18 x 36 x 3" HORIZONTAL PANELS

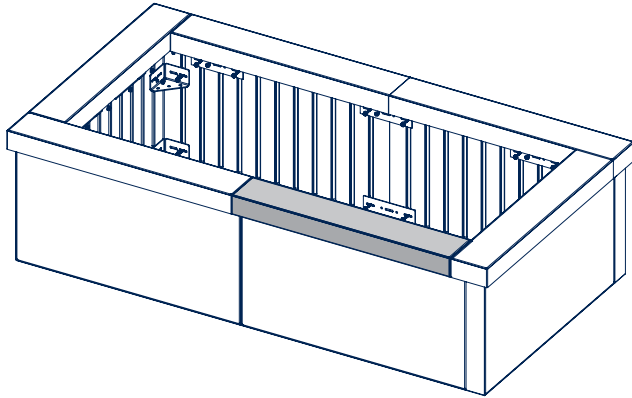

18 x 36 x 3" VERTICAL PANELS

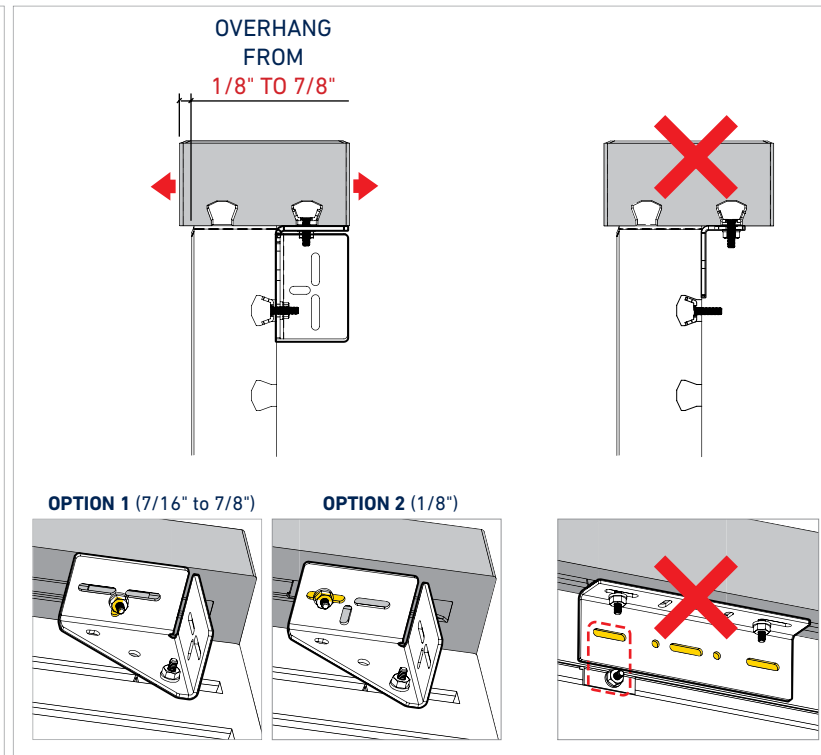
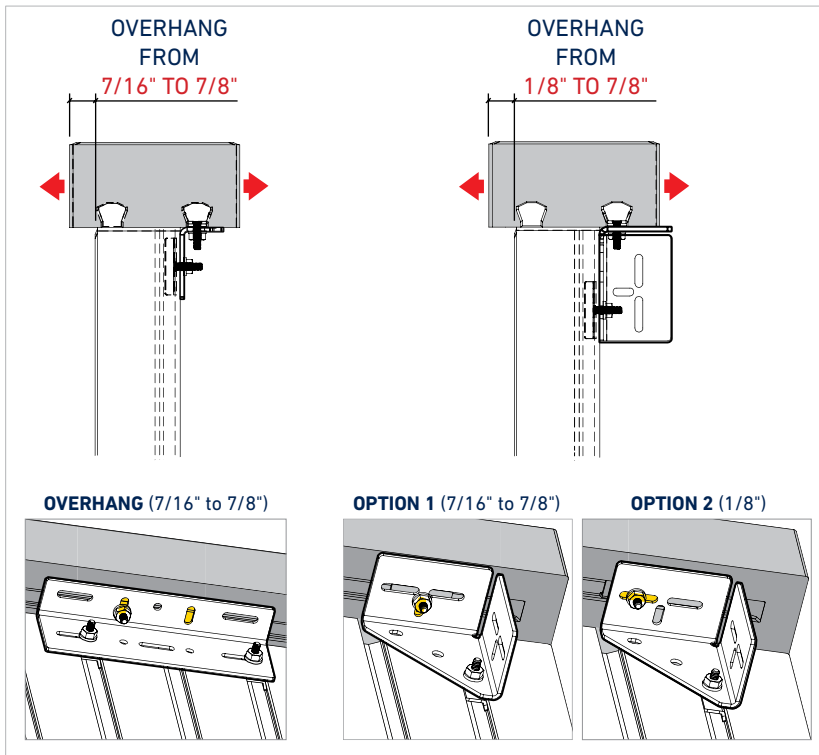
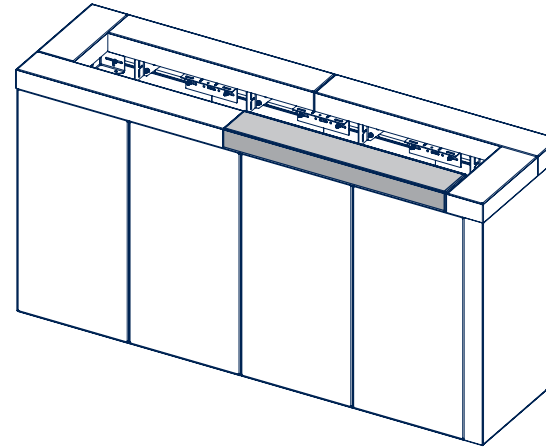

► See Tips and Tricks from page 27 for more details.

## 3 X 36 Panel | Coping Installation (Fixed with adhesive)

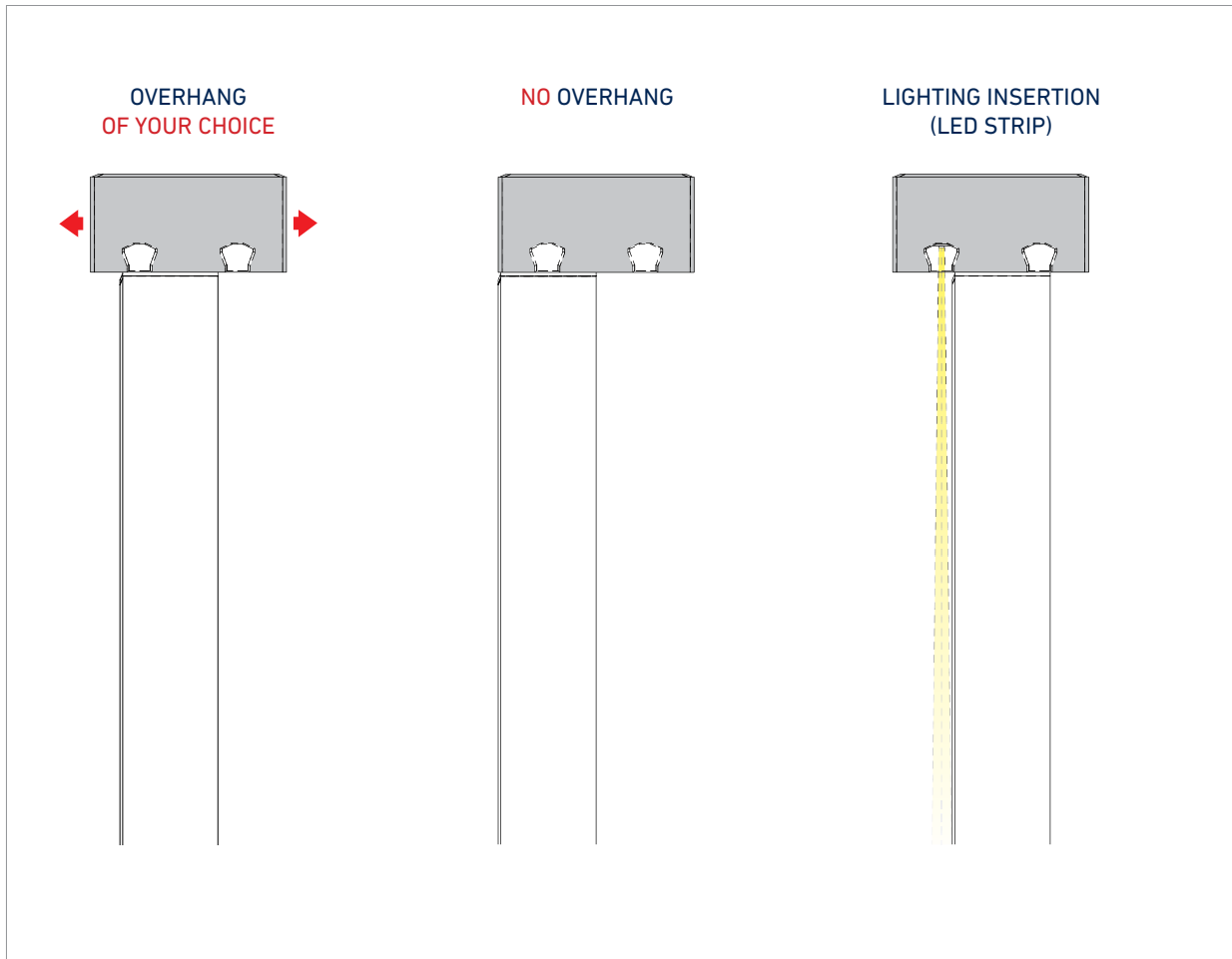

**Affix Coping with  
Construction Glue or  
Techniseal® Structure Bond™**

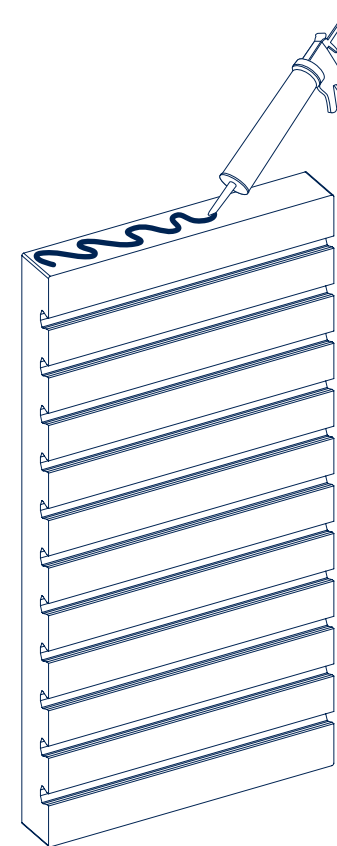

## 3 X 36 Panel | Accent Installation

6 x 36 x 3" PANEL

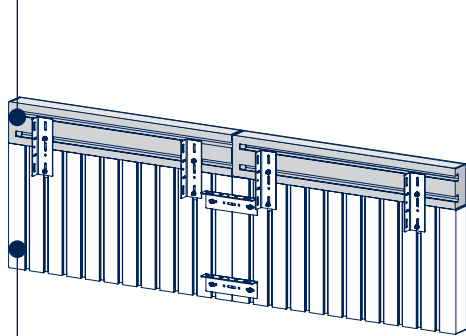

18 x 36 x 3" HORIZONTAL PANEL

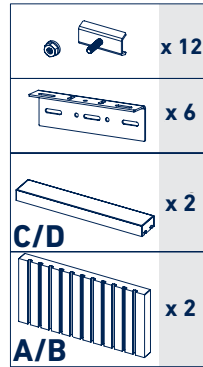

6 x 36 x 3" PANEL

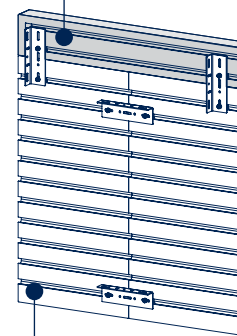

18 x 36 x 3" VERTICAL PANEL

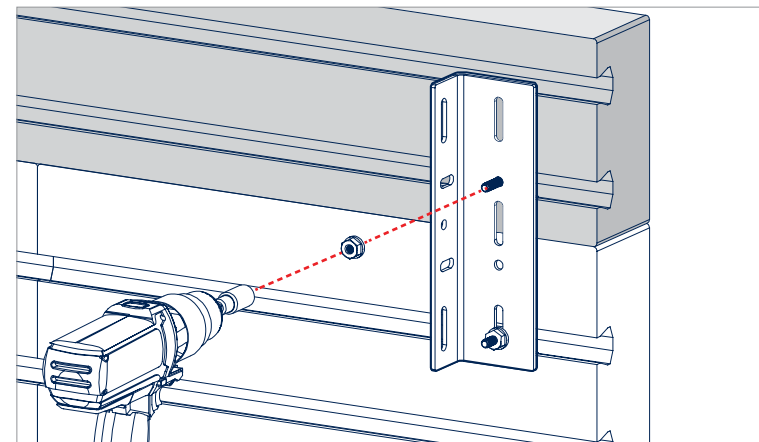
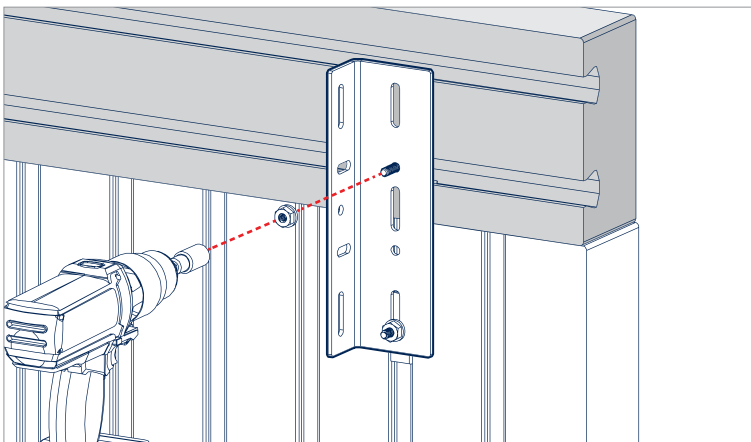
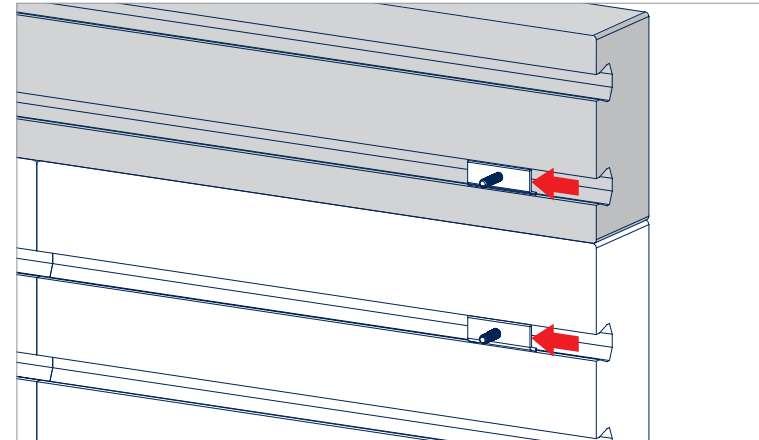
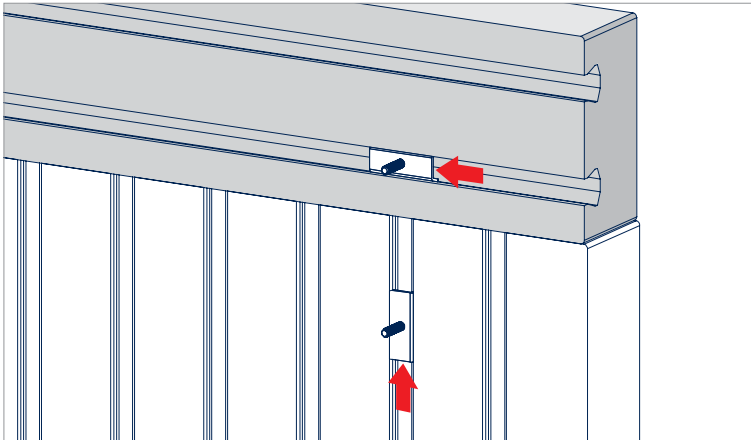
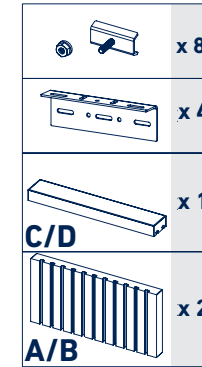

**⚠ IMPORTANT:** Always use a minimum of 2 joining plates when joining 6x36 panel with 18x36 panel  
 ▶ See Tips and Tricks from page 27 for more details.

# Integrating Wood

## BENCH

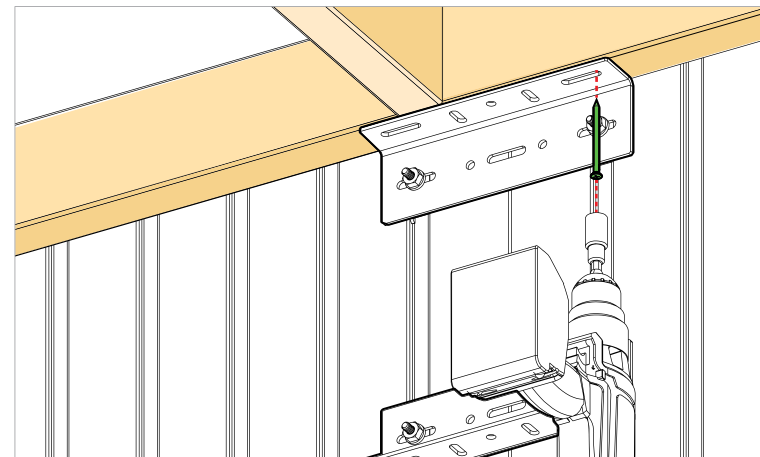
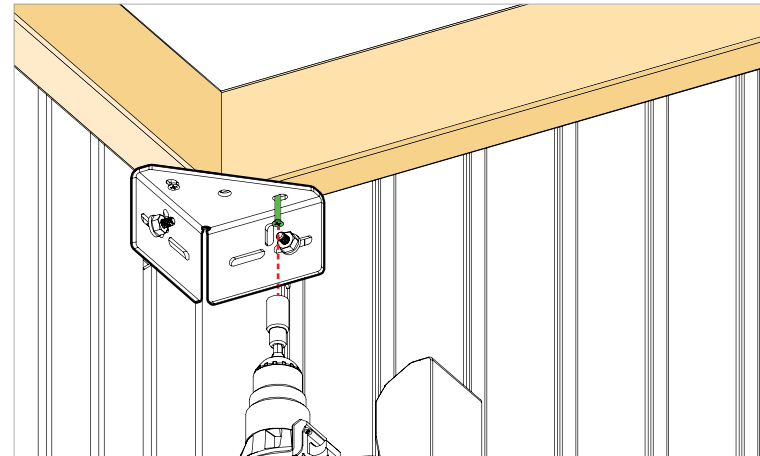
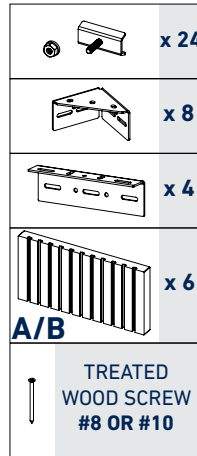
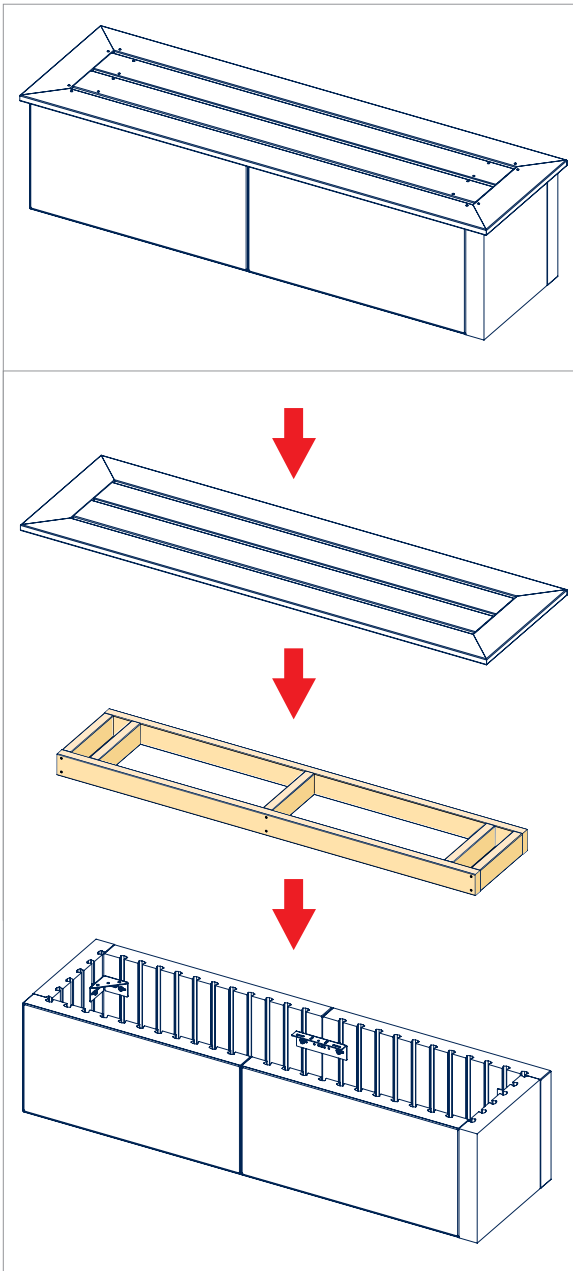

INSTALL THE HARDWARE ACCORDING TO WOOD SIZE

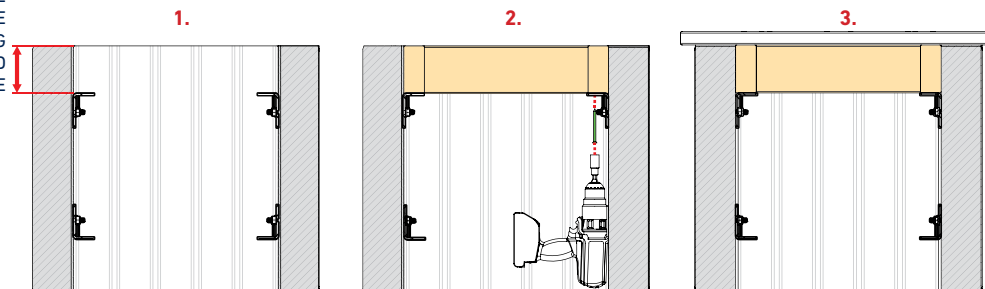

► See Tips and Tricks from page 27 for more details.

# Integrating 4 x 4" Wood Posts

## HORIZONTAL PANELS

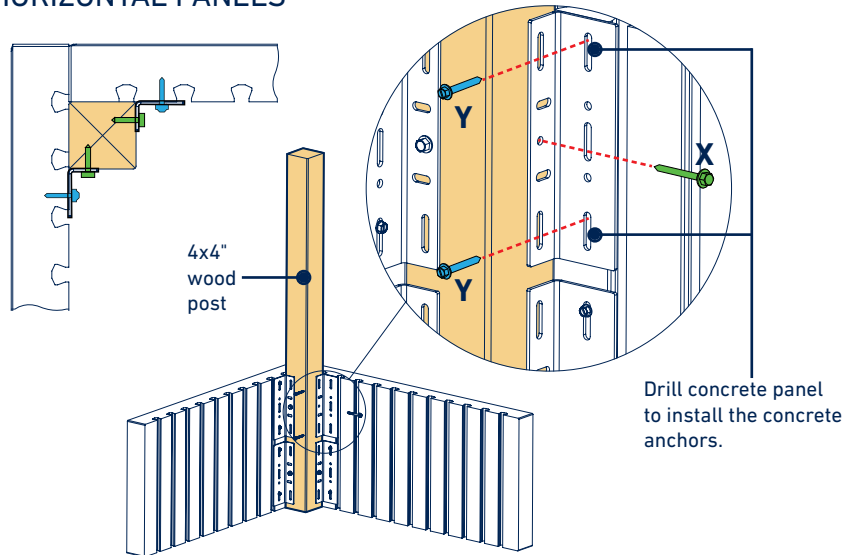

## VERTICAL PANELS

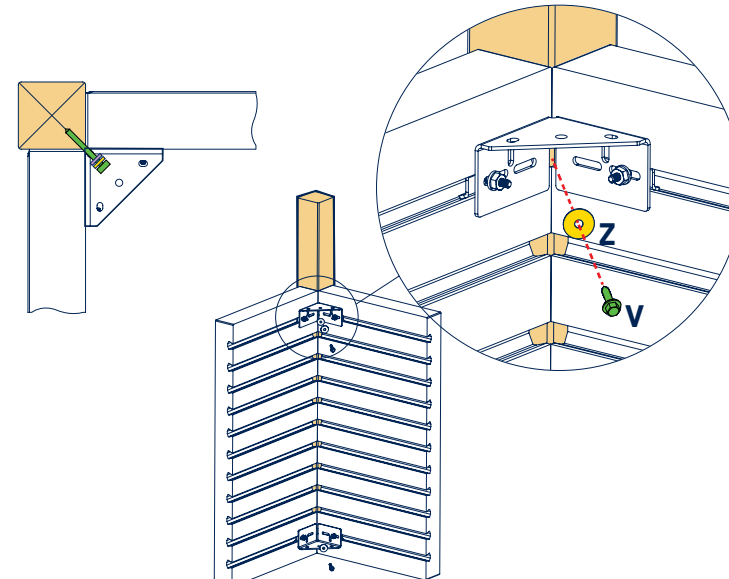
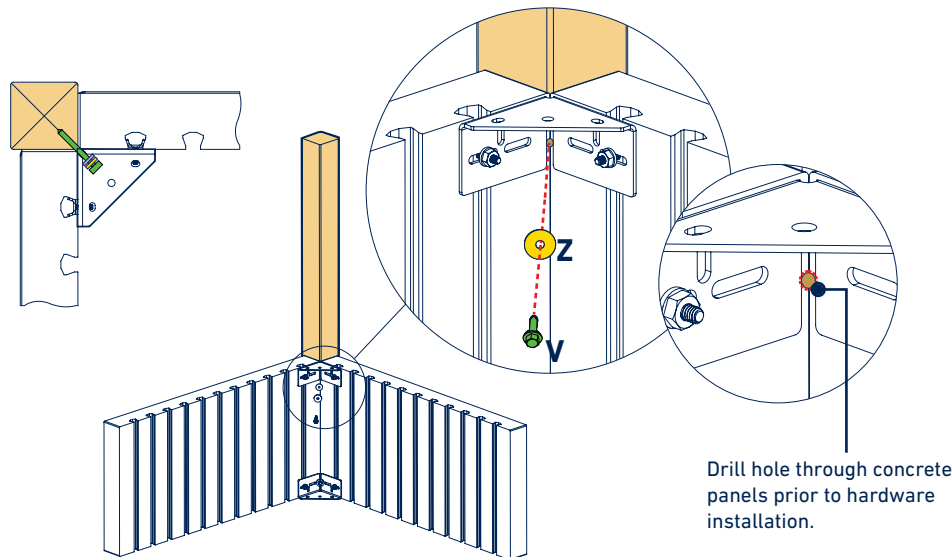
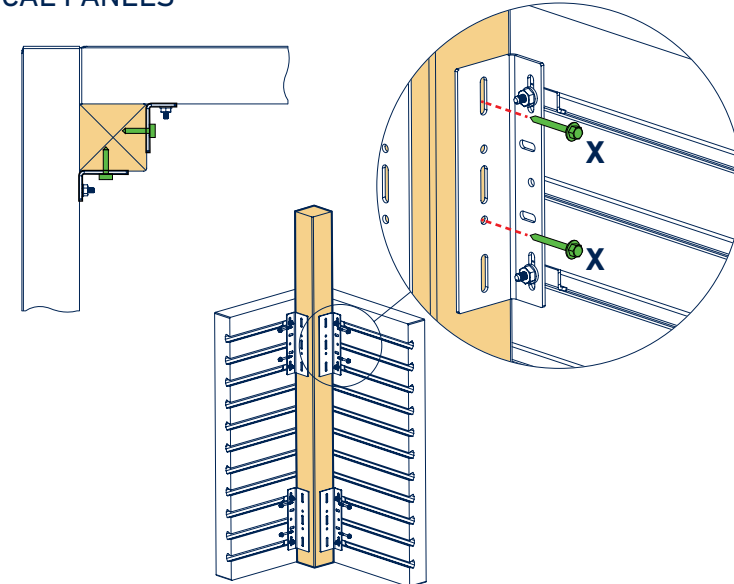

**X=Stainless Steel Wood Screw Flat Head #10 x 2½"**

**V=Stainless Steel Lag screws 1/4 x 2½" or 5/16 x 2½"**

**Y=Treated Concrete Anchor (Tapcon®) 1/4"x1¾" or 3/16"x1¾" Z=Stainless Steel Oversized Washer 5/16"**

**IMPORTANT:** Other types of hardware (not included) may be required to make these assemblies (wood screws, concrete anchors, etc.).

**BELGARD** is not responsible for any issue regarding other materials, accessories, other types of hardware, etc. *We recommend consulting an expert or engineer to determine the design limitations of the screen panels based on wind loads.*

## Integrating 4 x 4" Wood Posts

### HORIZONTAL PANELS

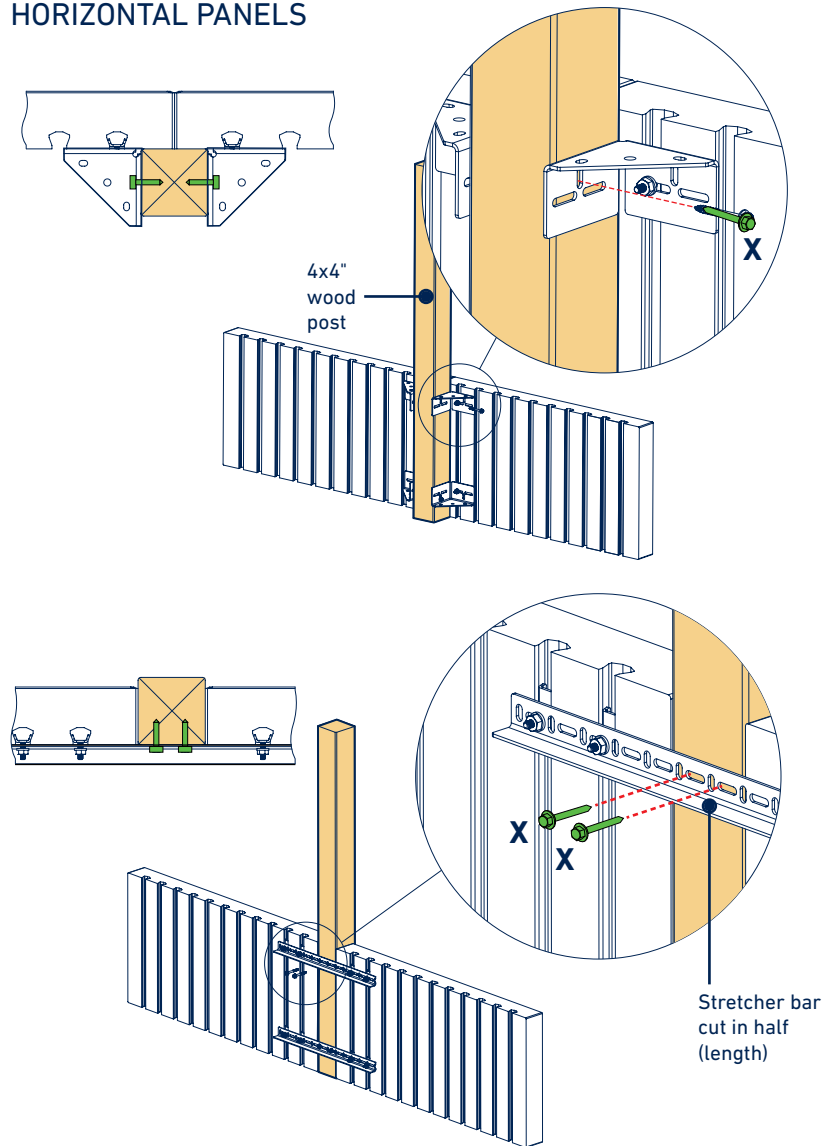

### VERTICAL PANELS

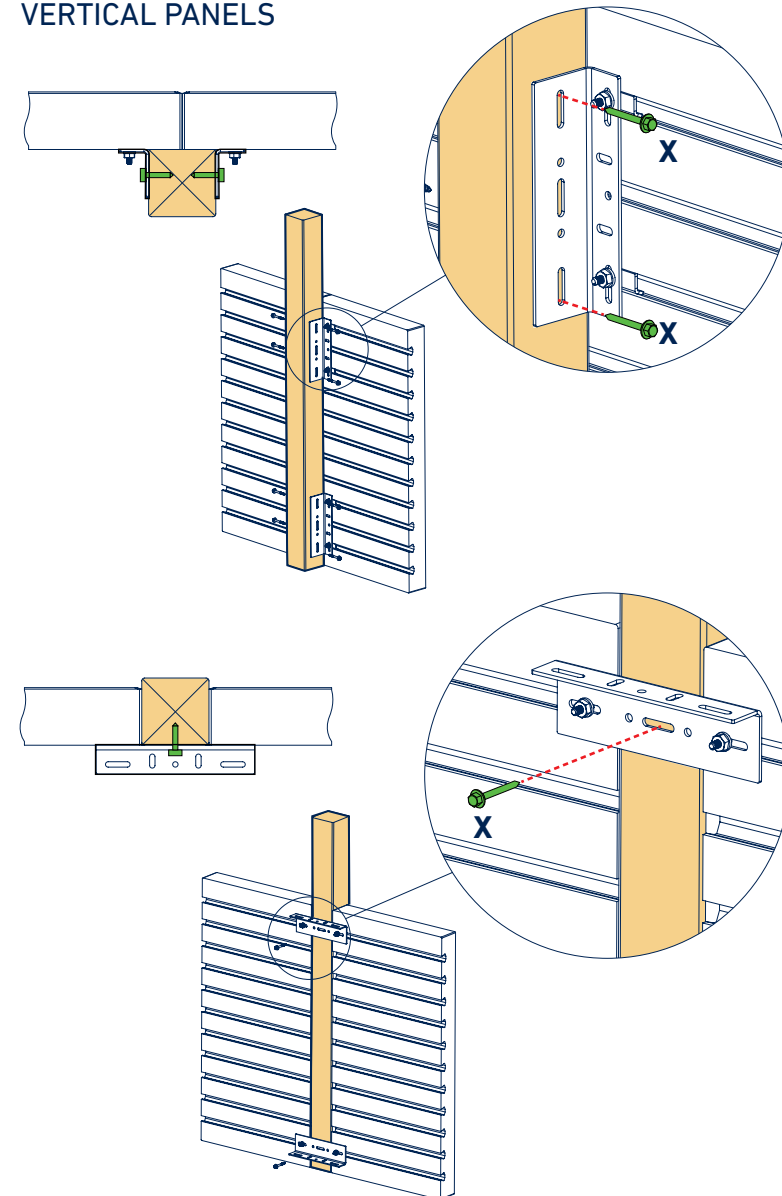

X=Stainless Steel Wood Screw Flat Head #10 x 2½"

V=Stainless Steel Lag screws 1/4 x 2½" or 5/16 x 2½"

Y=Treated Concrete Anchor (Tapcon®) 1/4"x1¾" or 3/16"x1¾" Z=Stainless Steel Oversized Washer 5/16"

**IMPORTANT:** Other types of hardware (not included) may be required to make these assemblies (wood screws, concrete anchors, etc.).

**BELGARD** is not responsible for any issue regarding other materials, accessories, other types of hardware, etc. *We recommend consulting an expert or engineer to determine the design limitations of the screen panels based on wind loads.*

## Integrating 4 x 4" Wood Posts

### HORIZONTAL PANELS

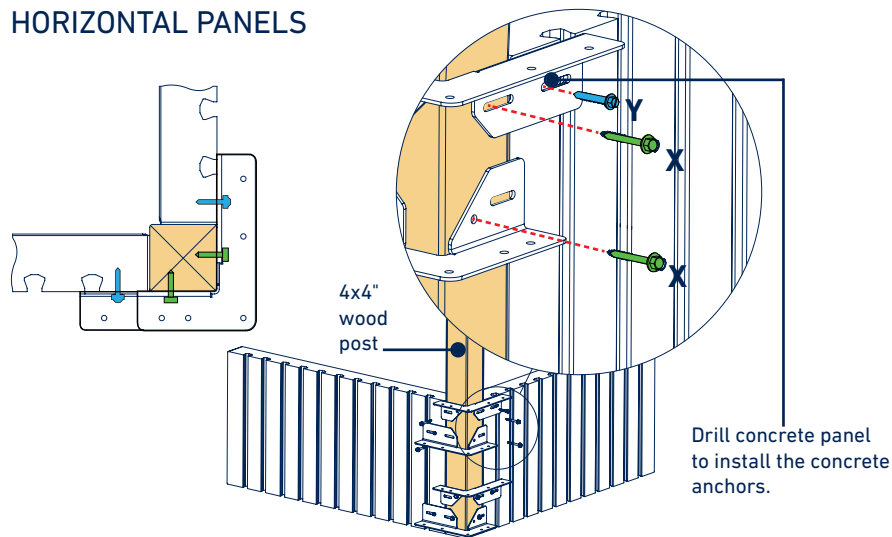

### VERTICAL PANELS

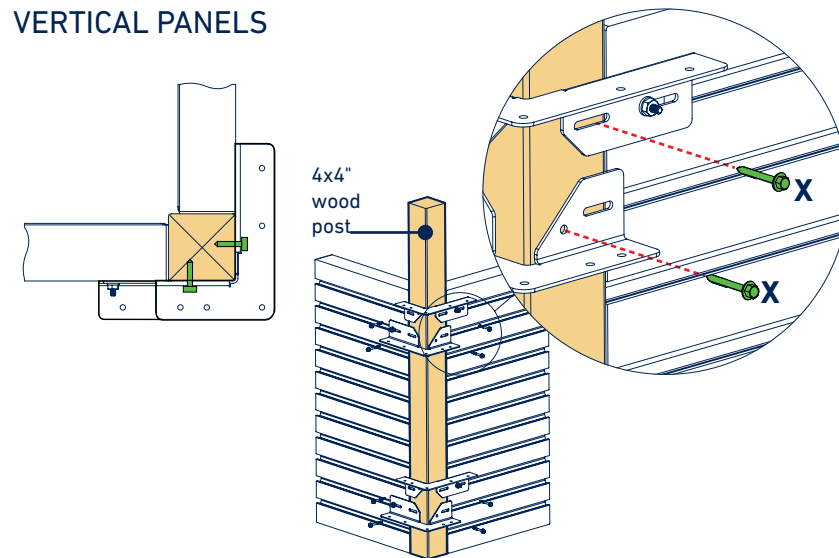

## INTEGRATING METAL POSTS

### HORIZONTAL PANELS

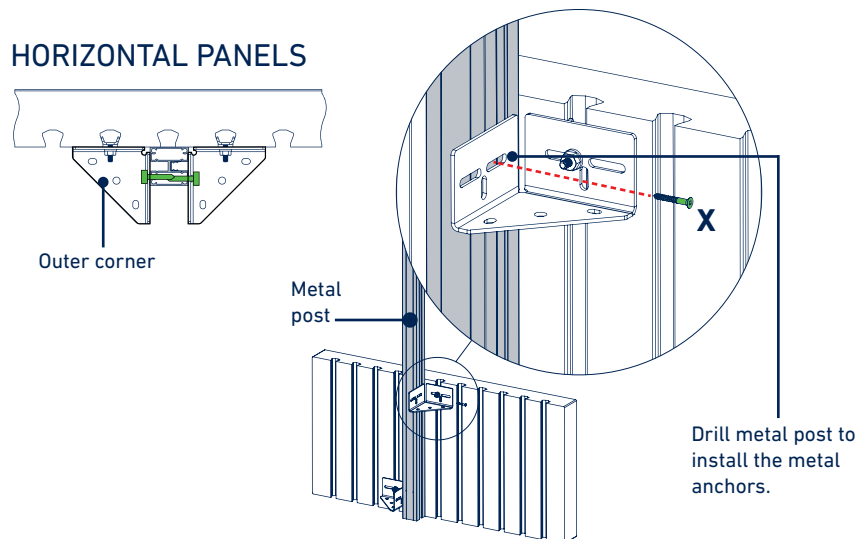

### VERTICAL PANELS

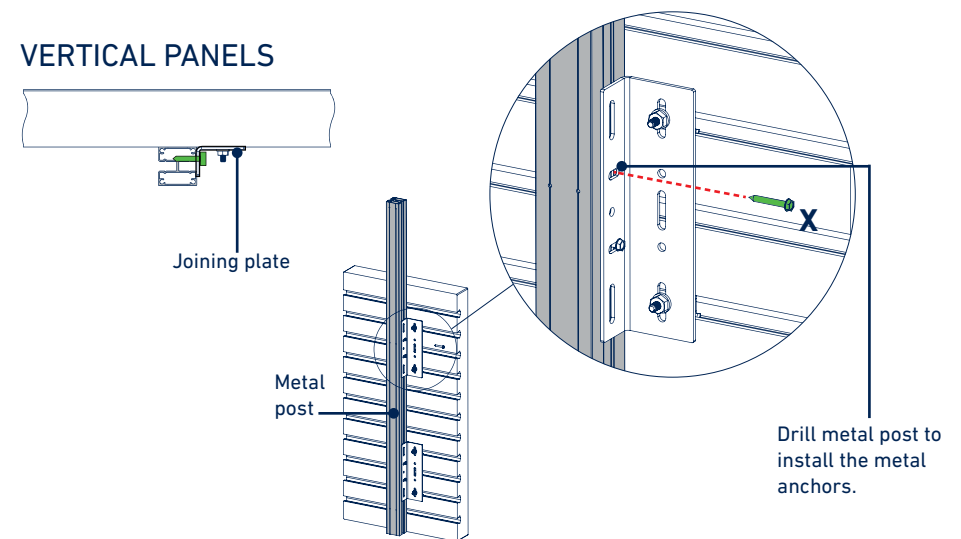

**X=Stainless Steel Wood Screw Flat Head #10 x 2½"**

**V=Stainless Steel Lag screws 1/4 x 2½" or 5/16 x 2½"**

**Y=Treated Concrete Anchor (Tapcon®) 1/4"x1¾" or 3/16"x1¾" Z=Stainless Steel Oversized Washer 5/16"**

**IMPORTANT:** Other types of hardware (not included) may be required to make these assemblies (wood screws, concrete anchors, etc.).

**BELGARD** is not responsible for any issue regarding other materials, accessories, other types of hardware, etc. *We recommend consulting an expert or engineer to determine the design limitations of the screen panels based on wind loads.*

## Base Preparation

### ON EXISTING PATIO

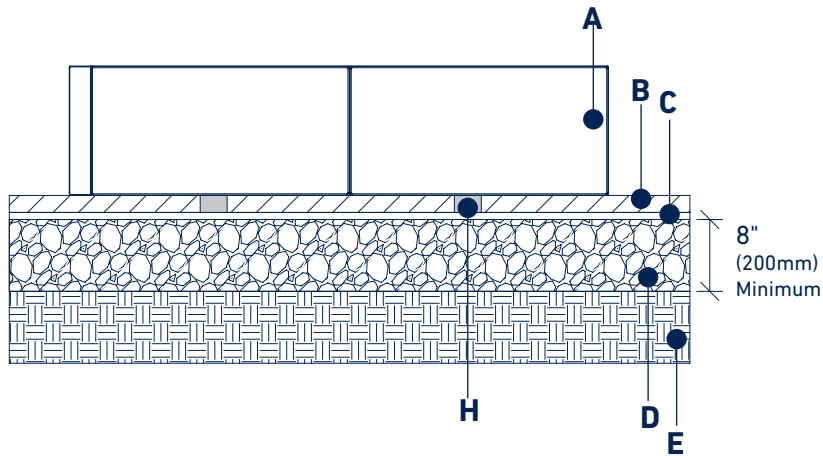

### ON COMPACTED FOUNDATION USING STARTER UNIT

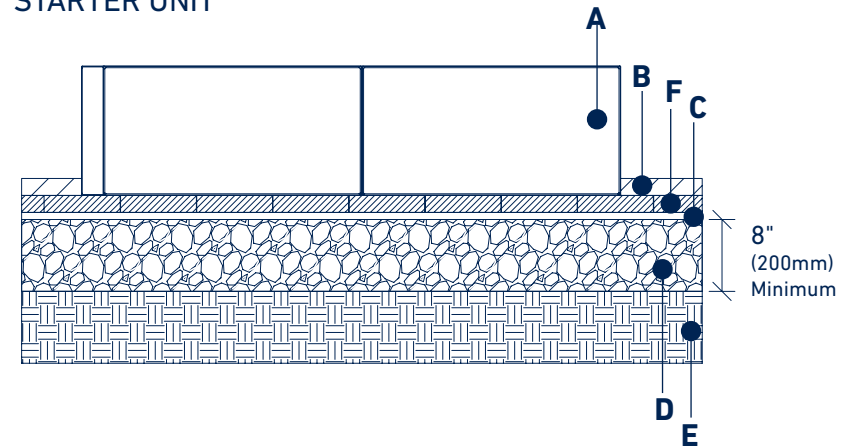

### ON POURED CONCRETE FOUNDATION

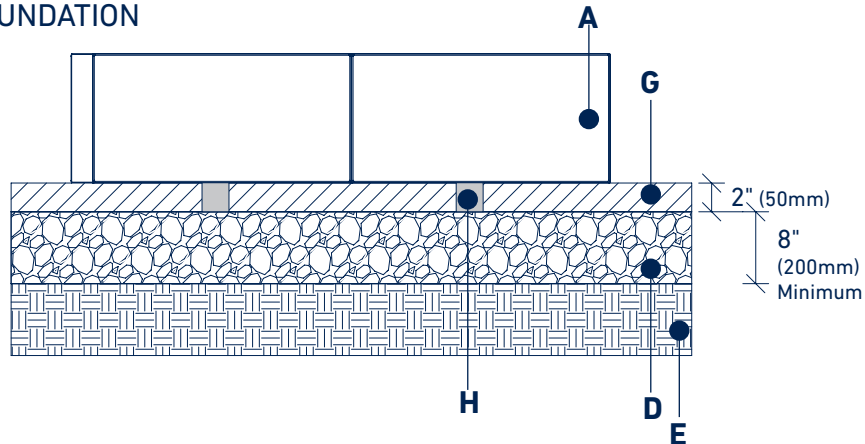

### ON COMPACTED FOUNDATION

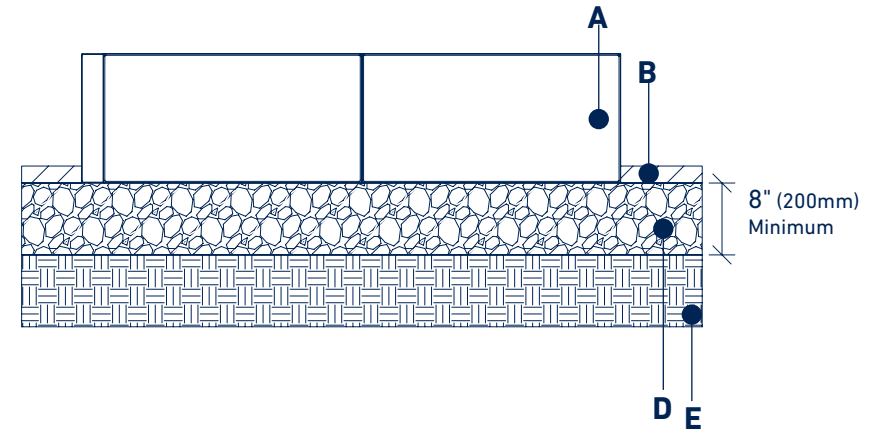

- |   |                                       |
|---|---------------------------------------|
| <b>A- ARTFORMS</b> Panels                         | <b>E- Soil</b>                        |
| <b>B- Slab or Paver</b>                           | <b>F- Starter Unit/ Slab or Paver</b> |
| <b>C- Bedding Sand 1" (25mm)</b>                  | <b>G- Reinforced Poured Concrete</b>  |
| <b>D- Compacted aggregates 8" (200mm) minimum</b> | <b>Foundation 2" (50mm) minimum</b>   |
|   | <b>H- Opening for drainage</b>        |

**IMPORTANT:** Provide adequate drainage and adjust according to soil type. Maximum height of **36"** for planter box and **42"** for outdoor living structure. Any higher structure must be designed by an engineer. Dimensions and information above are general recommendations only. Contact experts or engineers to validate the base preparation, the drainage, the plants & roots growth/management. The use of plastic shims can facilitate the installation of **Artforms** panels in order to adapt to the slope of the site.

## Planter Box Detail

ON COMPACTED FOUNDATION

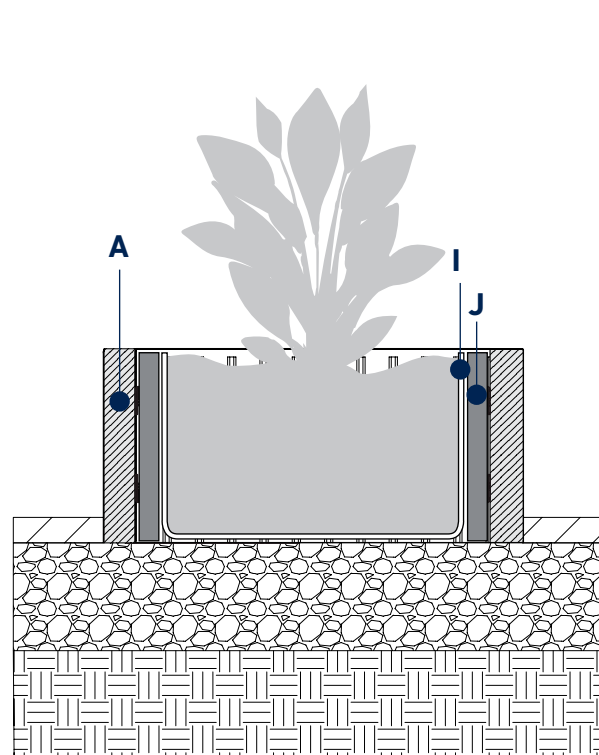
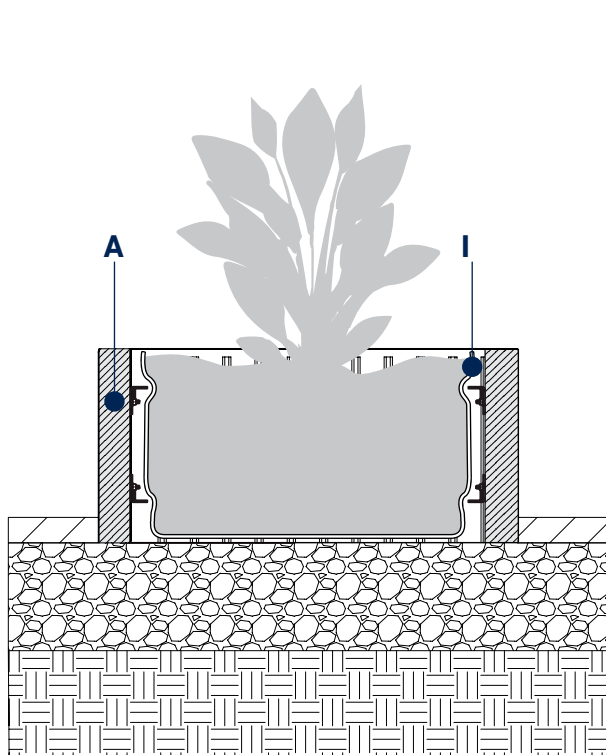

**Recommended:**  
Place insulated panels to protect plants from cold conditions.

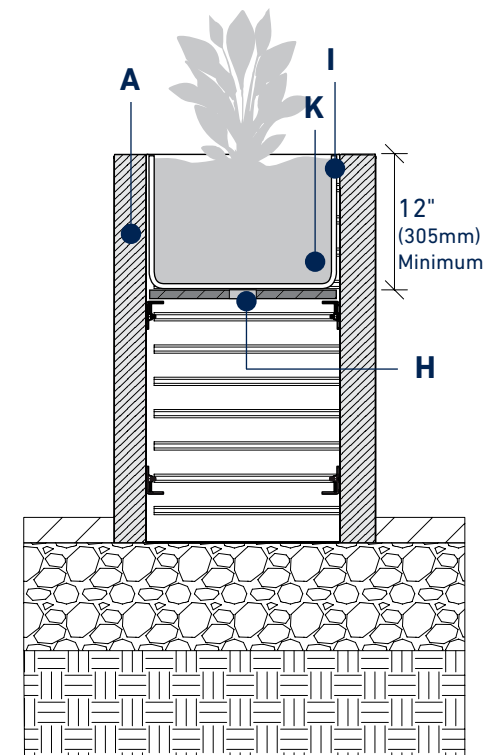

**Recommended:**  
Place a cement board on top of the Artforms hardware to reduce the amount of infill material.

**A- ARTFORMS** Panels  
**H-** Opening for drainage  
**I-** Geotextile membrane  
**J-** Insulated panel

**K-** Structural Water Resistant Panel

**IMPORTANT:** Provide adequate drainage and adjust according to soil type. Maximum height of **36"** for planter box and **42"** for outdoor living structure. Any higher structure must be designed by an engineer. Dimensions and information above are general recommendations only. Contact experts or engineers to validate the base preparation, the drainage, the plants & roots growth/management. The use of plastic shims can facilitate the installation of **Artforms** panels in order to adapt to the slope of the site.

# Rooftop Applications

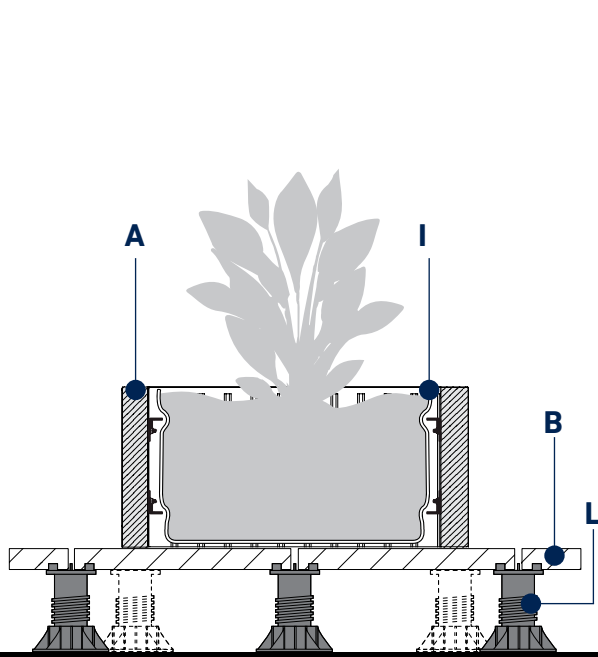

PLANTER BOX WITH HORIZONTAL  
PANELS SITTING ON SLABS/TILES - SECTION VIEW

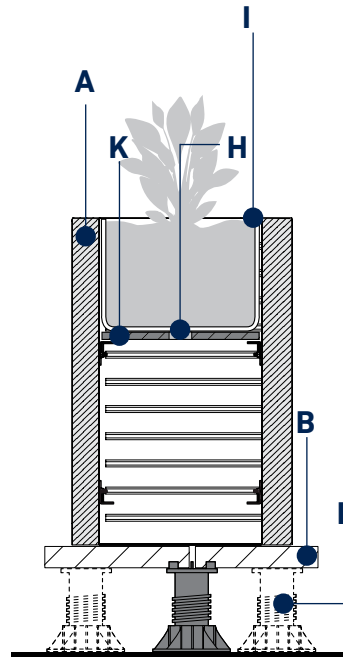

PLANTER BOX WITH VERTICAL  
PANELS SITTING ON SLABS/TILES  
- SECTION VIEW

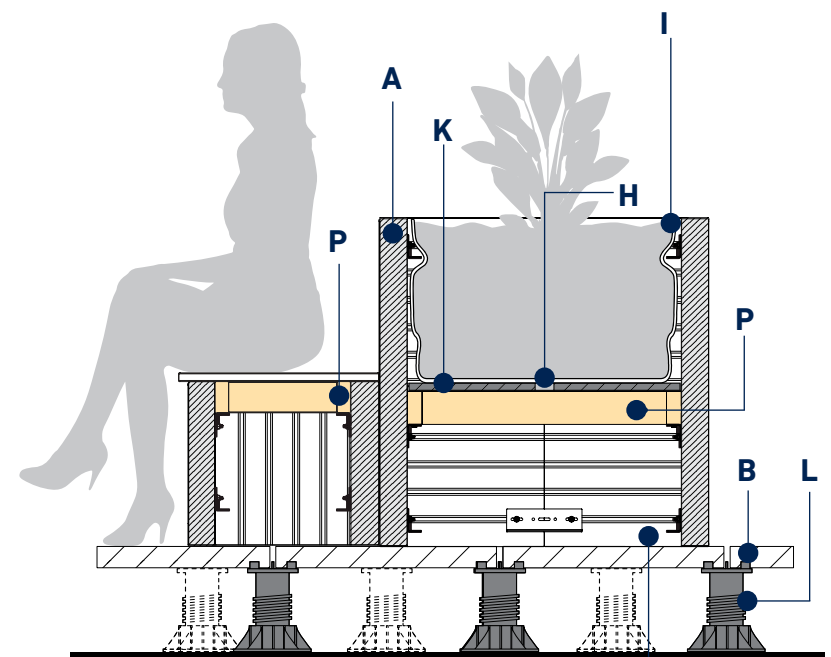

PLANTER BOX AND BENCH SITTING ON SLABS/TILES  
- SECTION VIEW

- A- ARTFORMS** Panels
- B-** Slab or Tile
- H-** Opening for drainage
- I -** Geotextile Membrane
- K-** Structural Water Resistant Panel
- L-** Pedestal
- P-** Treated Wood Structure

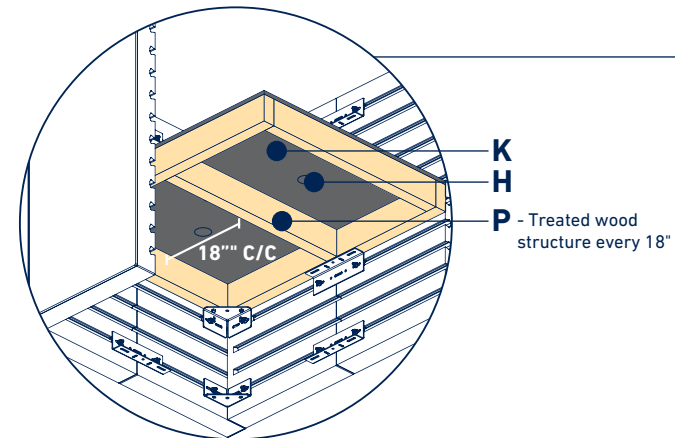

**IMPORTANT:** Contact experts or engineers for proper staging on existing rooftop surfaces.

# Rooftop Applications

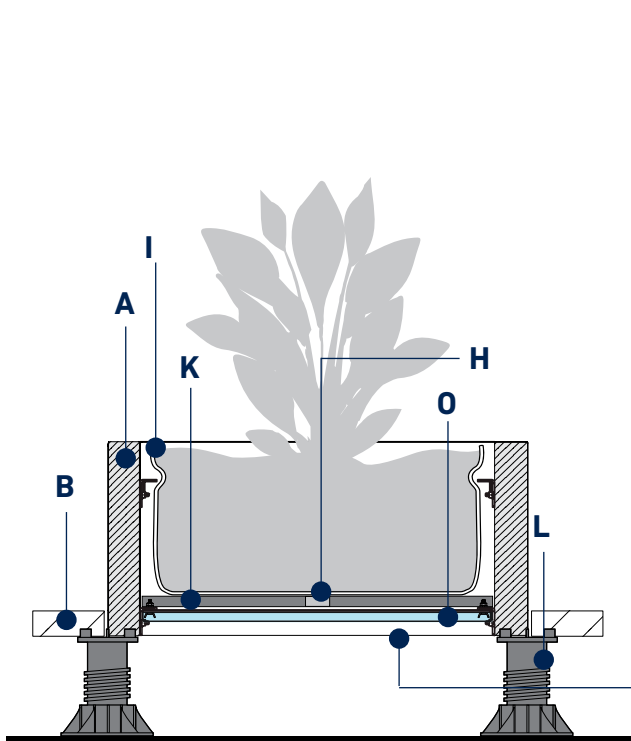

PLANTER BOX SITTING ON PEDESTALS - SECTION VIEW

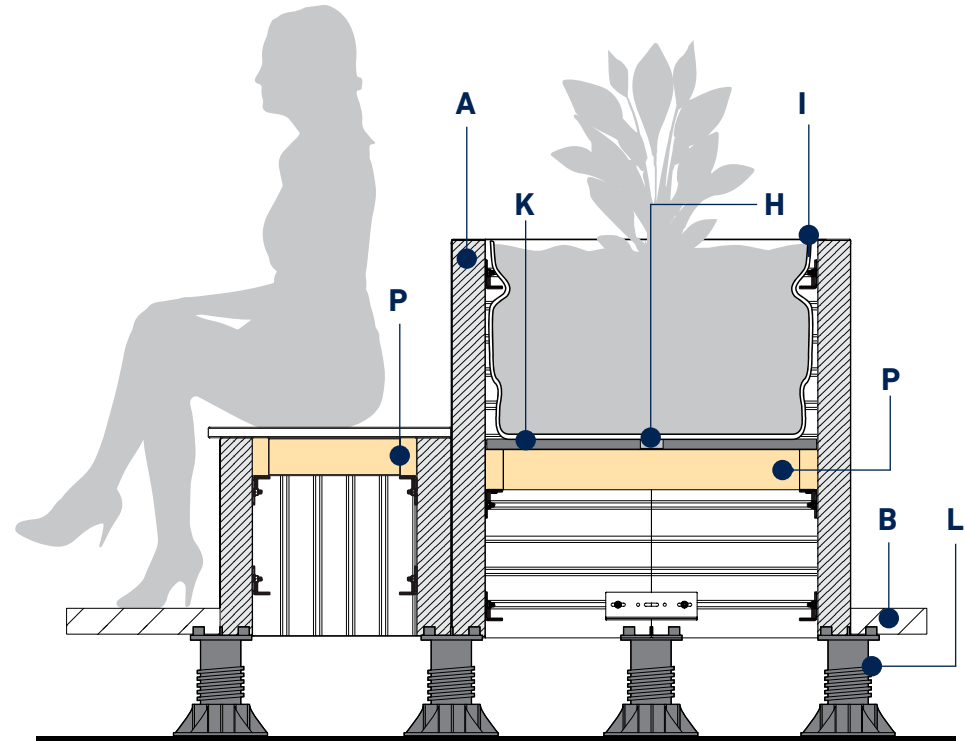

BENCH AND PLANTER BOX SITTING ON PEDESTALS - SECTION VIEW

- A- ARTFORMS** Panels
- B- Slab or Tile**
- H- Opening for drainage**
- I - Geotextile Membrane**
- K- Structural Water Resistant Panel**
- L- Pedestal**
- O- Stretcher bar**
- P- Treated Wood Structure**

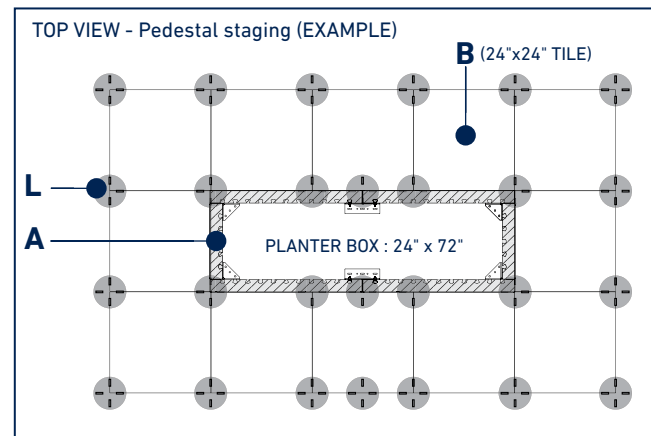
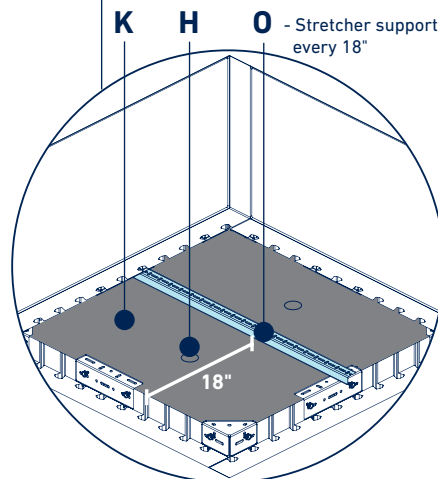

**IMPORTANT:** Contact experts or engineers for proper staging on existing rooftop surfaces.

# Handling

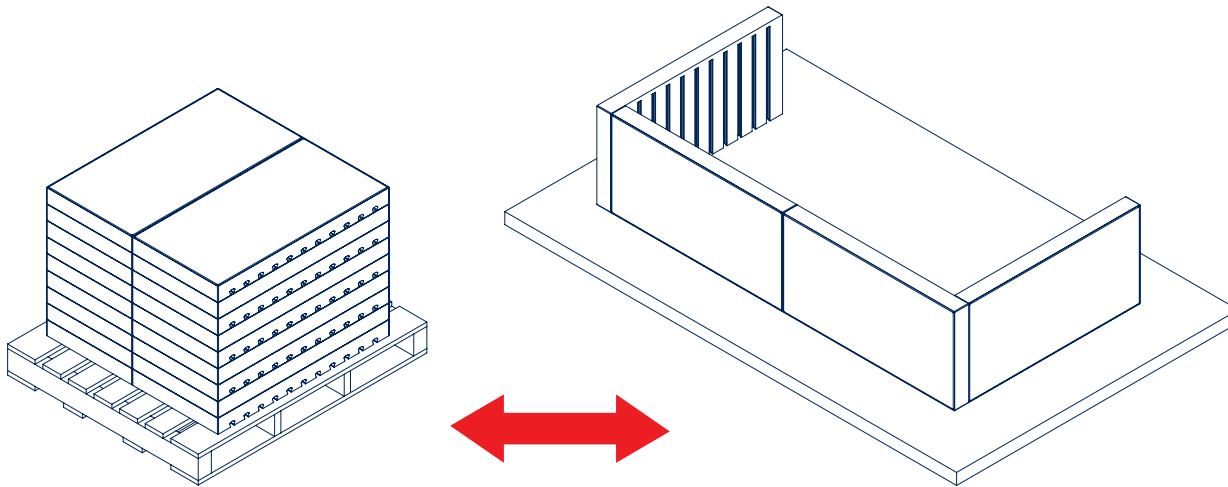

Place pallet close to installation area

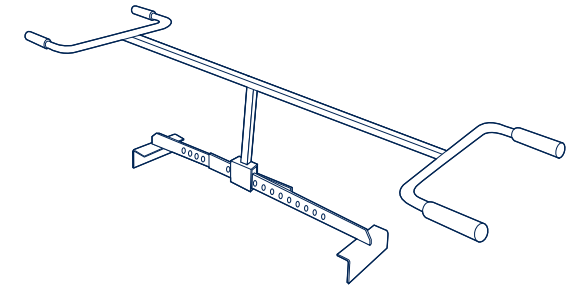

Recommended handling tool

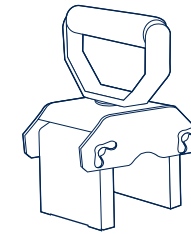

Recommended handling tool

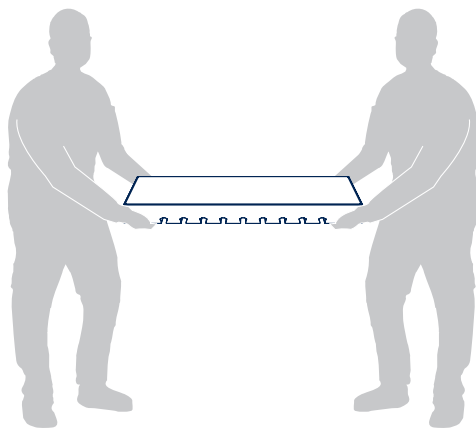

Lift with two people

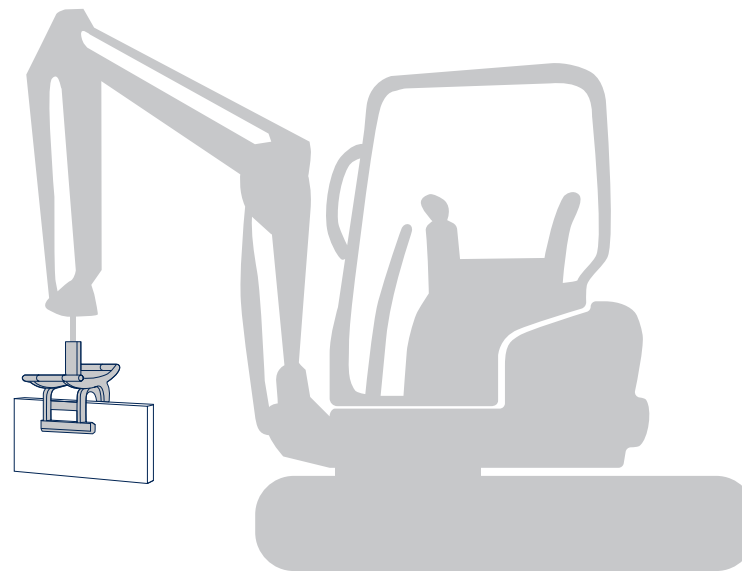

Mechanical lifting device



Use hand trolley if necessary

## Tips and Tricks

**#1** [General]: Ensure that all the panels are in place, leveled & aligned before fully tightening the hardware in the corners at the end of the installation.

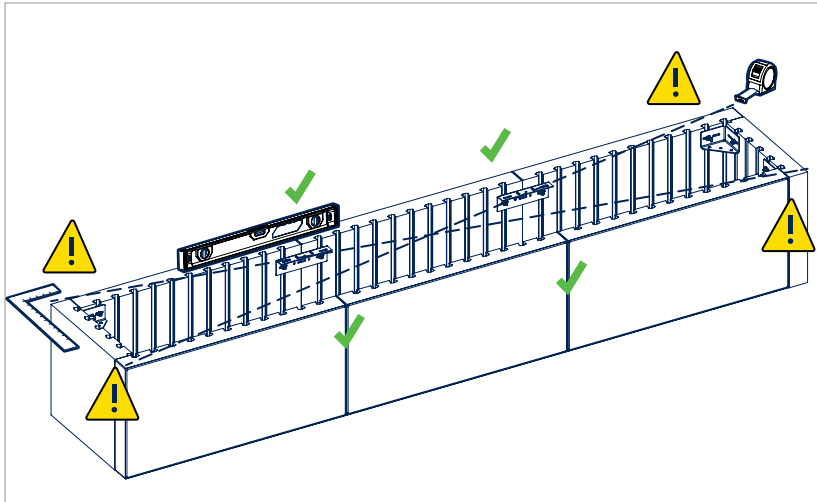

**#2** [General]: Pre-assemble hardware to facilitate its installation. Ensure that all the panels are in place, leveled & aligned before fully tighten the hardware at the end of the installation.

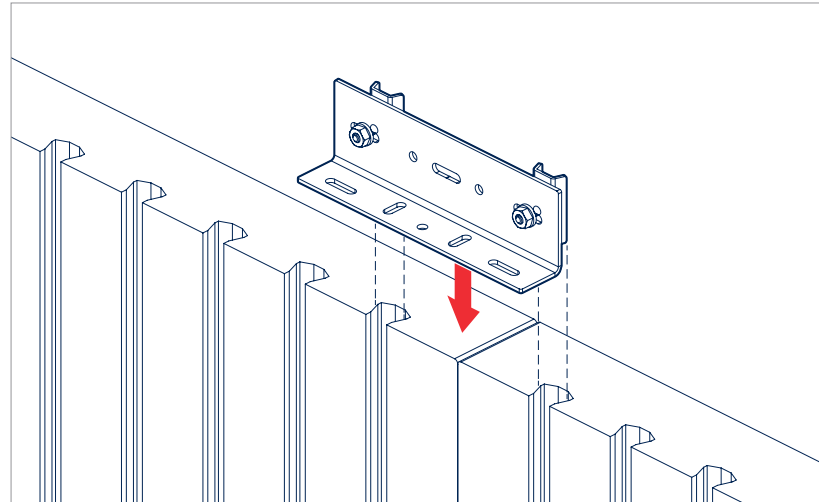

**#3** [Anchor slide]: Insert anchor slides from the bottom of the closed end panel (panel A) prior to its assembly.

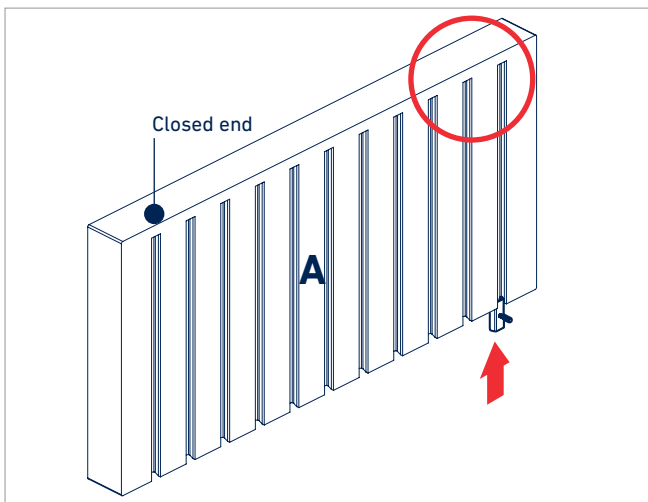

**#4** [Anchor slide]: Insert the anchor slide. Lock it into place to prevent it from sliding down and to facilitate assembly.

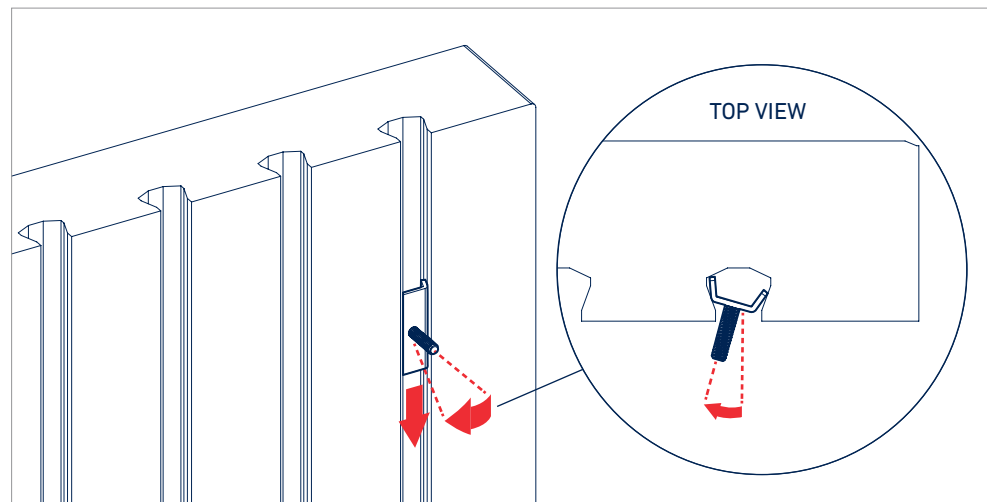

## Tips and Tricks

**#5** [Joining plate]: Use the larger tab of the joining plate when it is perpendicular or parallel to the dovetail slot.

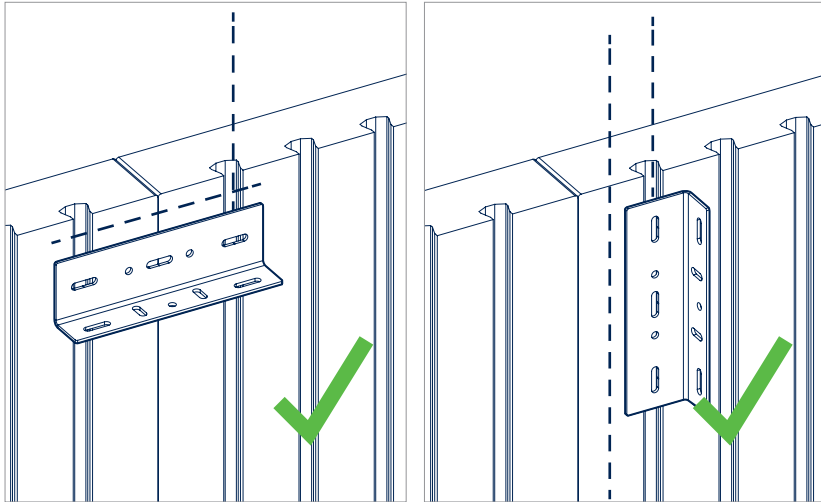

**#6** [Joining plate]: Only when the joining plate is perpendicular to the dovetail, the small tab can be used. Otherwise, the overlapping surface will be too narrow.

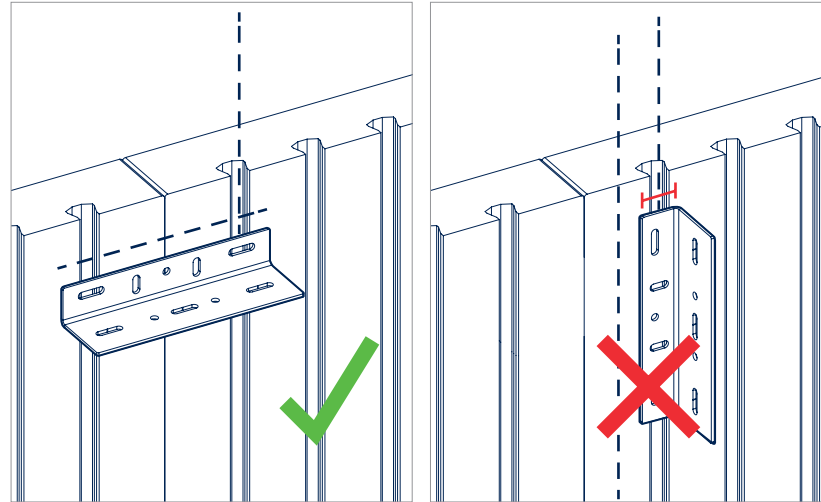

**#7** [Stretcher bar]: Use the stretcher bar when it is perpendicular to the dovetail. Otherwise, the overlapping surface will be too narrow.

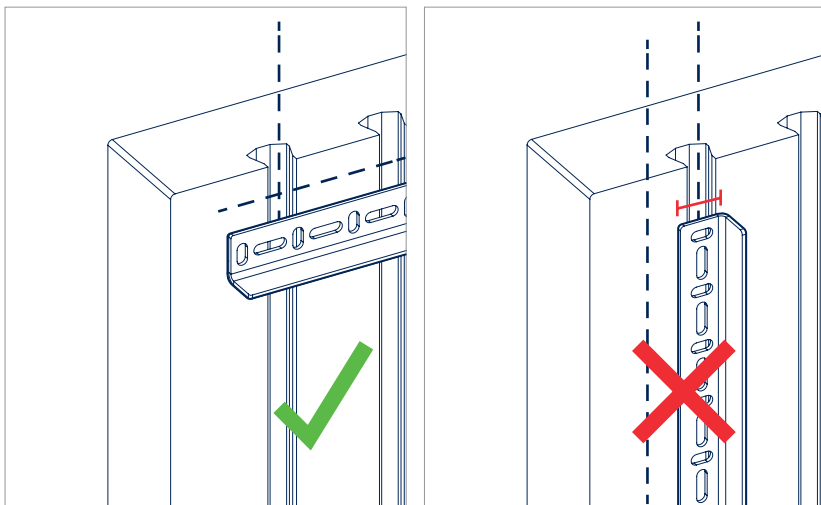

**#8** [Bar Clamp]: Use the bar clamp to keep the panels in place and to facilitate the hardware installation.

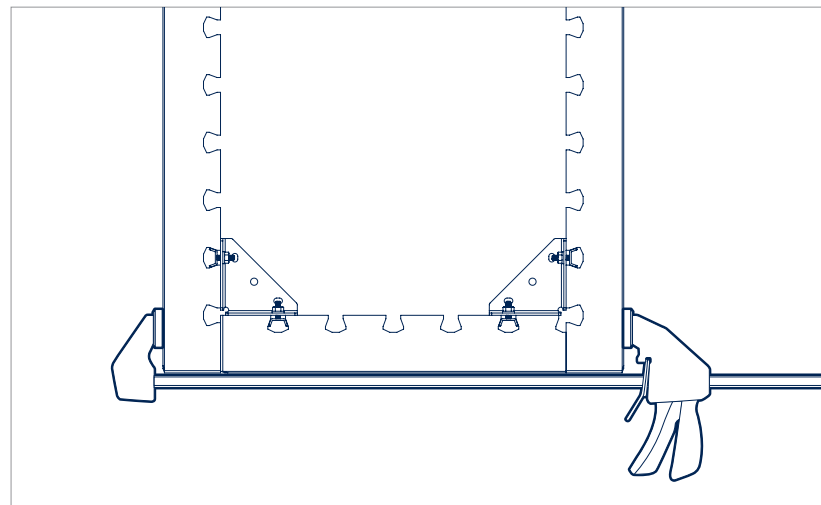

## Tips and Tricks

**#9** [General]: If required, it is possible to secure the **ARTFORMS** structure to the existing base by placing the hardware against it. Contact experts/engineers to validate the structure and any related matters.

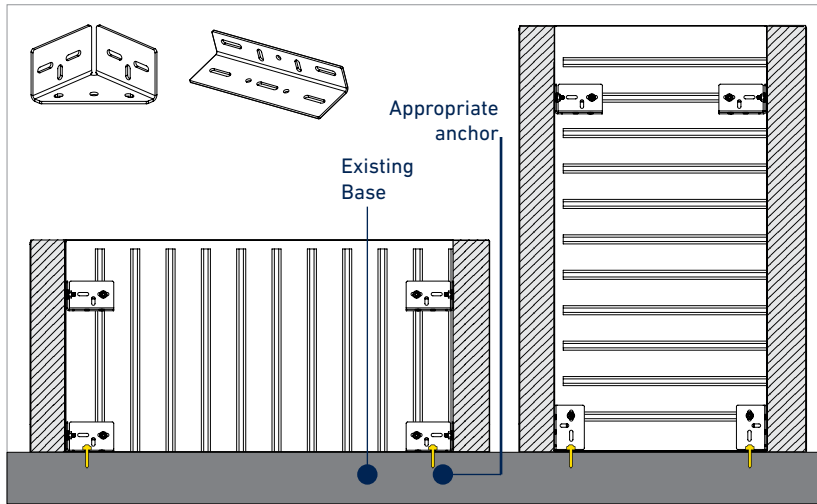

**#11** [General]: In the case you forgot to place the anchor slides when the closed end panels (panel A) have already been assembled, use a chipping hammer to break a small section of the dovetail slot to insert the anchor slide.

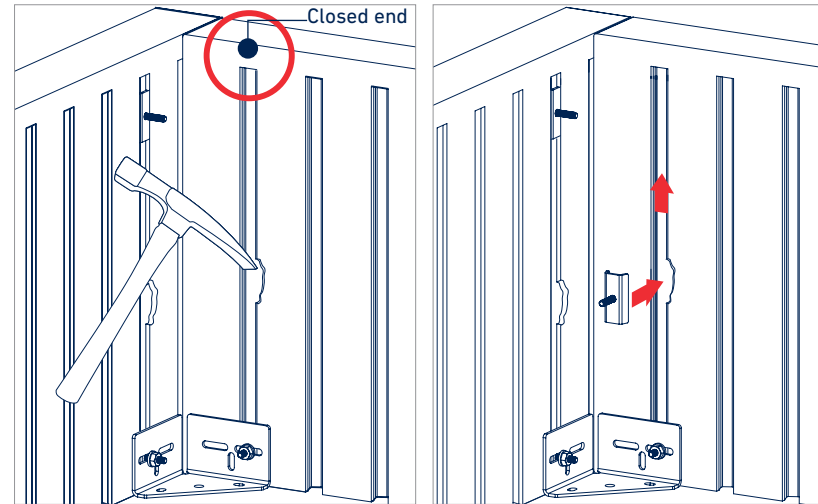

**#10** [General]: If the side to side panels have a different thickness, use plastic shims to align the front face.

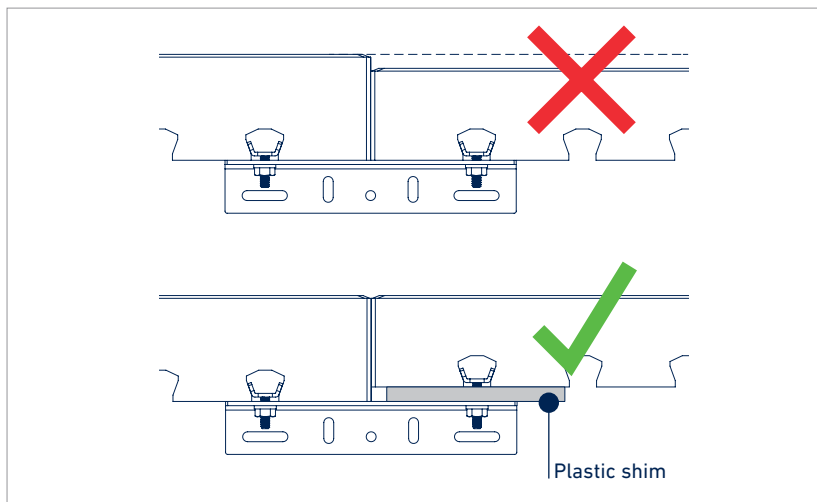

**#12** [General]: If assembling the hardware on the side of the panel without dovetails, drill the panel and use a concrete screw anchor (Tapcon®).

**NOTE** : Y: Concrete screw anchor (Tapcon®) ¼" x 1¾" or ⅜" x 1¾"

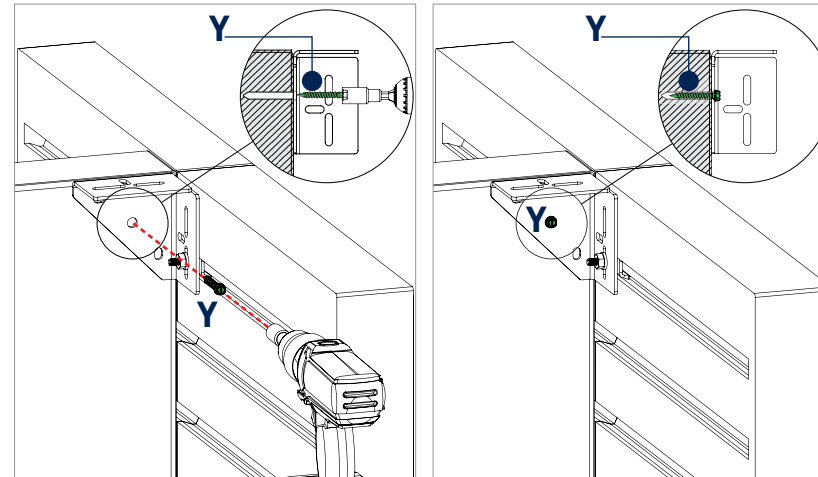

## Tips and Tricks

**#13** [Custom angle]: In case of an **OUTER OBTUSE ANGLE CORNER** (more than 90°) cut the both panels to the appropriate/needed angle. Use construction glue or Techniseal® Structure Bond™ to solidify the corners.

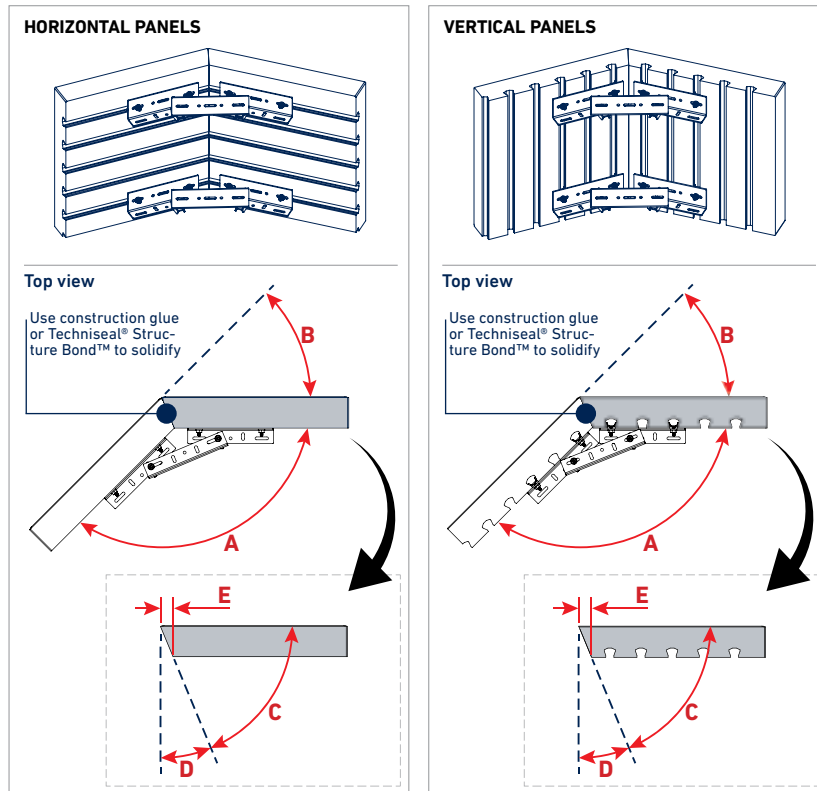

**#14** [Custom angle]: In case of an **INNER OBTUSE ANGLE CORNER** (more than 90°) cut the both panels to the appropriate/needed angle. Use construction glue or Techniseal® Structure Bond™ to solidify the corners.

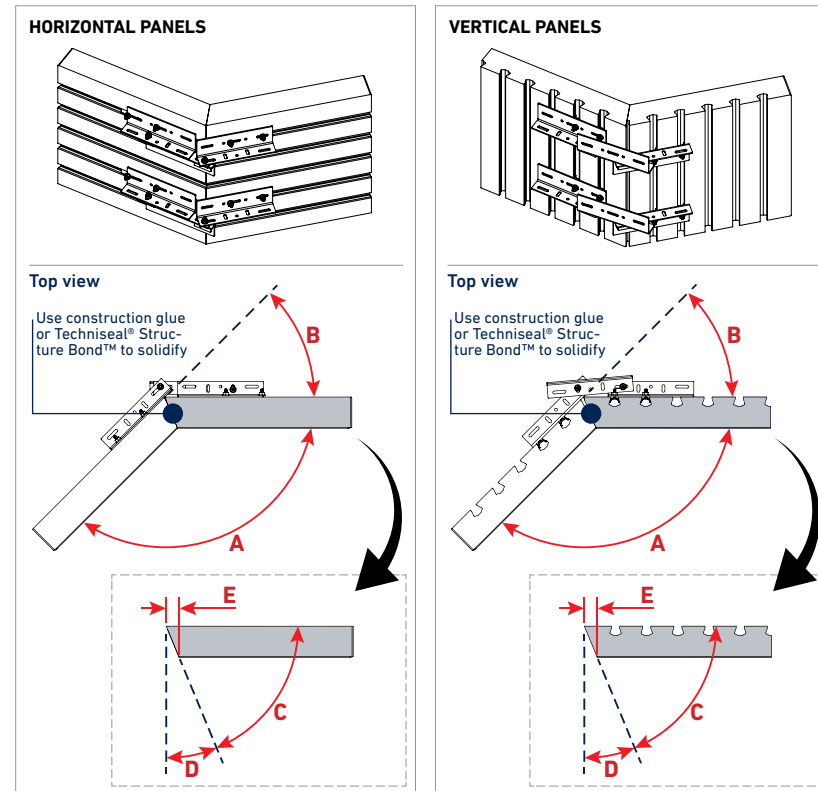

**OUTER OBTUSE ANGLE CORNER**

A	B	C	D	E
100 °	80 °	50 °	50 °	2.5" (63 mm)
110 °	70 °	55 °	55 °	2" (50 mm)
120 °	60 °	60 °	60 °	1.7" (42 mm)
130 °	50 °	65 °	65 °	1.35" (35 mm)
140 °	40 °	70 °	70 °	1" (25 mm)
150 °	30 °	75 °	75 °	0.8" (20 mm)
160 °	20 °	80 °	80 °	0.5" (15 mm)
170 °	10 °	85 °	85 °	0.25" (7 mm)

**INNER OBTUSE ANGLE CORNER**

A	B	C	D	E
100 °	80 °	50 °	50 °	2.5" (63 mm)
110 °	70 °	55 °	55 °	2" (50 mm)
120 °	60 °	60 °	60 °	1.7" (42 mm)
130 °	50 °	65 °	65 °	1.35" (35 mm)
140 °	40 °	70 °	70 °	1" (25 mm)
150 °	30 °	75 °	75 °	0.8" (20 mm)
160 °	20 °	80 °	80 °	0.5" (15 mm)
170 °	10 °	85 °	85 °	0.25" (7 mm)

# Tips and Tricks

**#15** [Custom angle]: In case of an **OUTER ACUTE ANGLE CORNER** (less than 90°) cut just one panel to the appropriate/needed angle. Use construction glue or Techniseal® Structure Bond™ to solidify the corners.

**#16** [Custom angle]: In case of an **INNER ACUTE ANGLE CORNER** (less than 90°) cut just one panel to the appropriate/needed angle. Use construction glue or Techniseal® Structure Bond™ to solidify the corners.

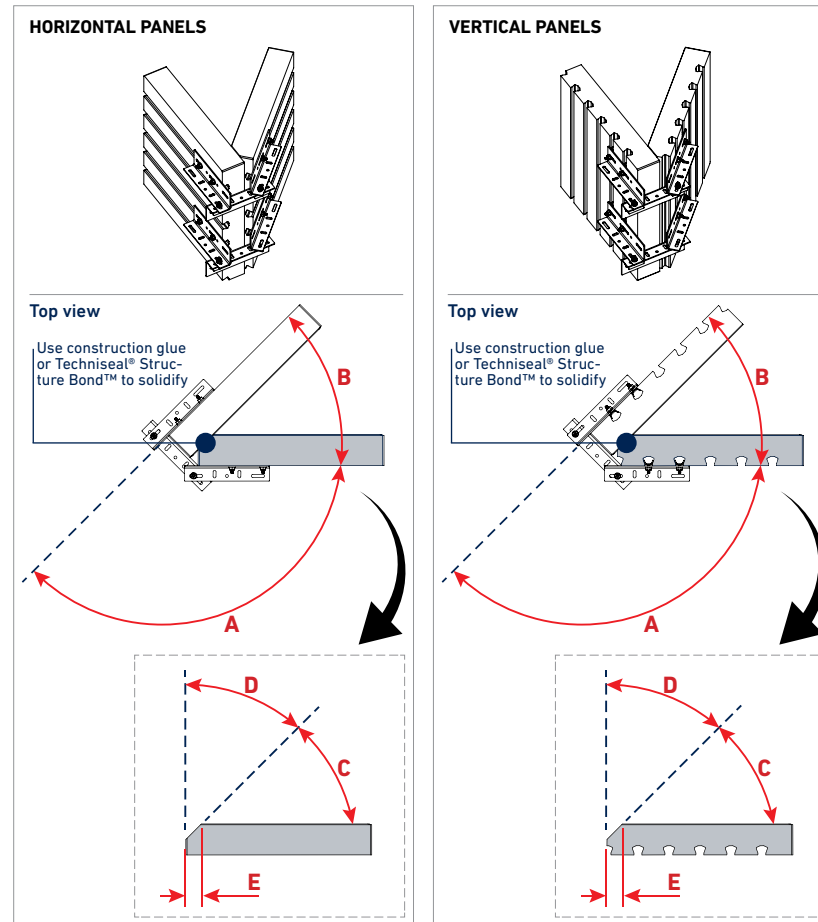
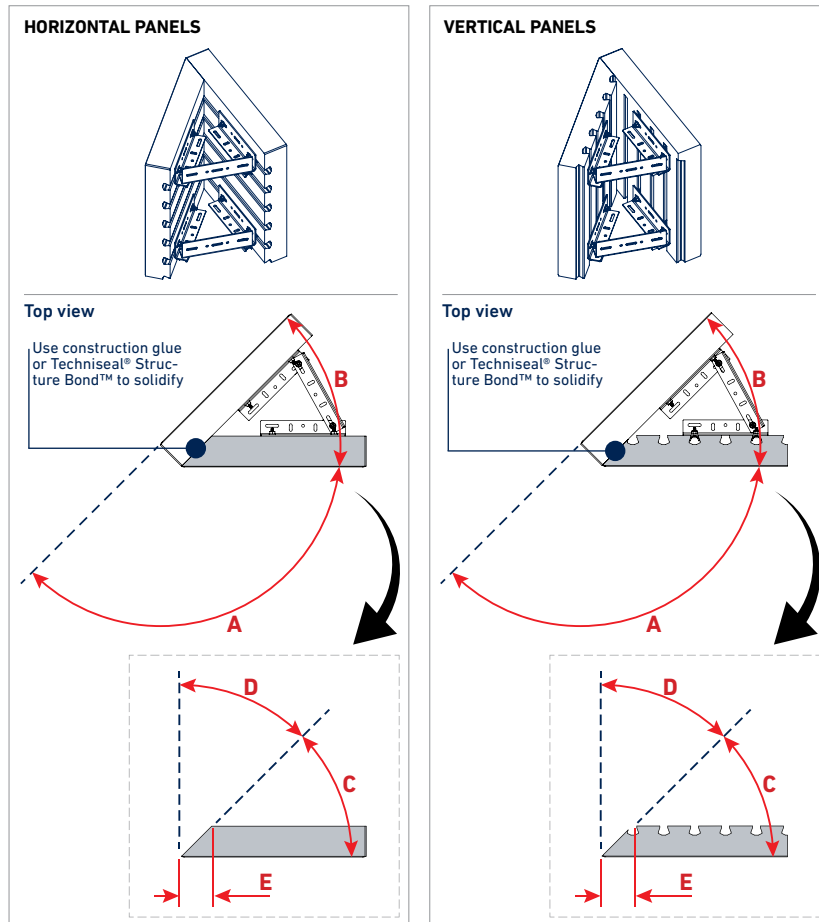

**OUTER ACUTE ANGLE CORNER**

A	B	C	D	E
135 °	45 °	45 °	45 °	2.9" (75 mm)
125 °	55 °	55 °	35 °	2" (50 mm)
115 °	65 °	65 °	25 °	1.3" (35 mm)
105 °	75 °	75 °	15 °	0.8" (20 mm)

**INNER ACUTE ANGLE CORNER**

A	B	C	D	E
135 °	45 °	45 °	45 °	2.9" (75 mm)
125 °	55 °	55 °	35 °	2" (50 mm)
115 °	65 °	65 °	25 °	1.3" (35 mm)
105 °	75 °	75 °	15 °	0.8" (20 mm)

**BELGARD®**

AN OLDCASTLE® APG OUTDOOR BRAND

**BELGARD.COM**

© 2026 Oldcastle® APG, Inc. All Rights Reserved. BEL26-D-705550 | Revised 05/2026

