



DESIGNFORMS™



**SEATING COMBO C -
1 VERTICAL PLANTER UNIT & 1 6FT BENCH UNIT**



DESIGNFORMS™

**SEATING COMBO C -
1 VERTICAL PLANTER UNIT & 1 6FT BENCH UNIT**

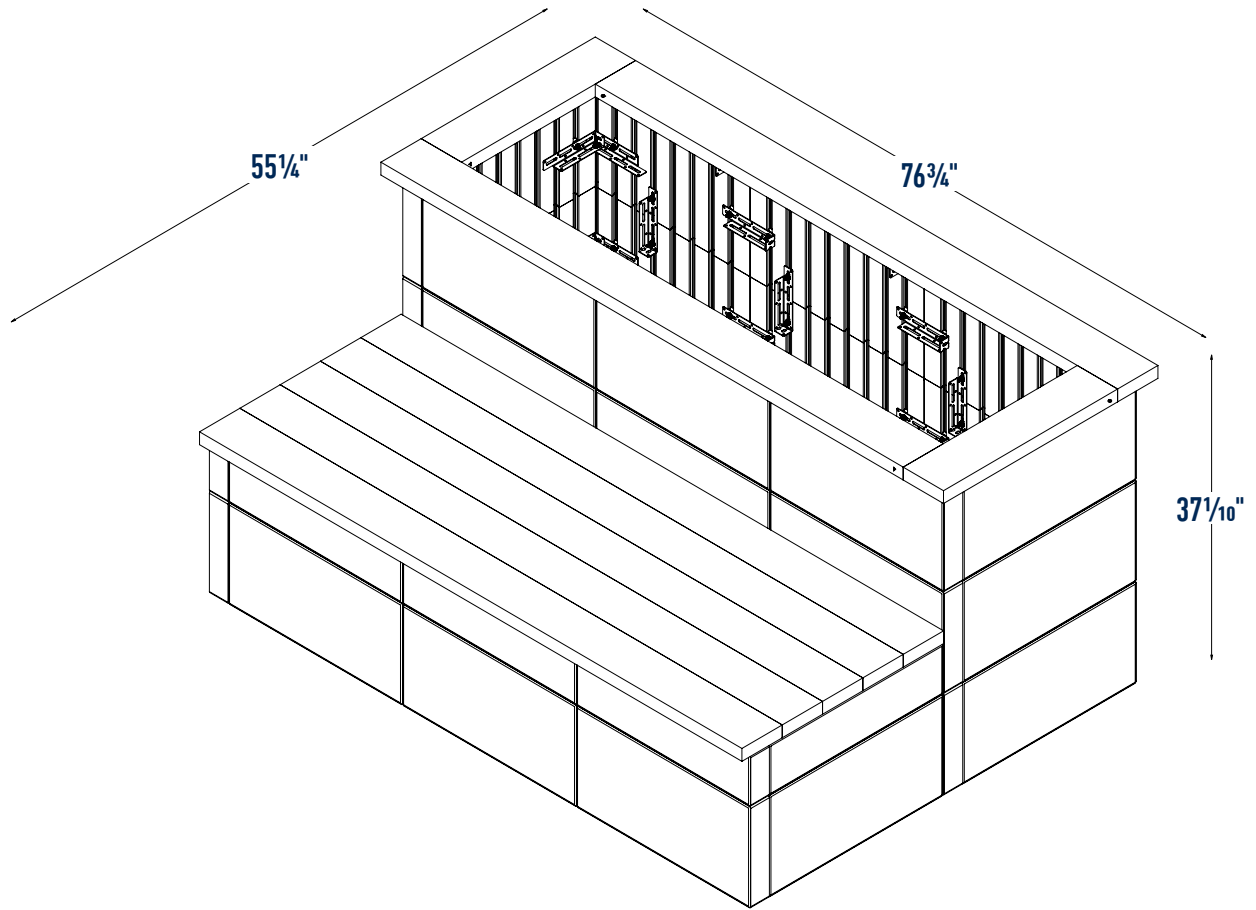

COMPONENTS

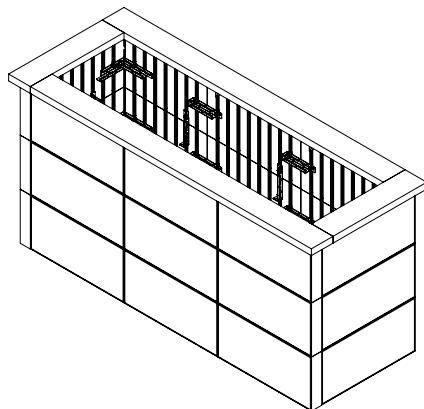

**3FT Vertical Planter
- Wood Top (x1)**

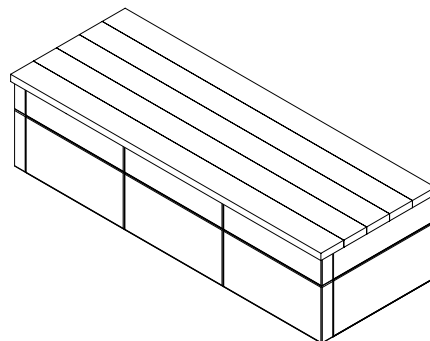

**6FT Bench
- Wood Top (x1)**

REQUIRED TOOLS

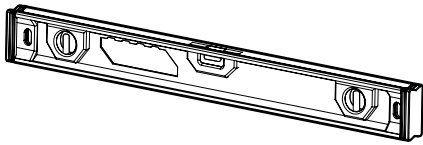

LEVEL

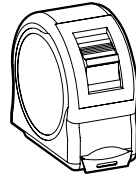

MEASURING TAPE

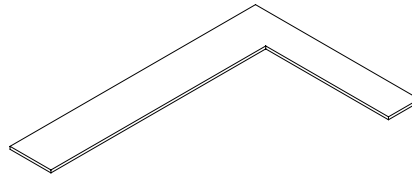

CARPENTER SQUARE

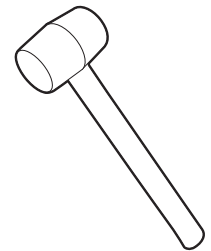

RUBBER MALLET

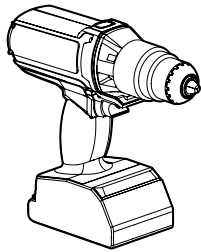

DRILL



**DEEP HEX SOCKET
7/16" WITH 1/4" DRIVE**

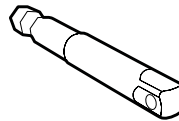

**SOCKET ADAPTOR
1/4" HEX SHANK TO 1/4" DRIVE**

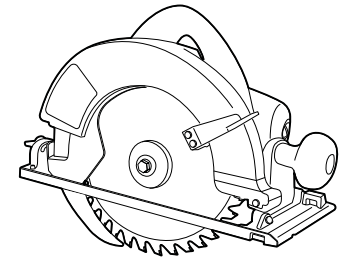

SKILL SAW

SAFETY EQUIPMENT



SAFETY BOOTS

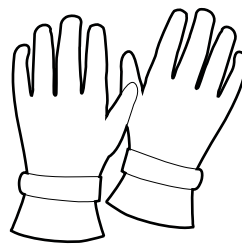

GLOVES

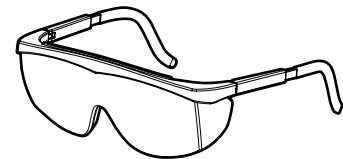

SAFETY GLASSES

BASE PREPARATION

ALWAYS LEVEL GROUND BEFORE INSTALLATION

ON NEW OR EXISTING PATIO

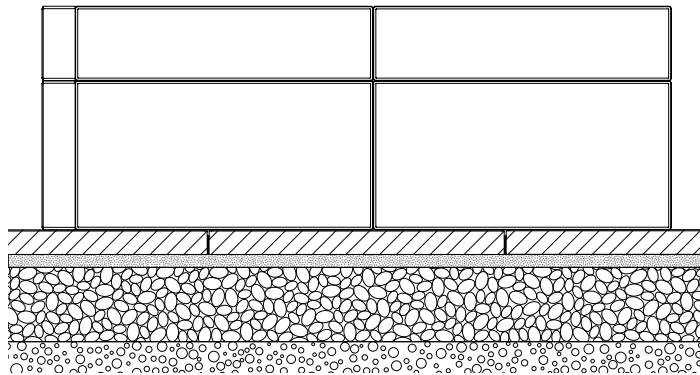

SLAB OR PAVER



BEDDING SAND 1"



COMPACTED AGGREGATES 6" - 8"



SOIL

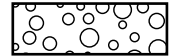

ON POURED CONCRETE

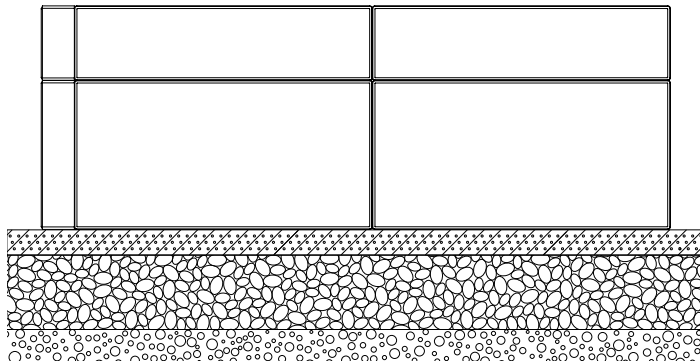

REINFORCED POURED CONCRETE FOUNDATION 2"

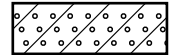

COMPACTED AGGREGATES 6" - 8"



SOIL

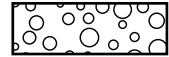

ON COMPACTED FOUNDATION

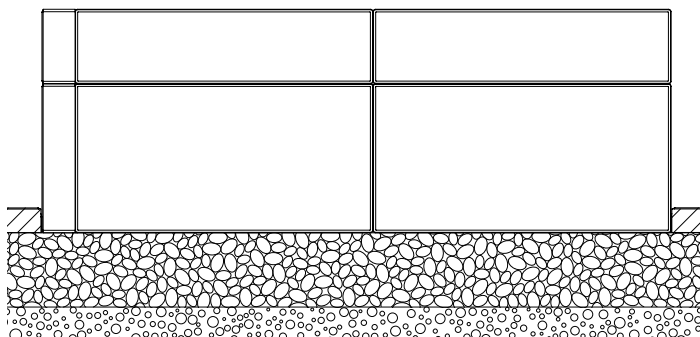

SLAB OR PAVER



COMPACTED AGGREGATES 6" - 8"



SOIL

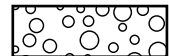

TIPS & TRICKS

READ ALL INSTRUCTIONS BEFORE ASSEMBLY

PREBUILD:

- Prebuild all hardware prior to starting build.
- When assembling hardware SNAP the bolt into place with the plastic sliders. Pressing down on something flat and hard will help. (Fig. A)
- Do not over hand tighten the slider/bolt piece and the nut on the completed brackets. They should be loosely attached so they slide into the channels on the panels. Leave a space of ¼ in. (Fig. B)

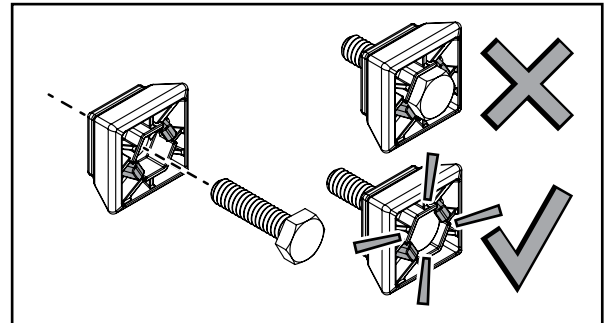

Fig. A

INSTALL:

- Always start in the corner when starting a build. (Fig. C)
- Set the drill clutch (torque) at a low level to deliver a torque range of 50-65lbs per inch. Refer to your drill manual for torque adjustment instructions.
- Use a rubber mallet to assist with moving/aligning/adjusting panel placement during assembly.

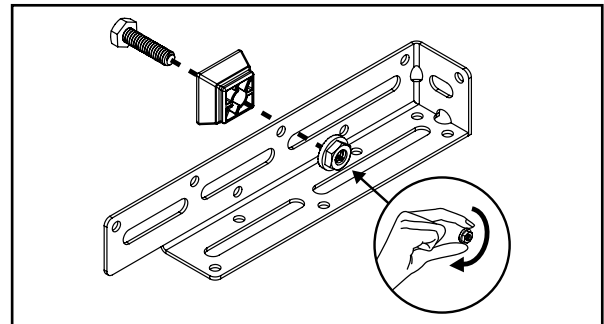

Fig. B

WHEN BUILDING WOODEN COMPONENTS:

- Do not exceed prescribed length. Exact measurements are required for proper assembly.
- Ensure your cuts are straight.
- Do not over tighten the screws into the wood - this can cause buckling.
- Pre-drill holes for 45° corner assemblies.
- Use cedar or pressure treated wood for outdoor use.
- Seal wooden components for prolonged use.

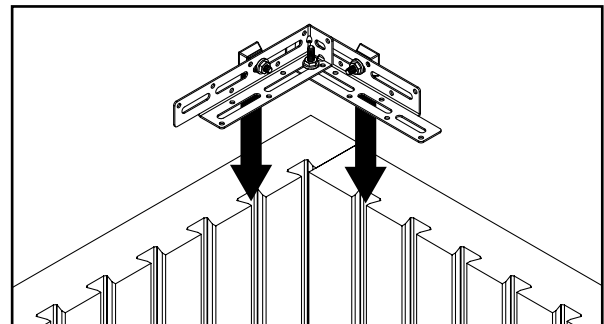
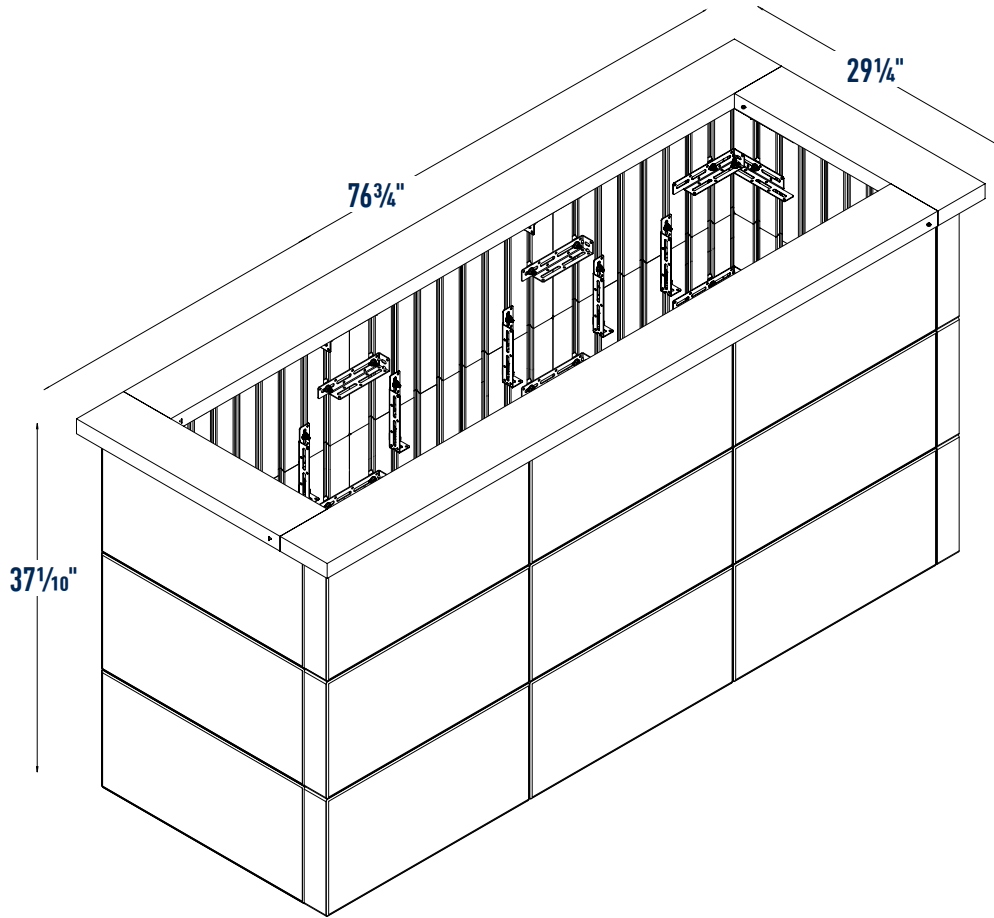

Fig. C

WHEN BUILDING PLANTERS:

- Line the inside of the planters or garden beds with a geotextile fabric to help with water management.



COMPONENTS

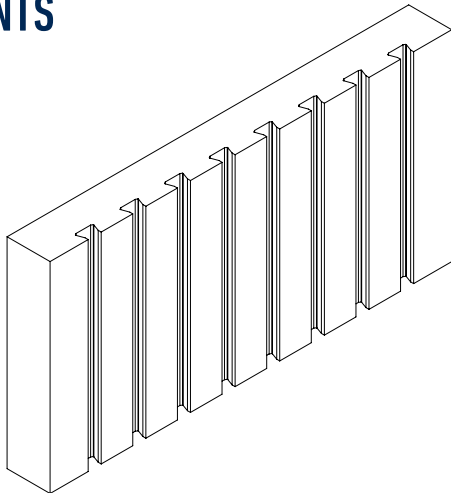

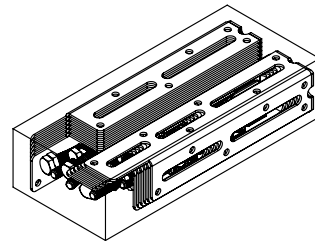

Large Panel (x24)
12" x 24"



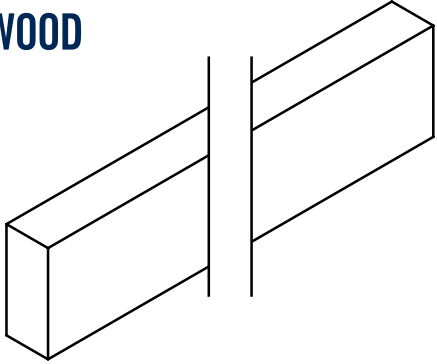
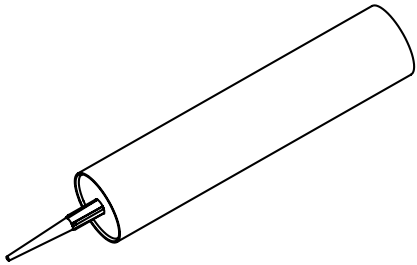
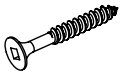

Hardware Kit (x6)

ADDITIONAL WOOD CAP COMPONENTS

<p>2" x 6" x 8' PRESSURE TREATED WOOD</p> 	x2	<p>OUTDOOR SILICONE</p> 	x1	<p>A #8 1 1/4" DECK SCREW</p> 	x16
				<p>B #8 3" DECK SCREW</p> 	x8

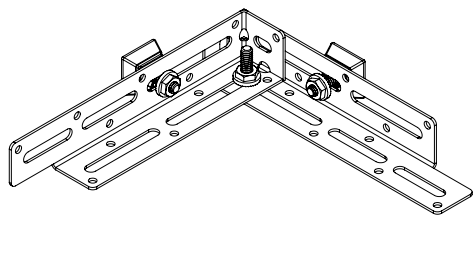
WOOD CUTS			1 = 71 1/4" 2 = 23 3/4"
1	2		
1	2		

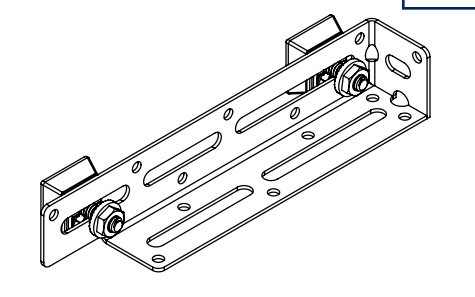
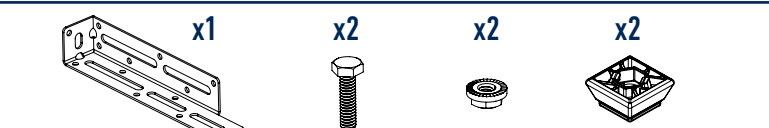
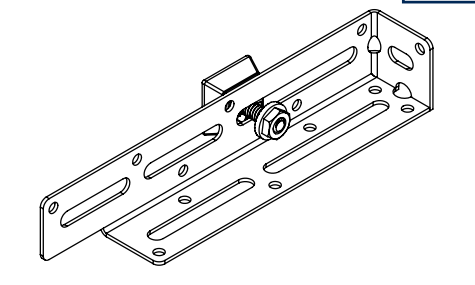
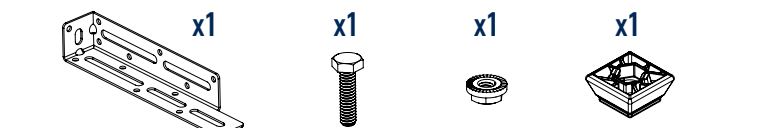
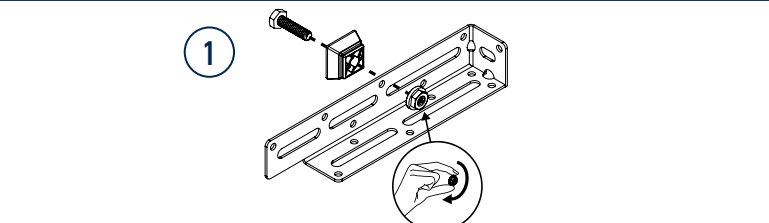
<p>BRACKET A</p> <p>x12</p> 	<p>x2 x3 x1 x3 x2</p> 
<p>BRACKET C</p> <p>x44</p> 	<p>x1 x2 x2 x2</p> 
<p>BRACKET D</p> <p>x4</p> 	<p>x1 x1 x1 x1</p> 
<p>1</p> 	



1

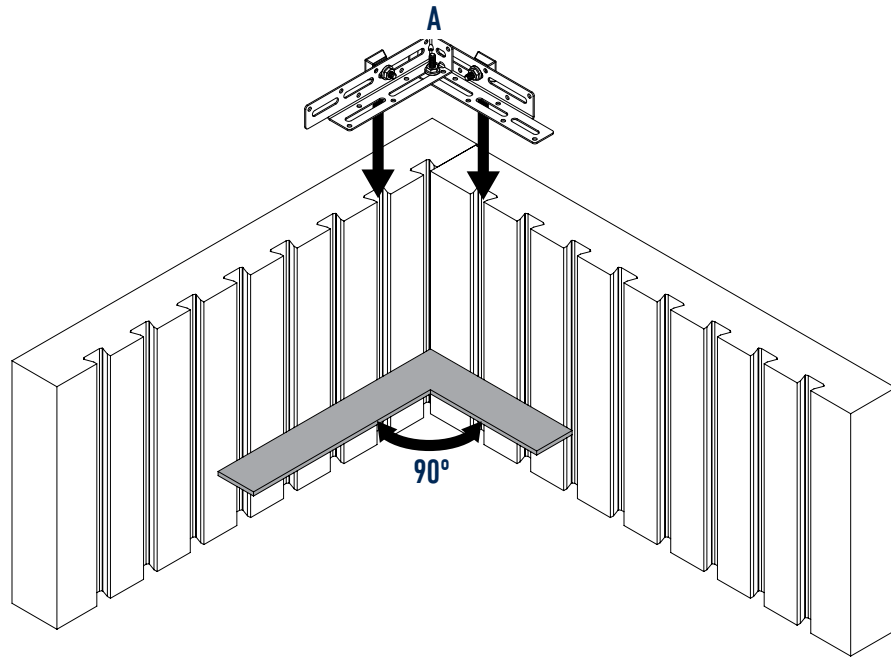

2

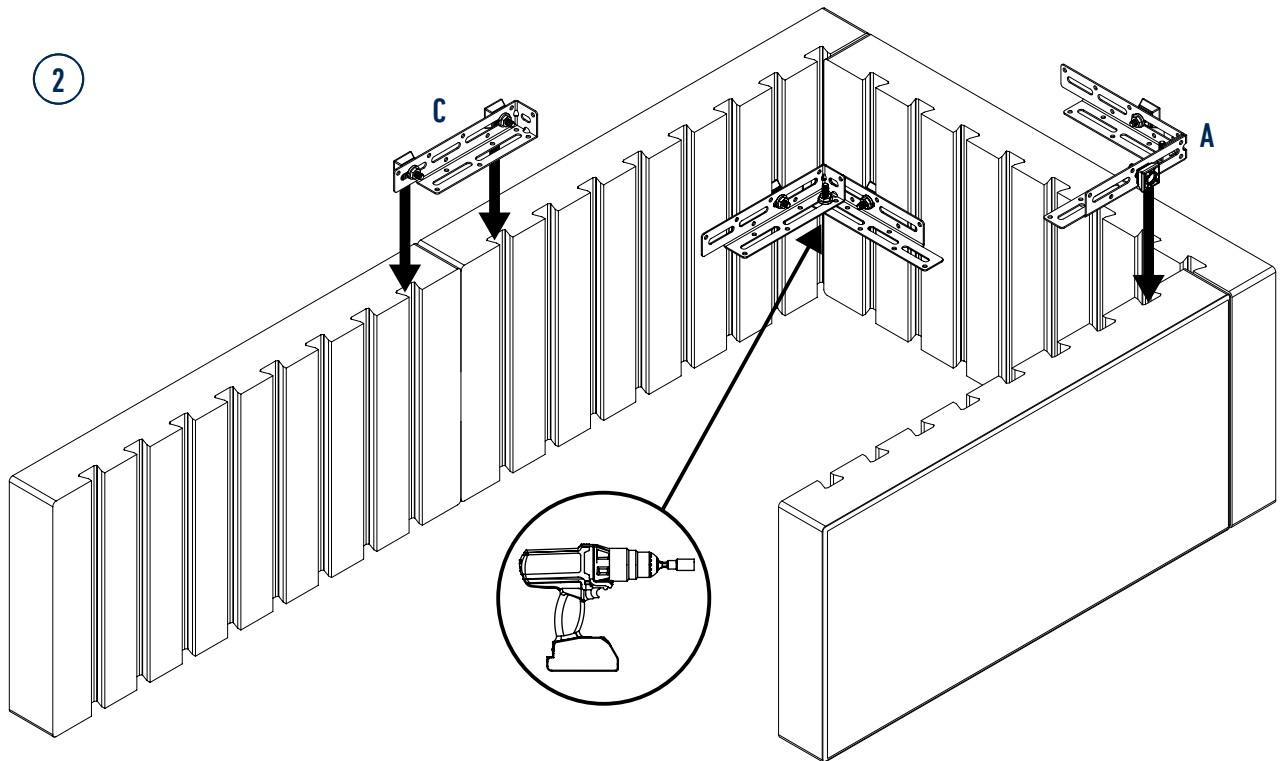



3

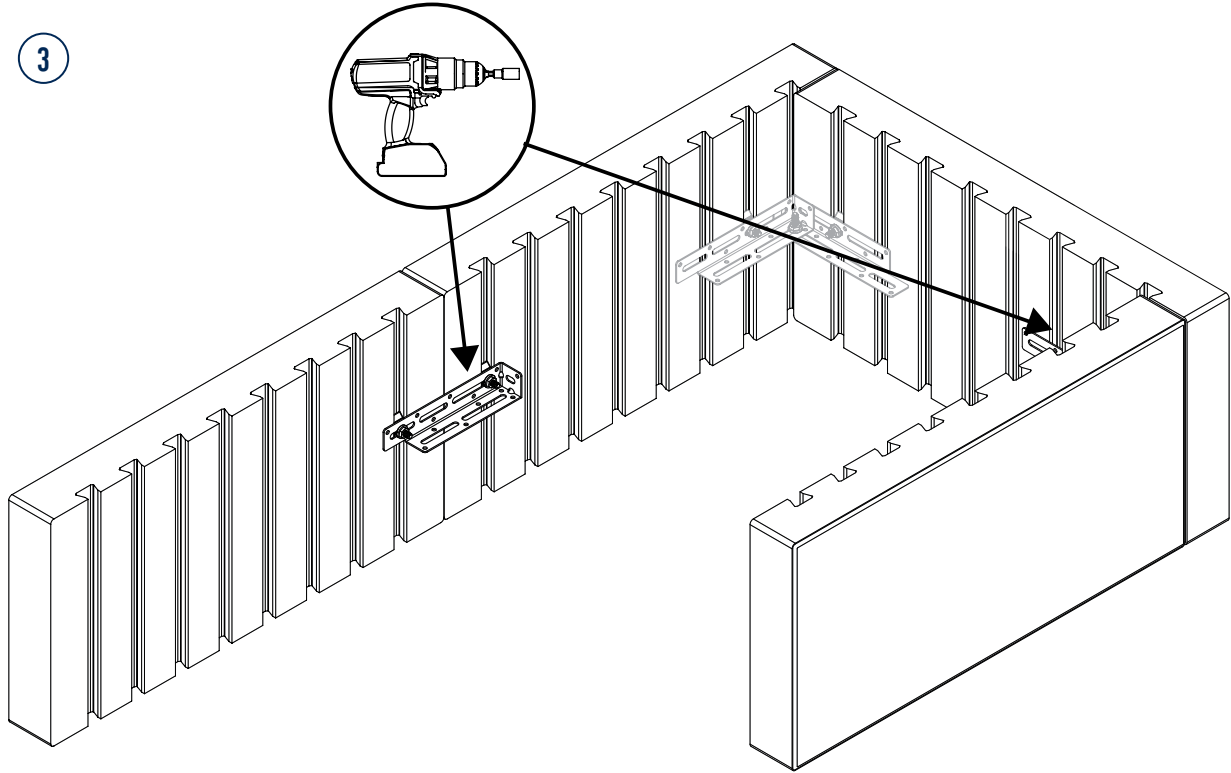

4

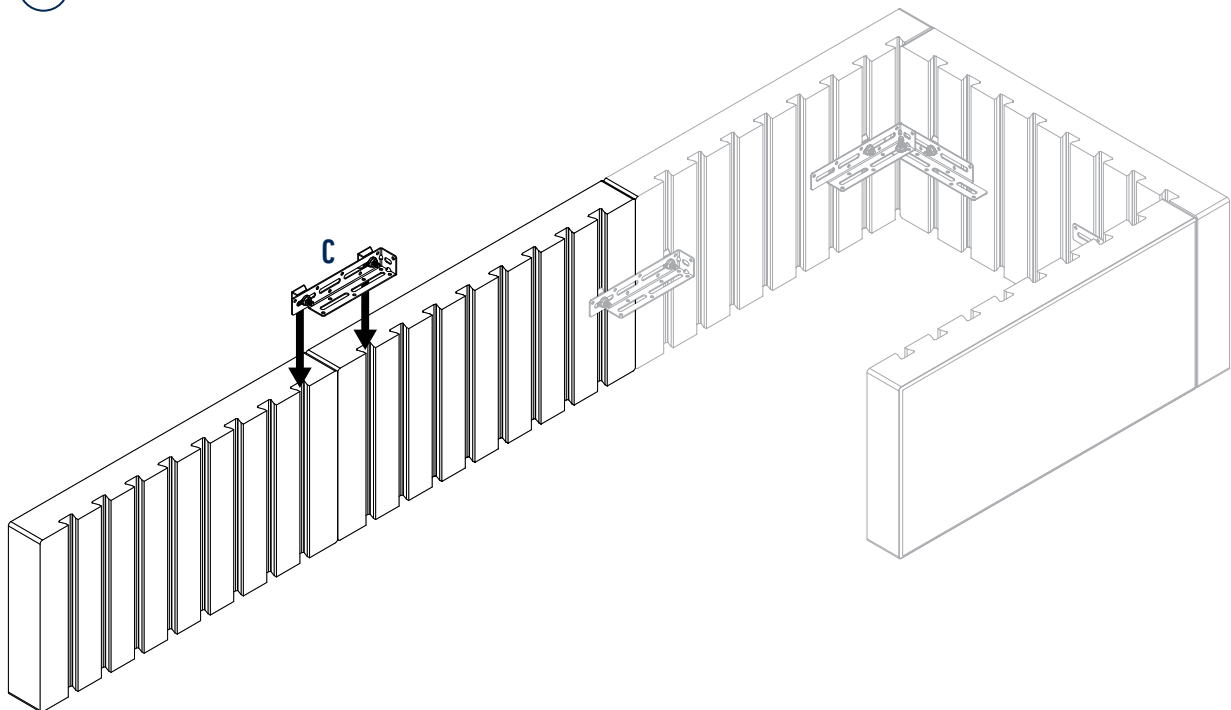



5

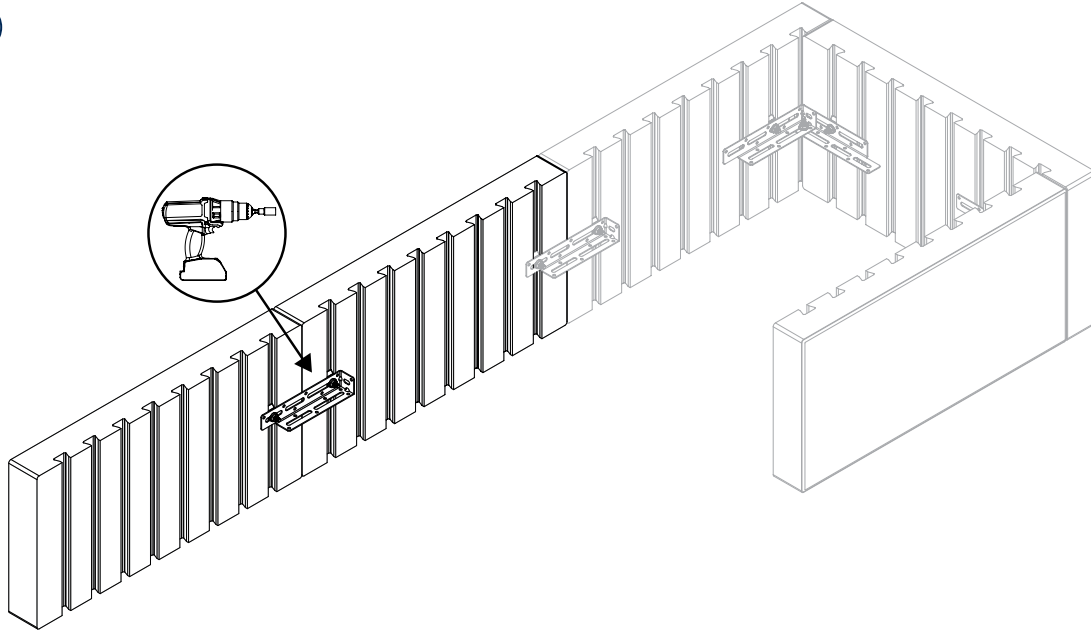

6

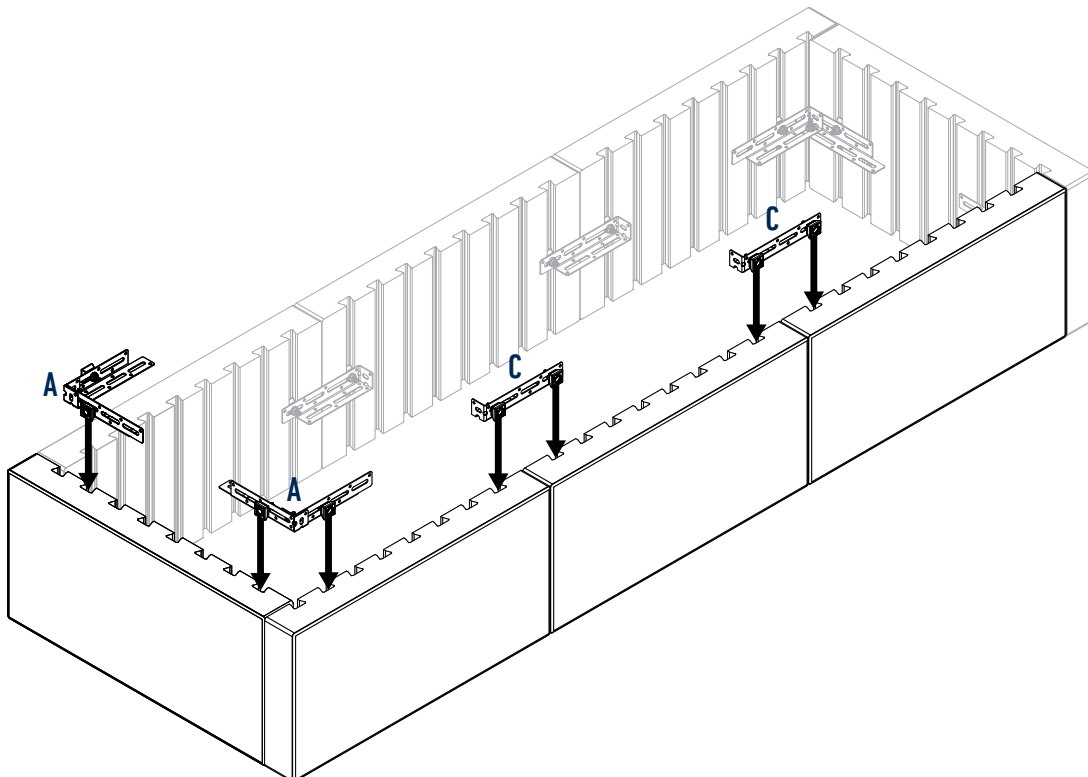



7

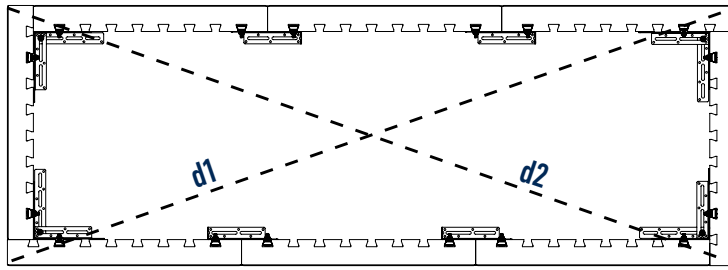

$d1 = d2$

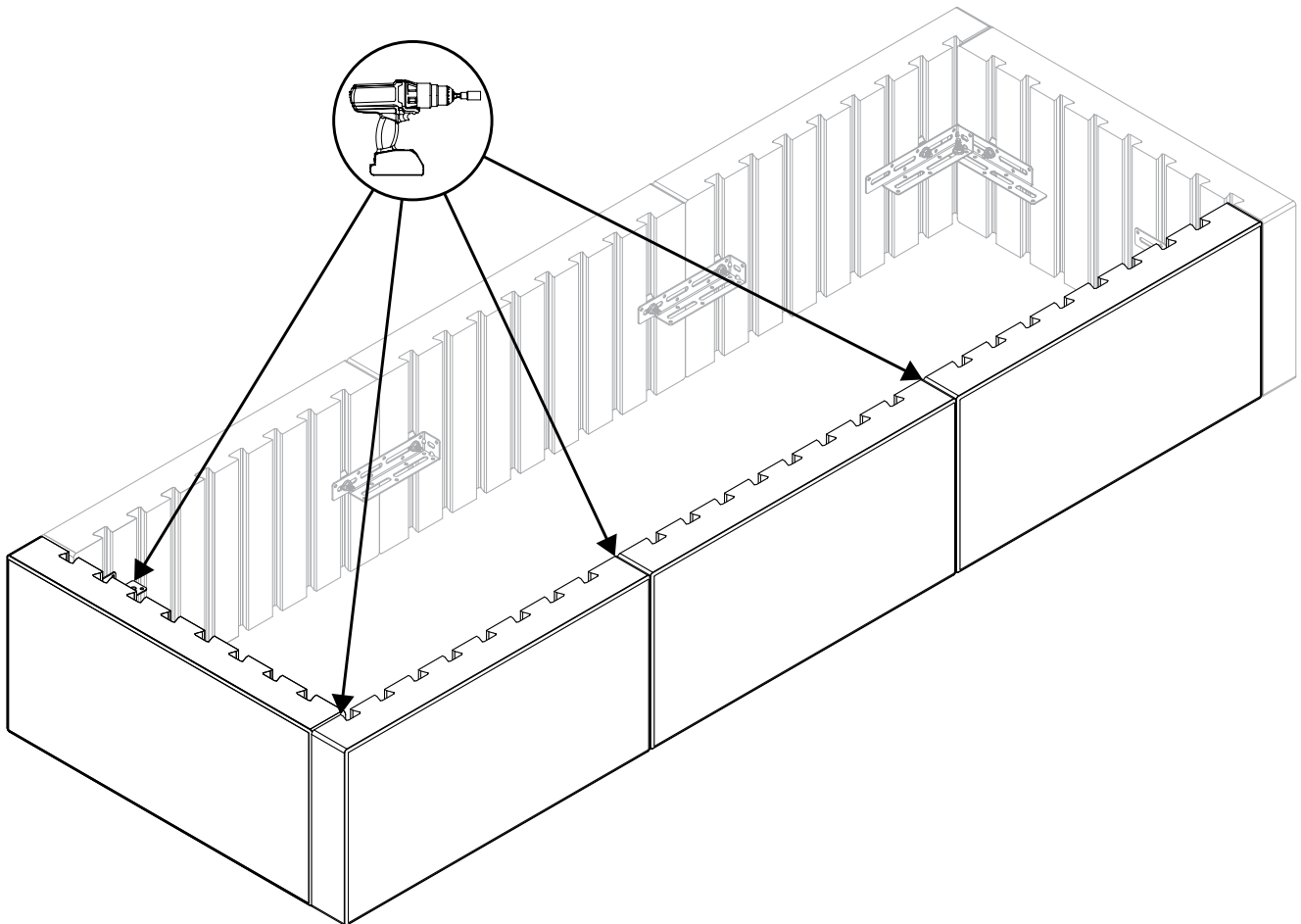



8

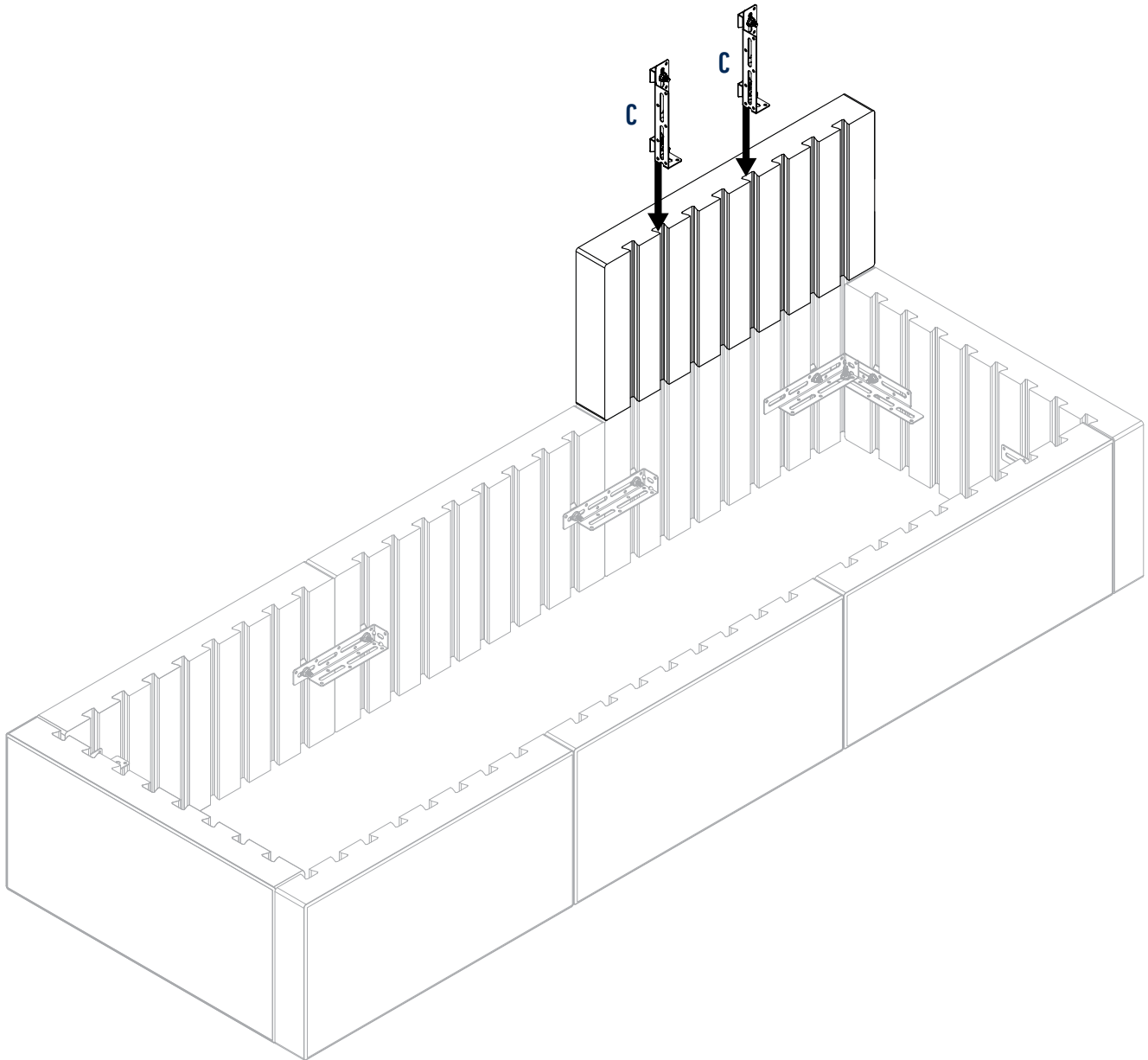



9

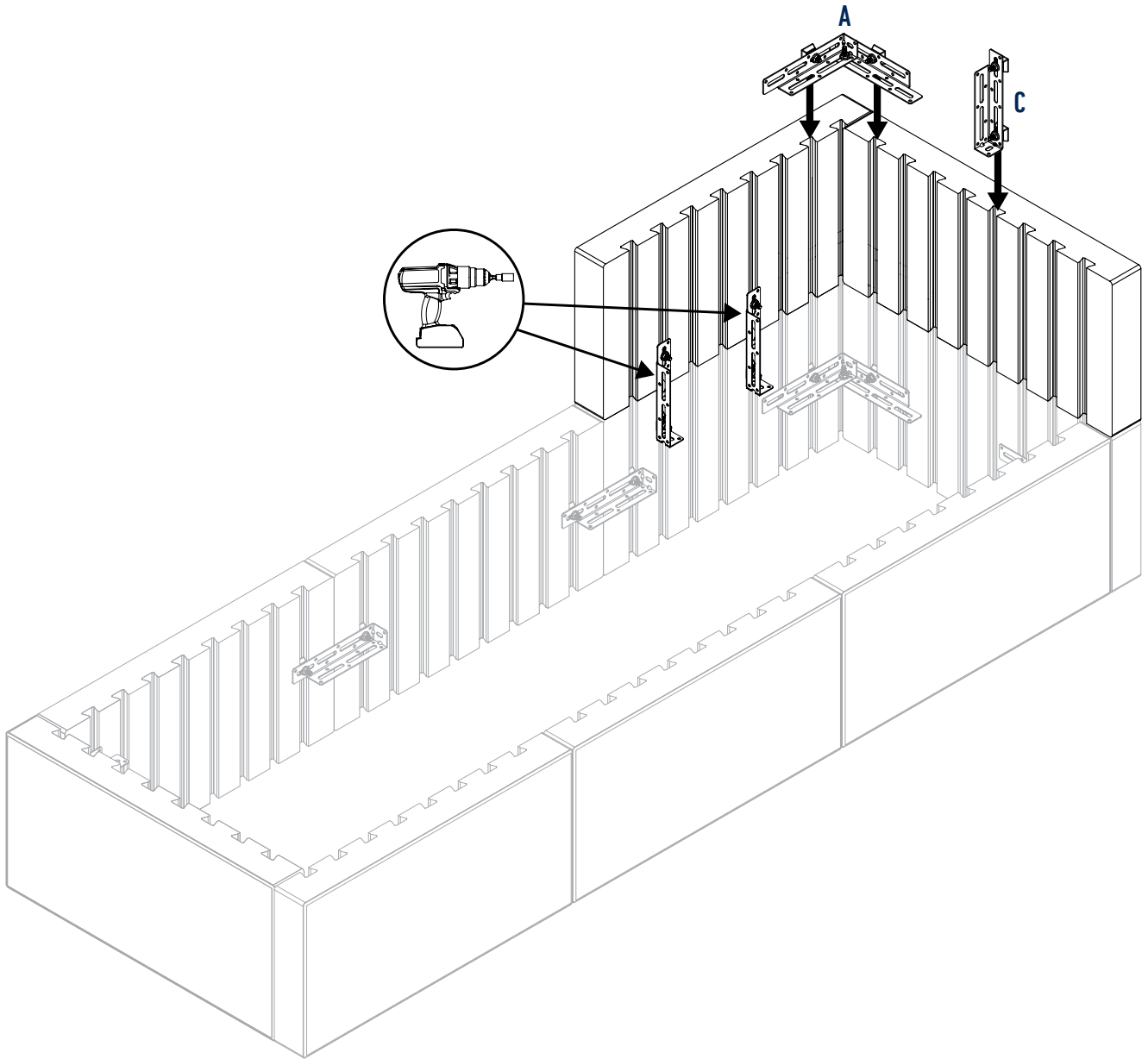



10

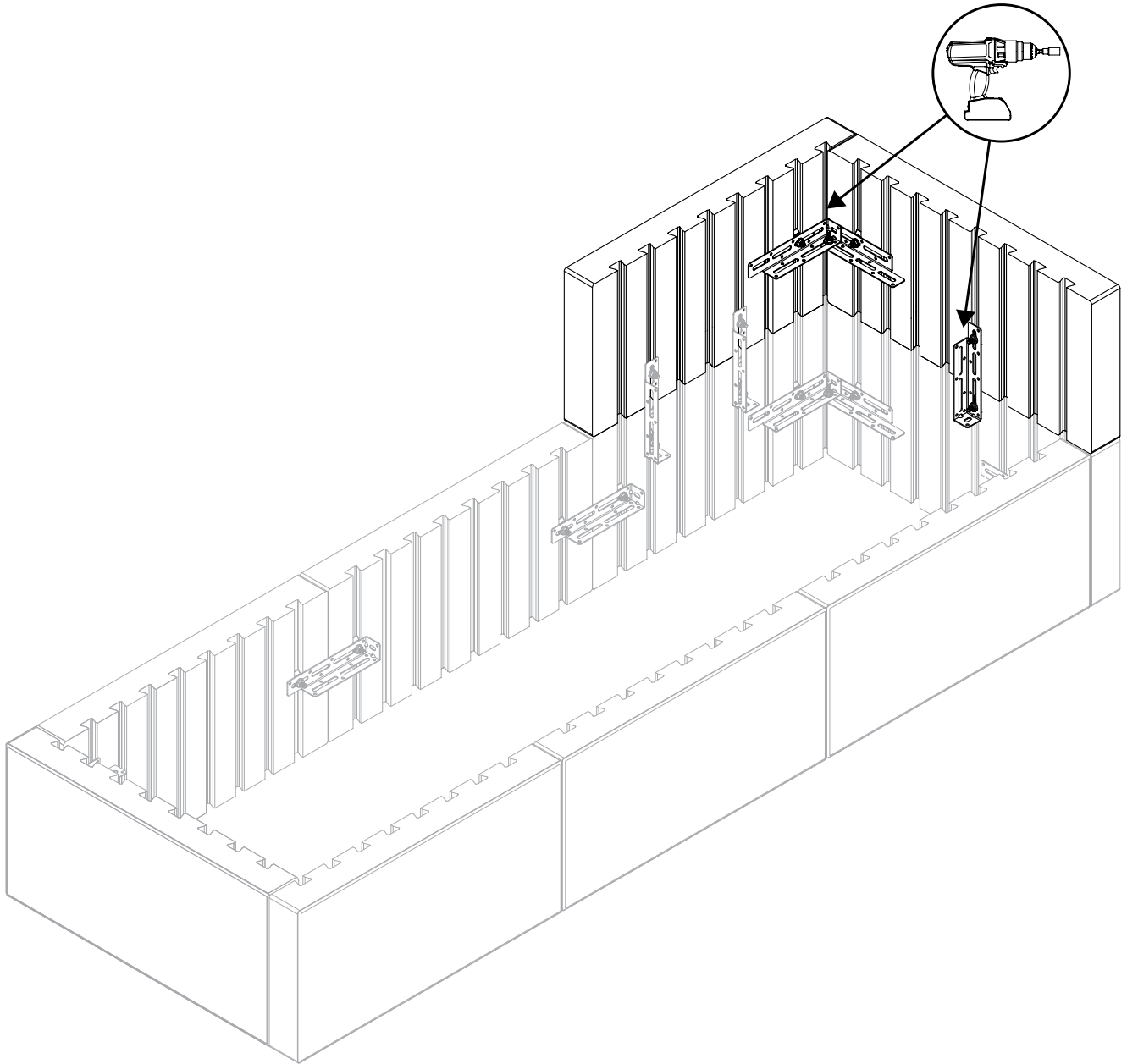



11

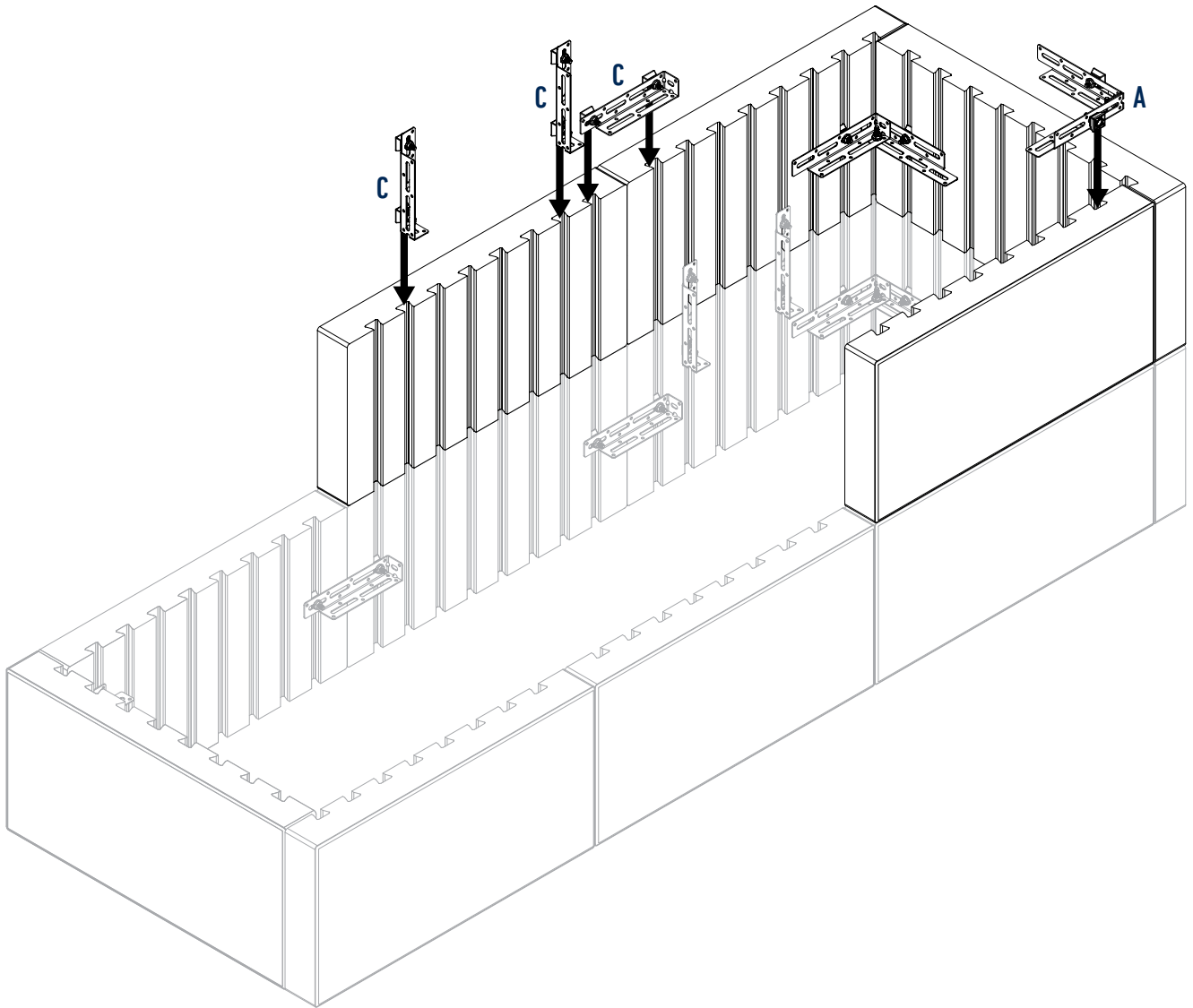



12

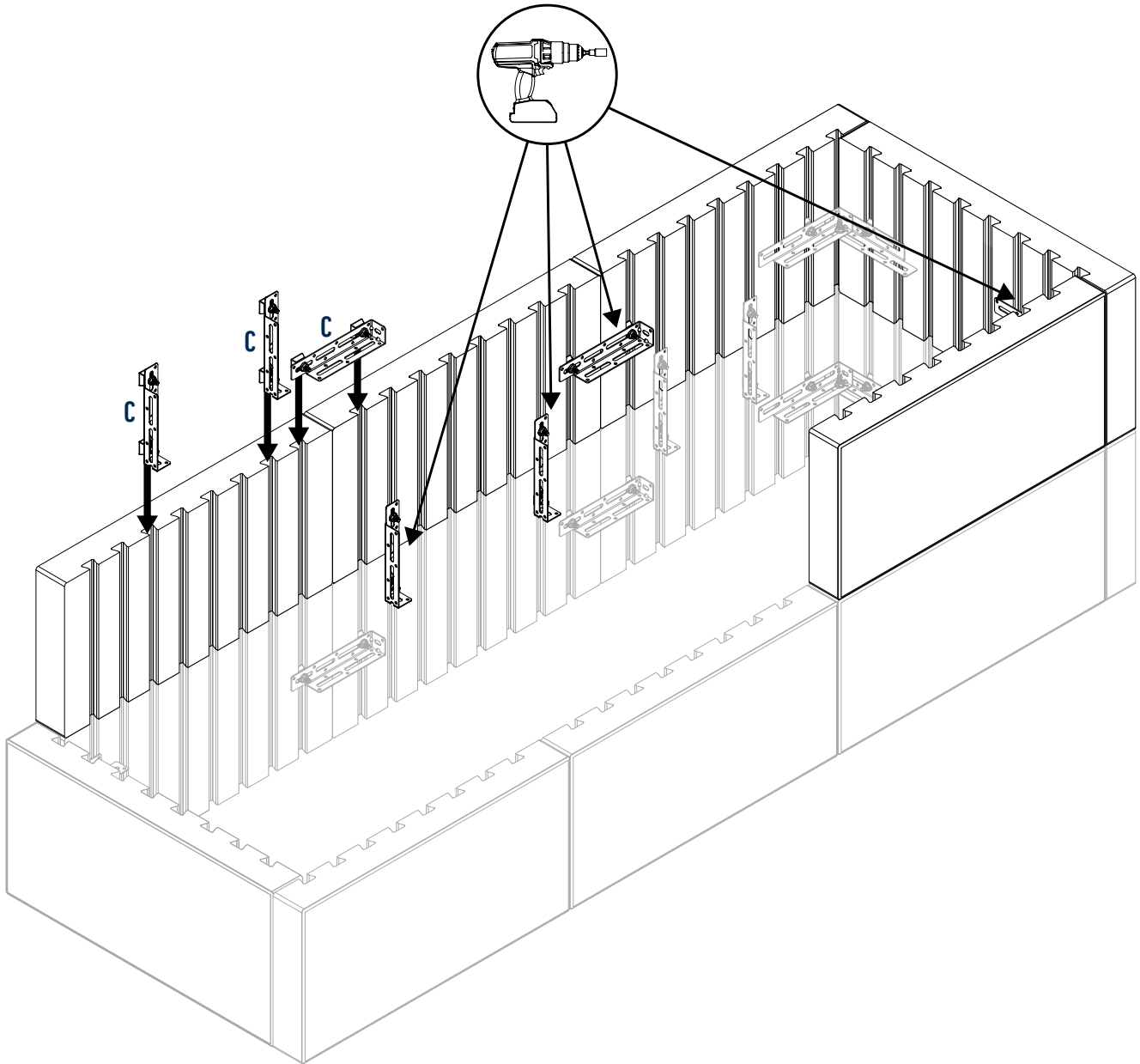



13

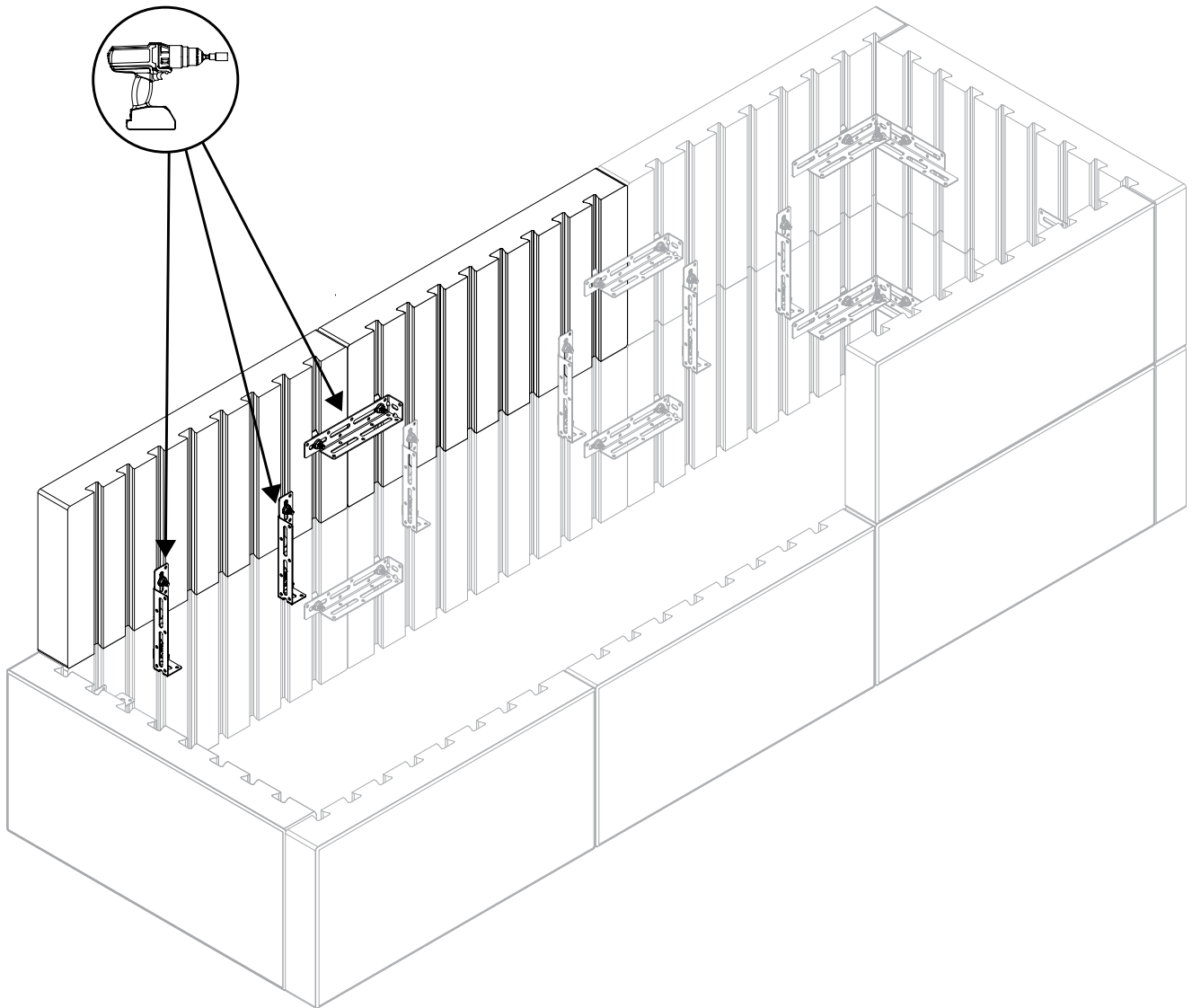



14

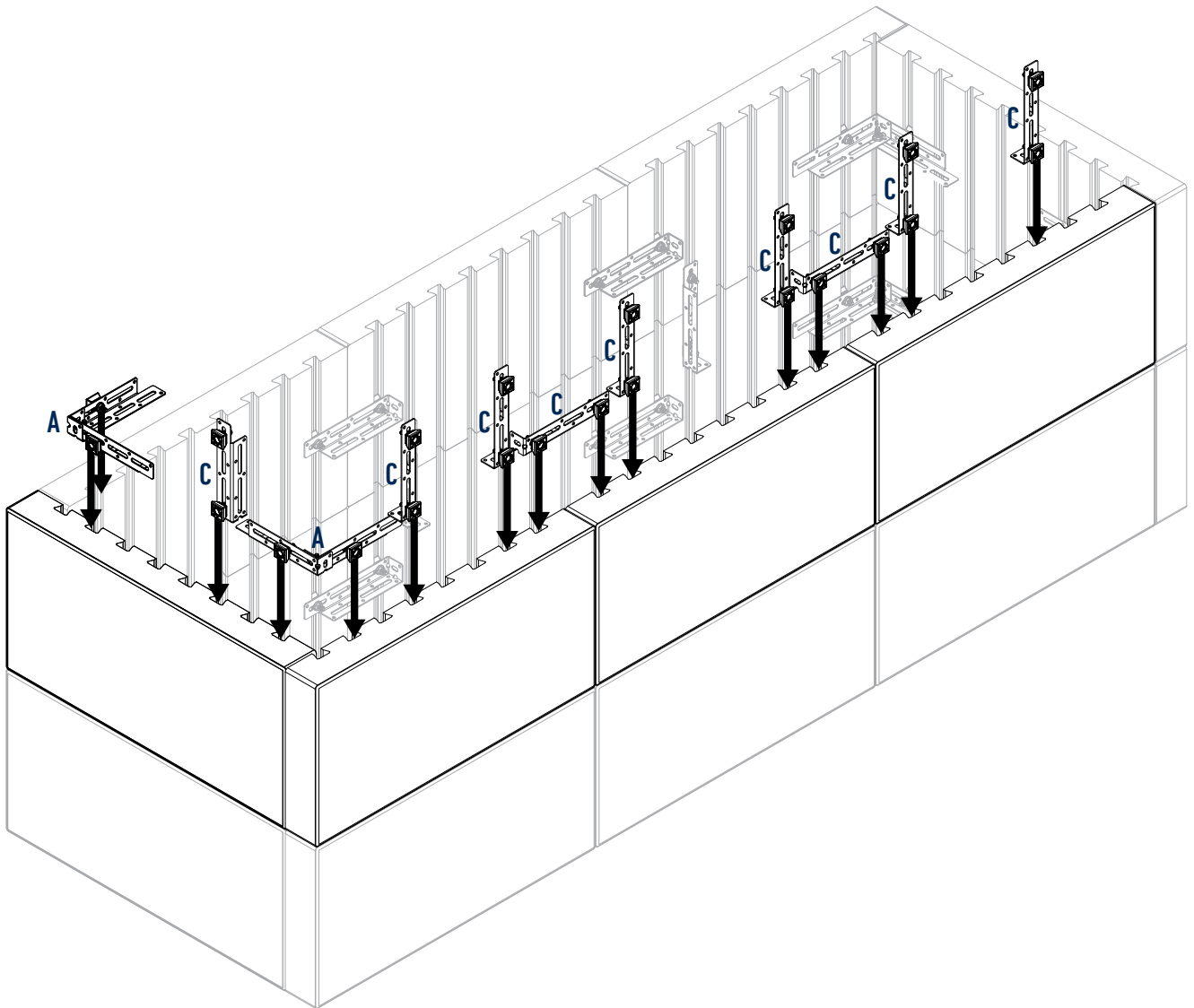



15

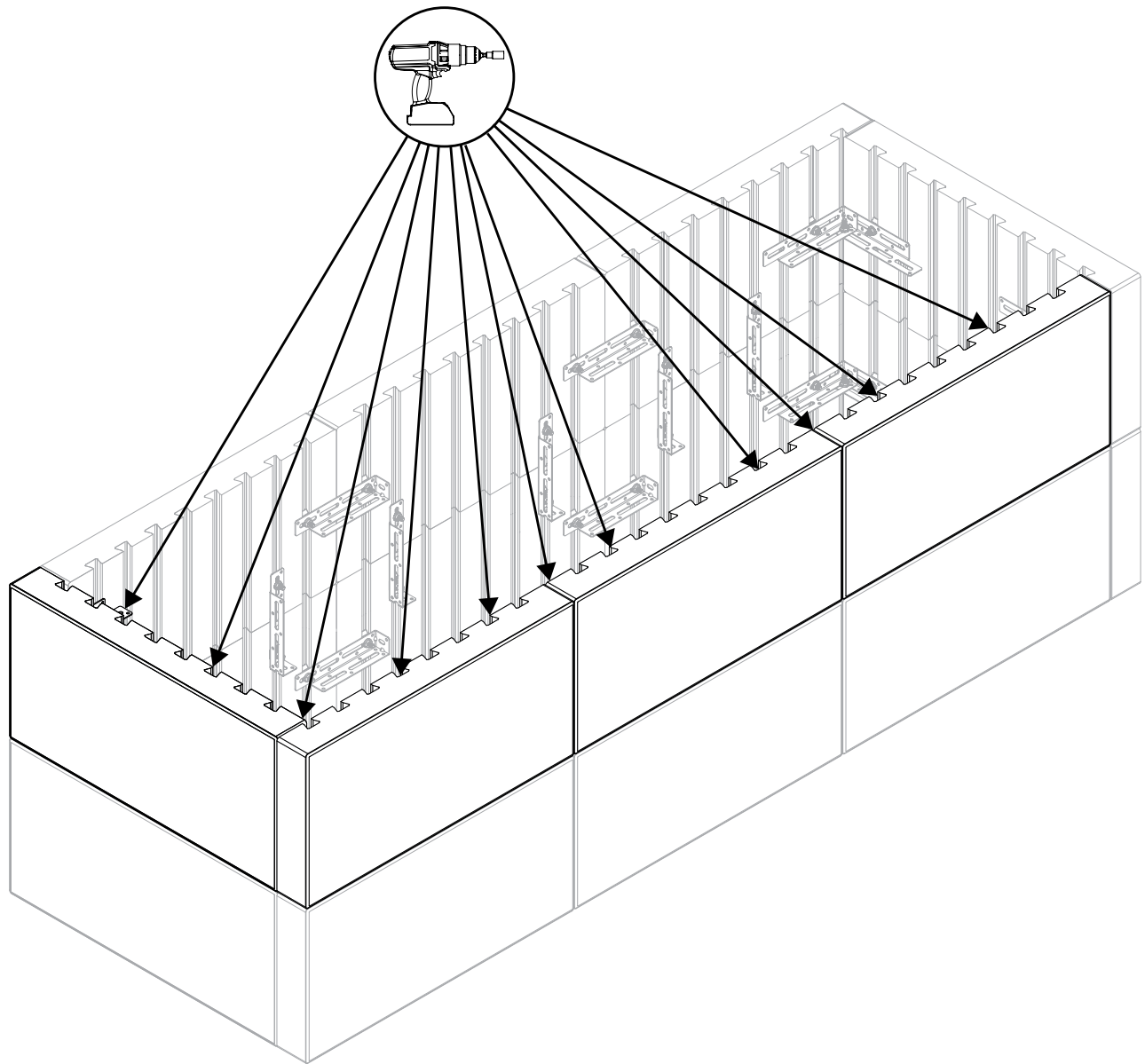



16

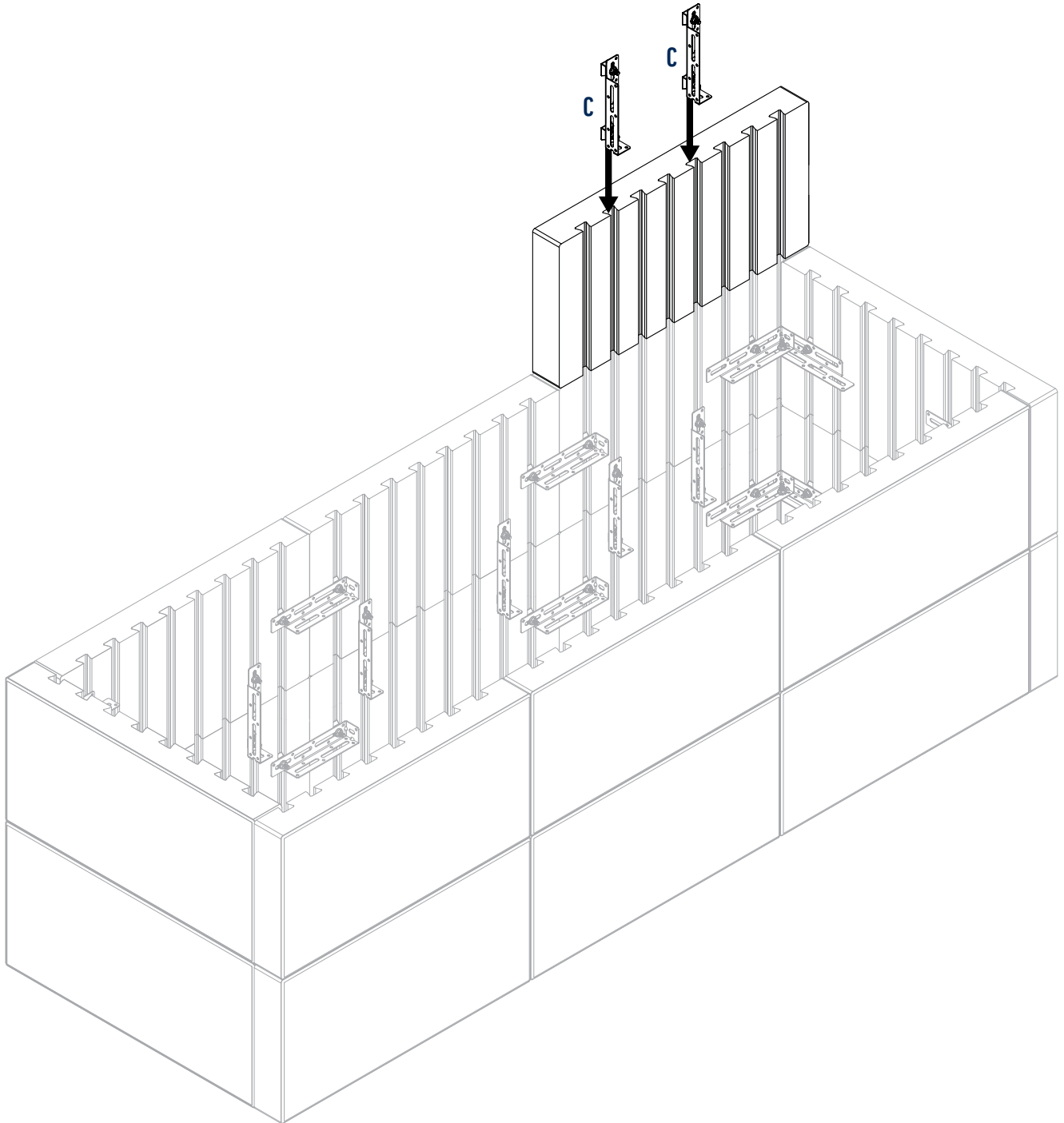



17

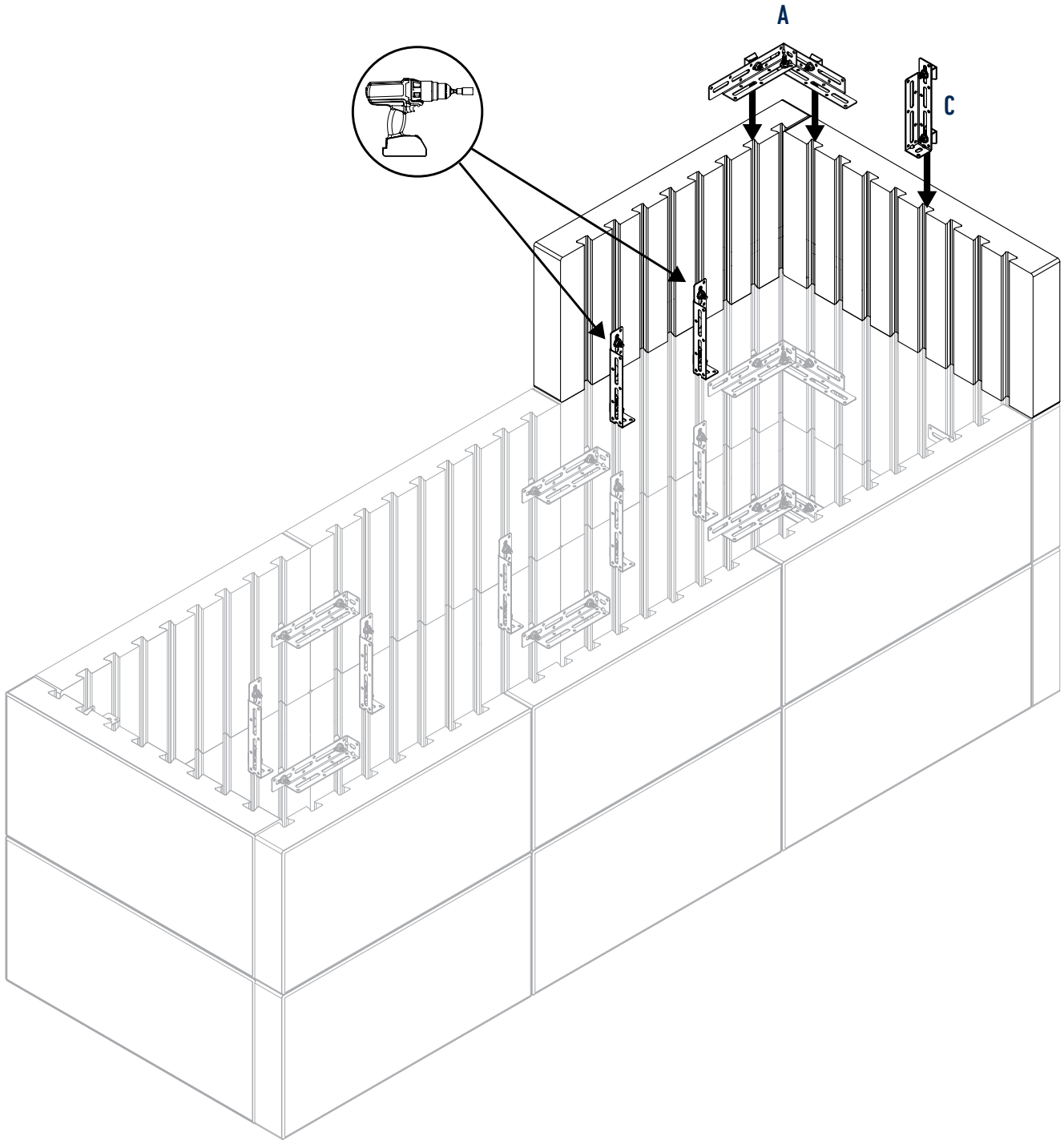



18

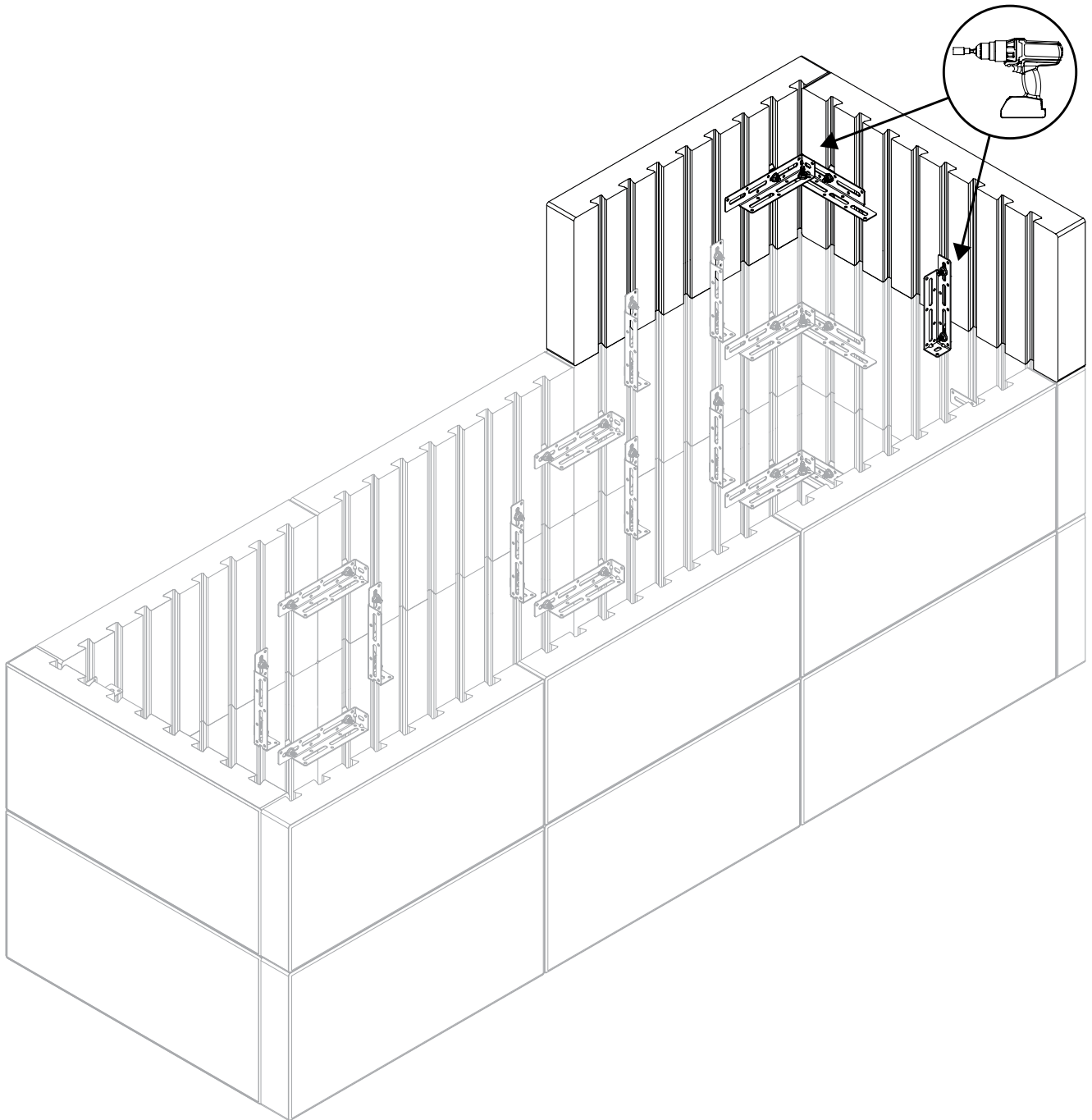



19

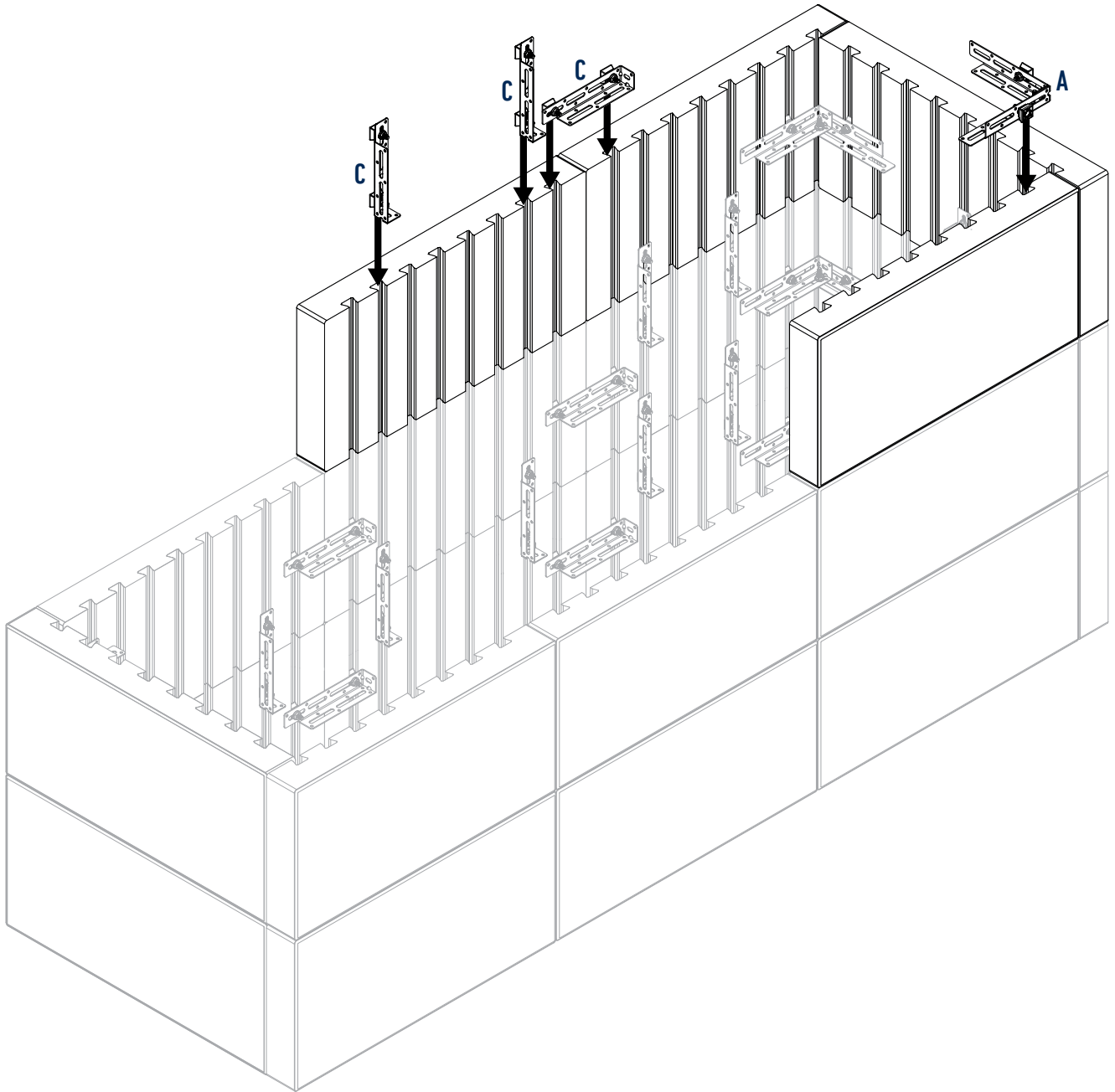



20

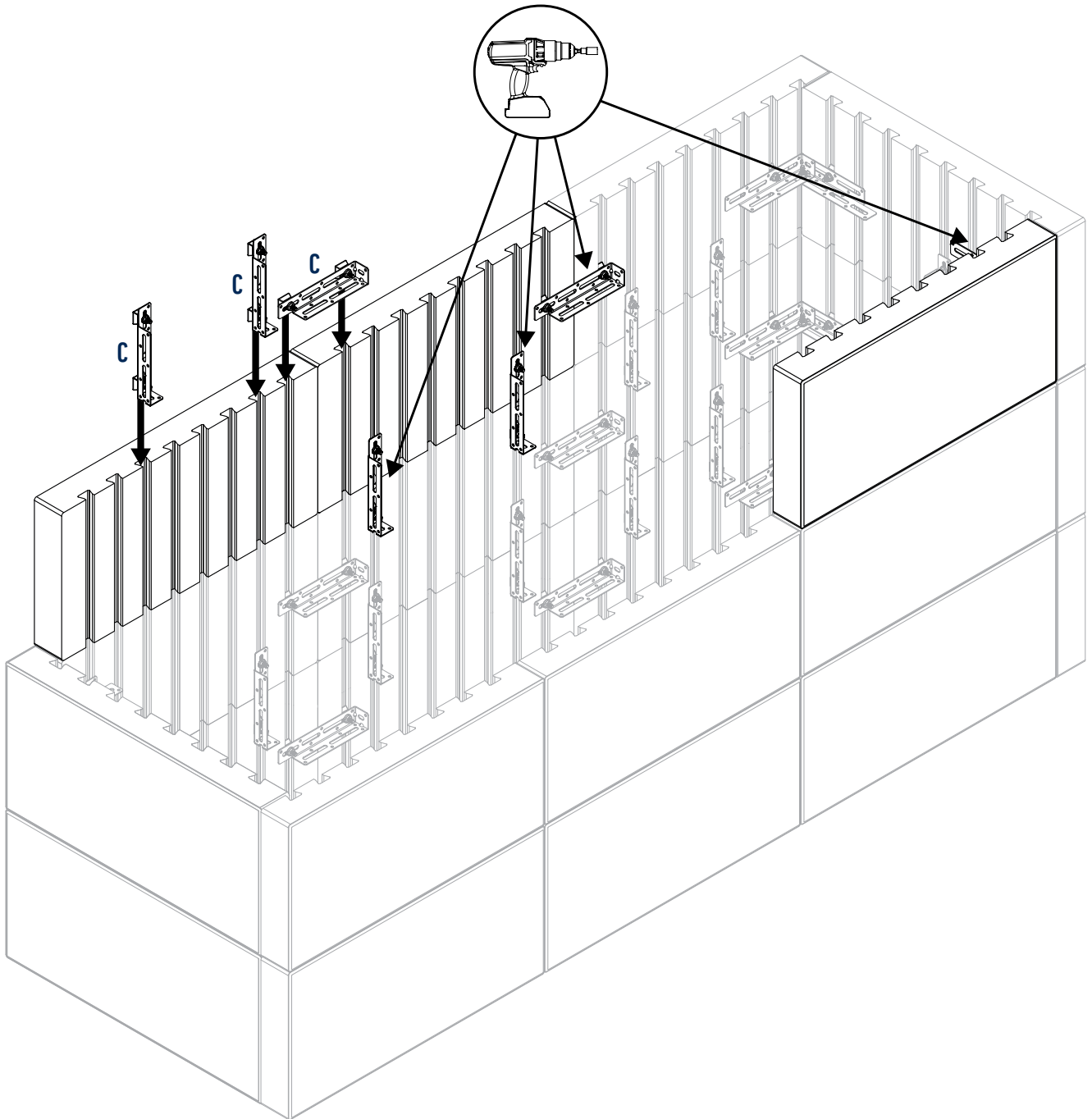



21

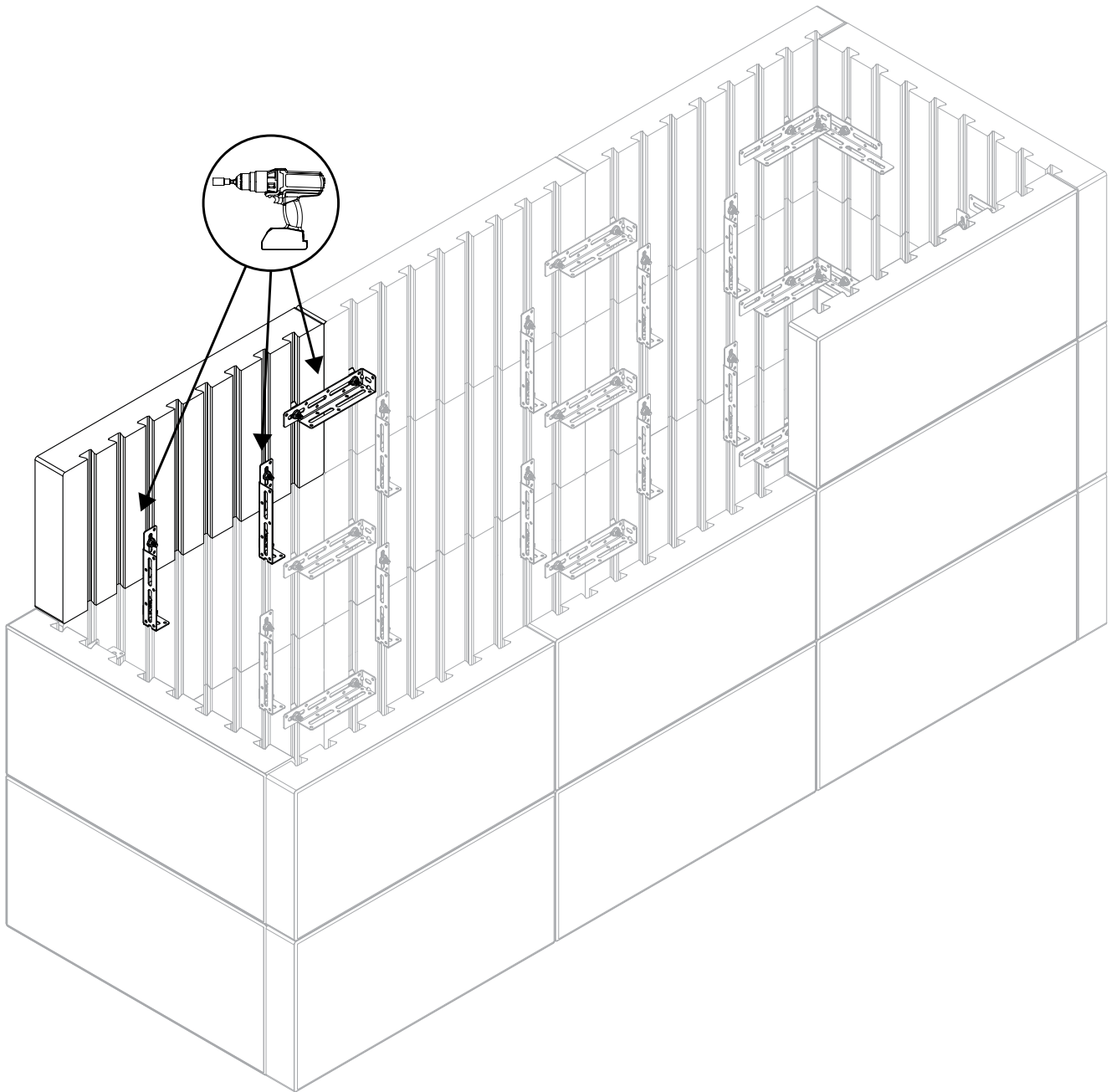



22

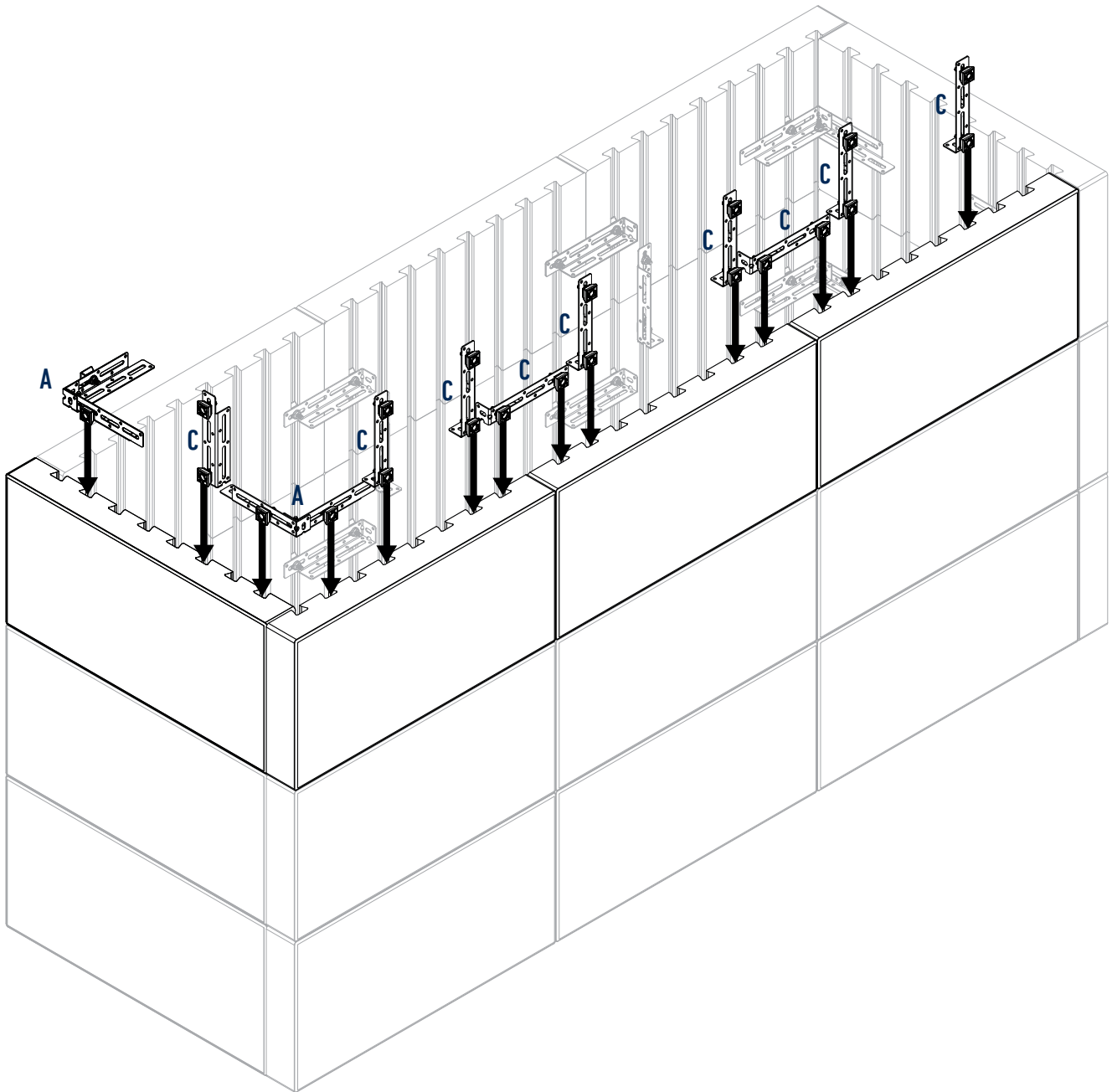



23

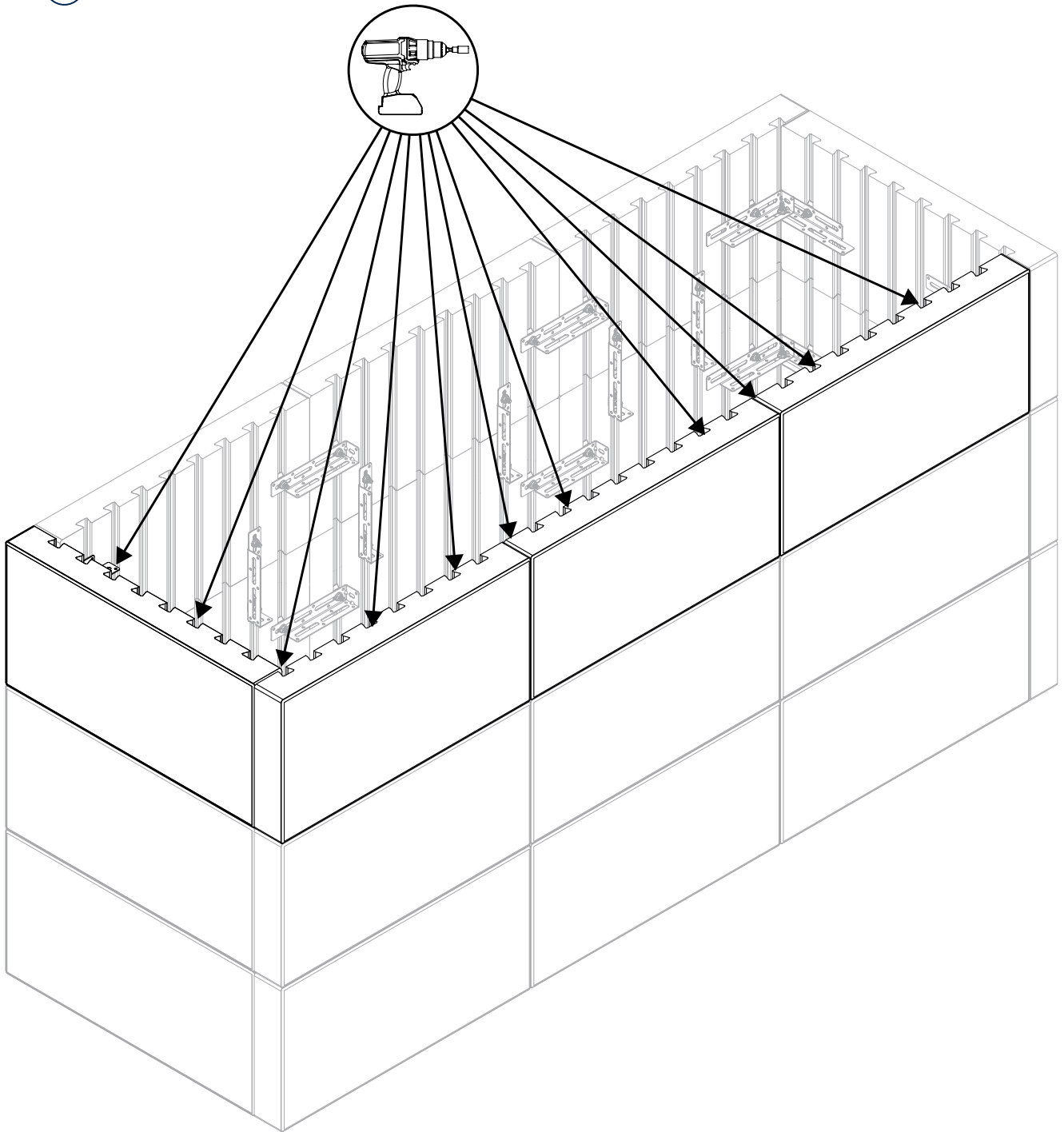



24

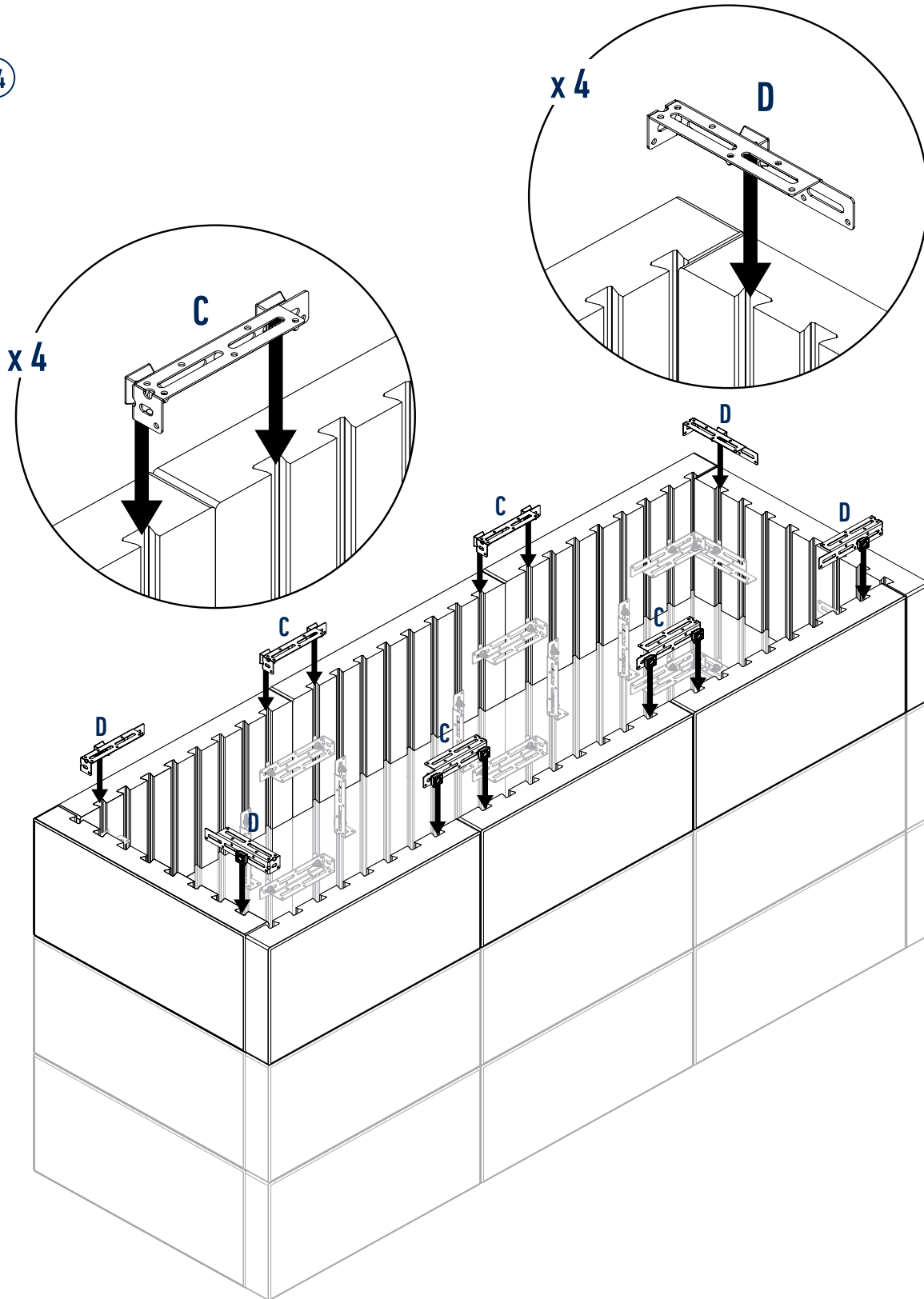



25

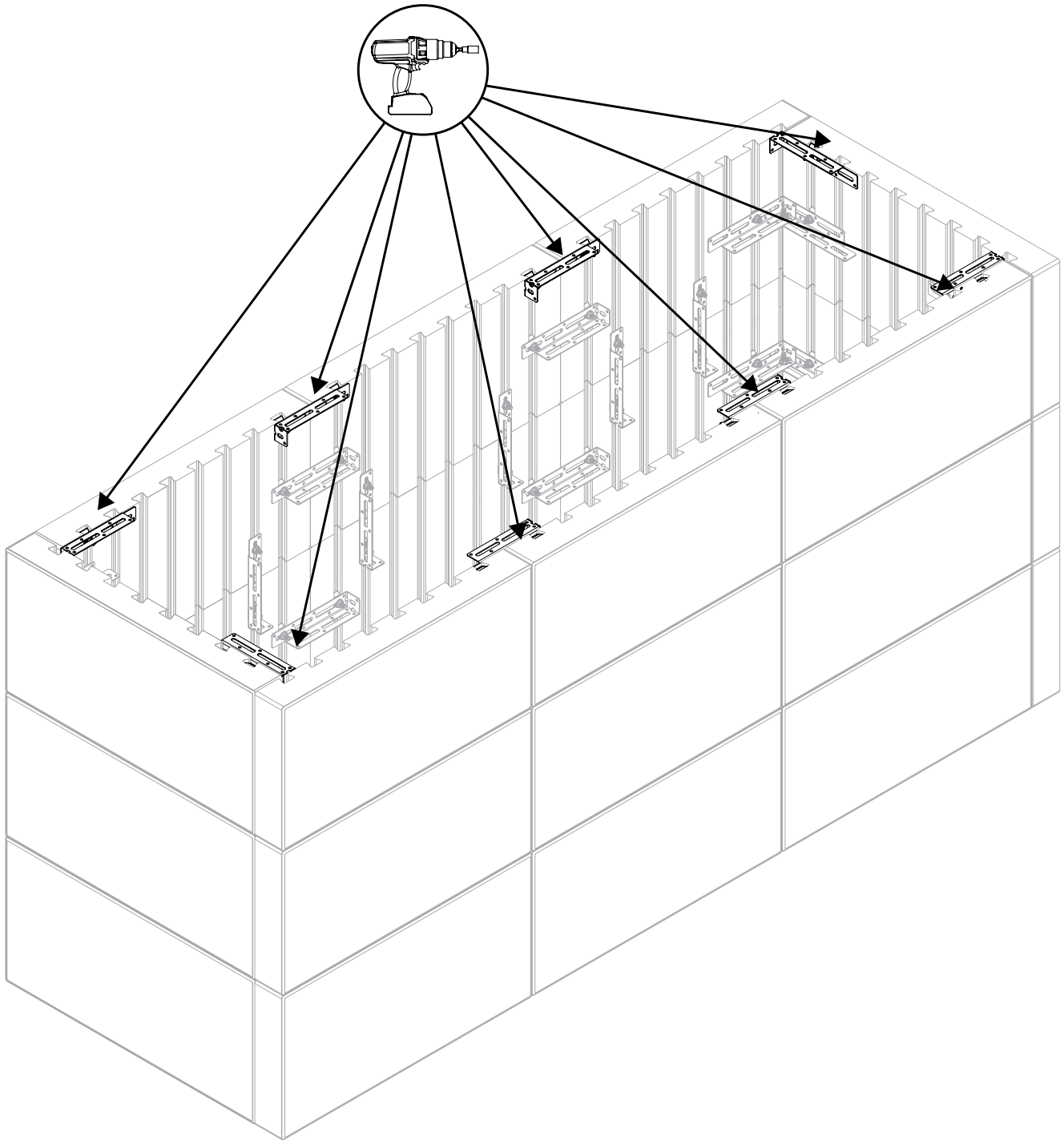



26

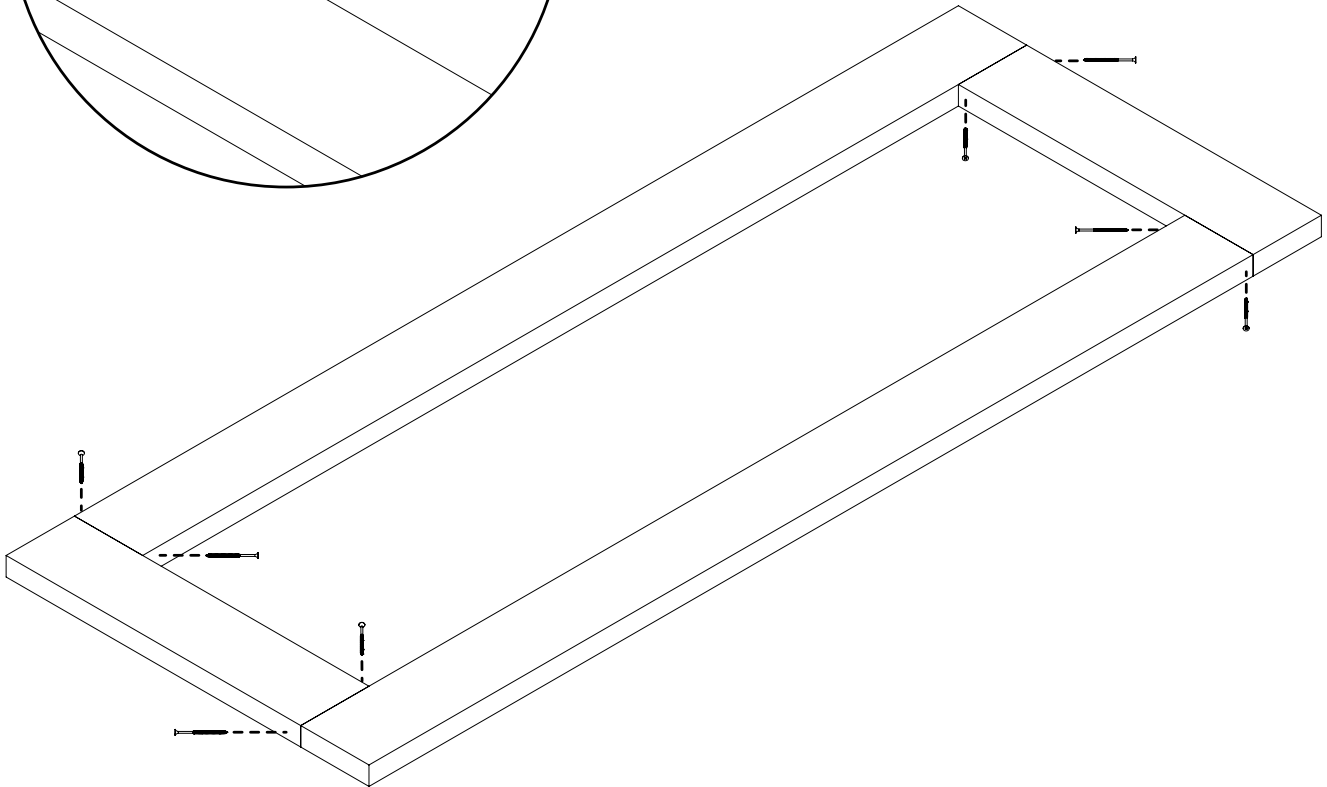
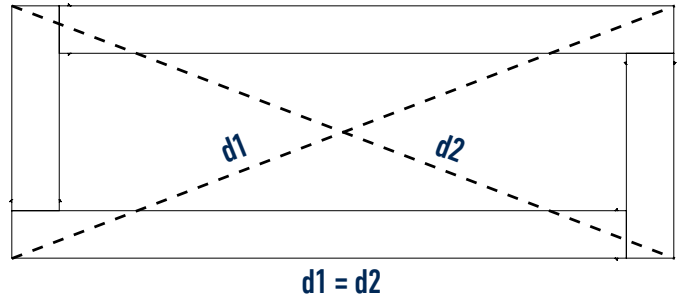
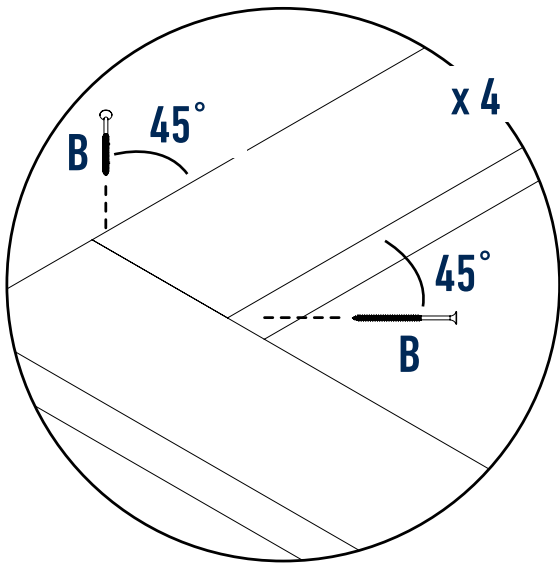



27

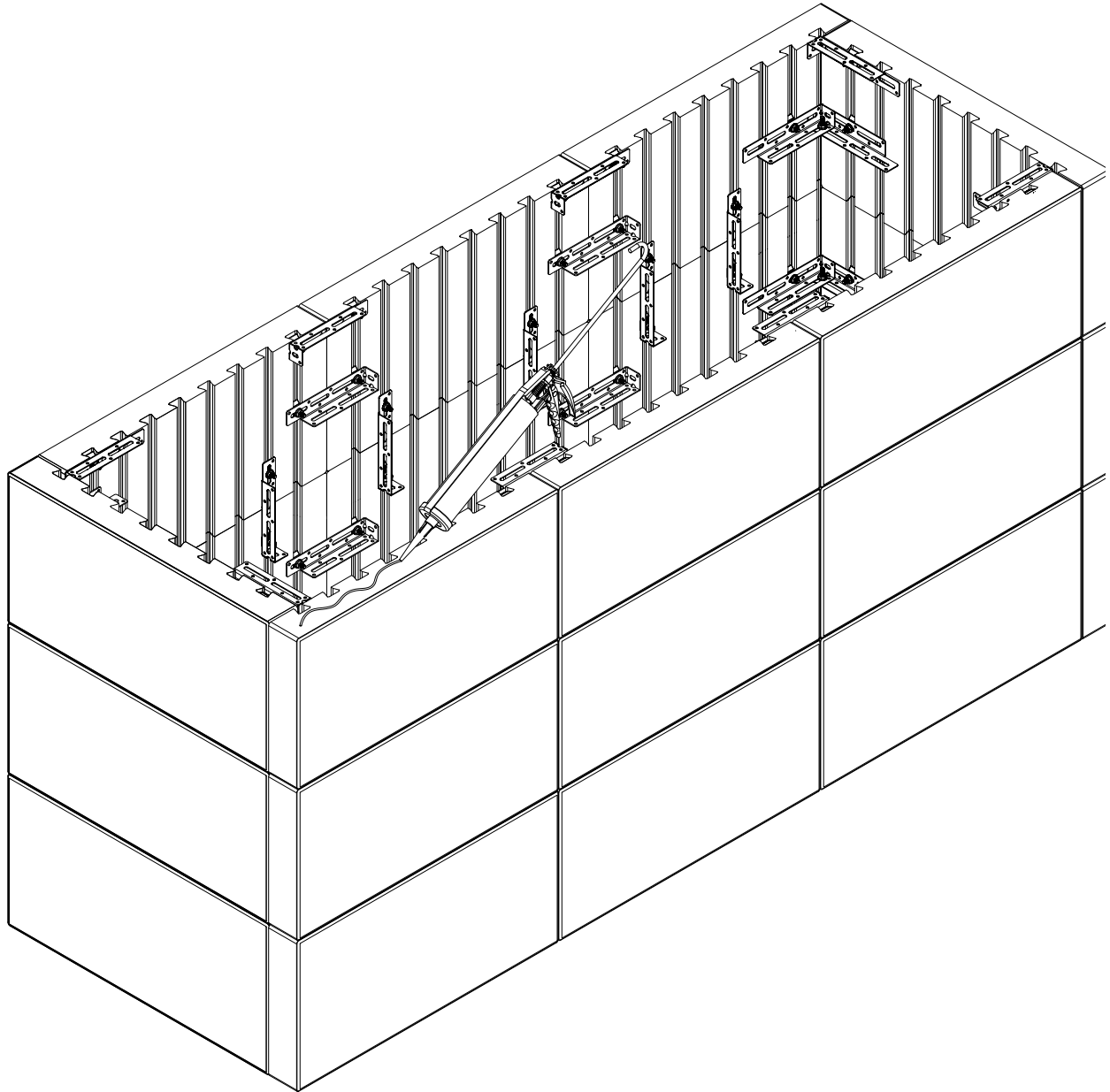



28

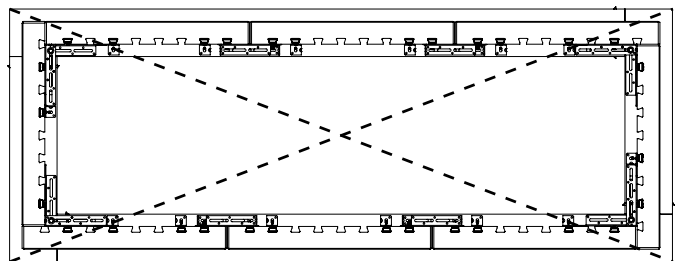
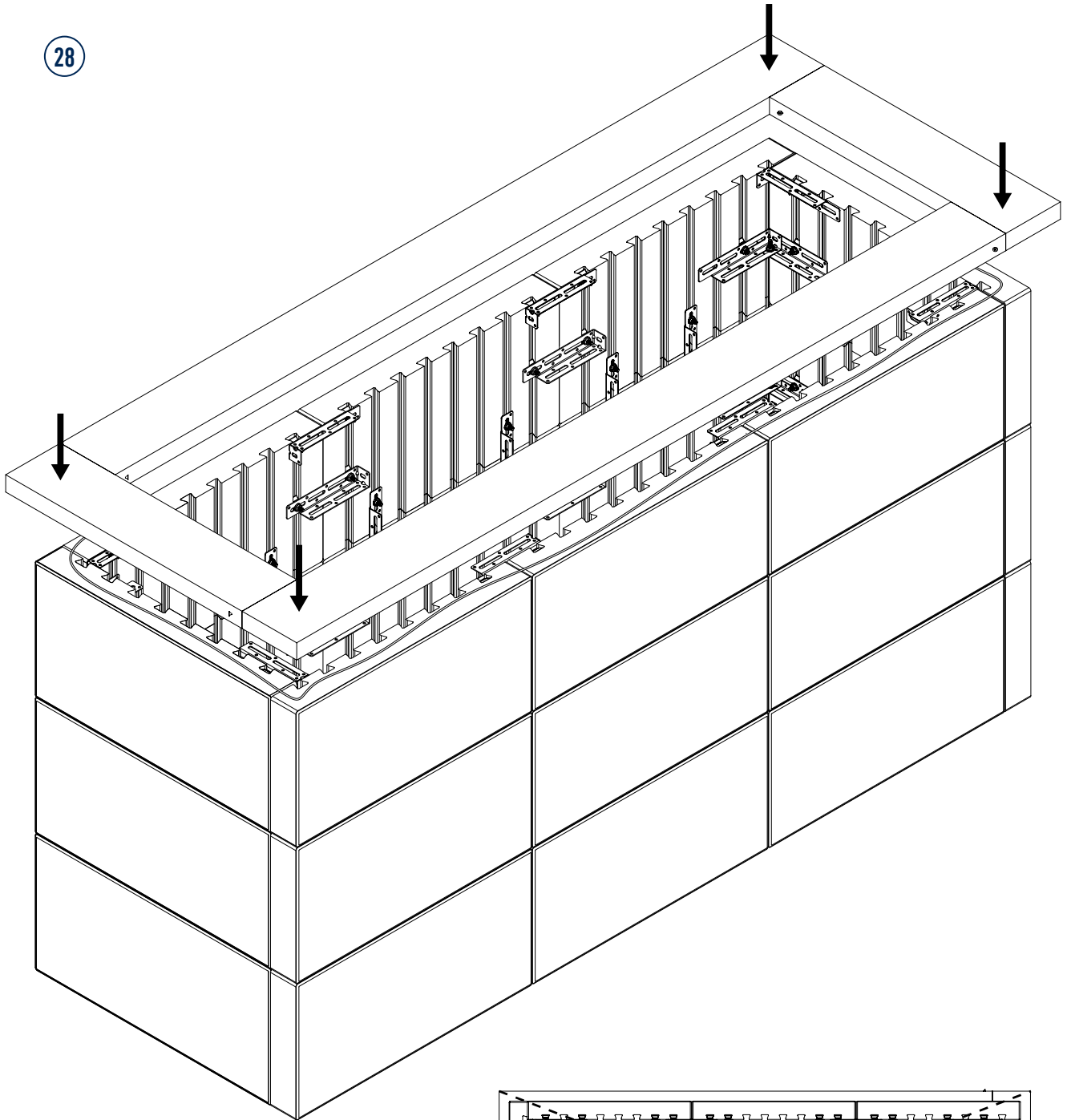



29

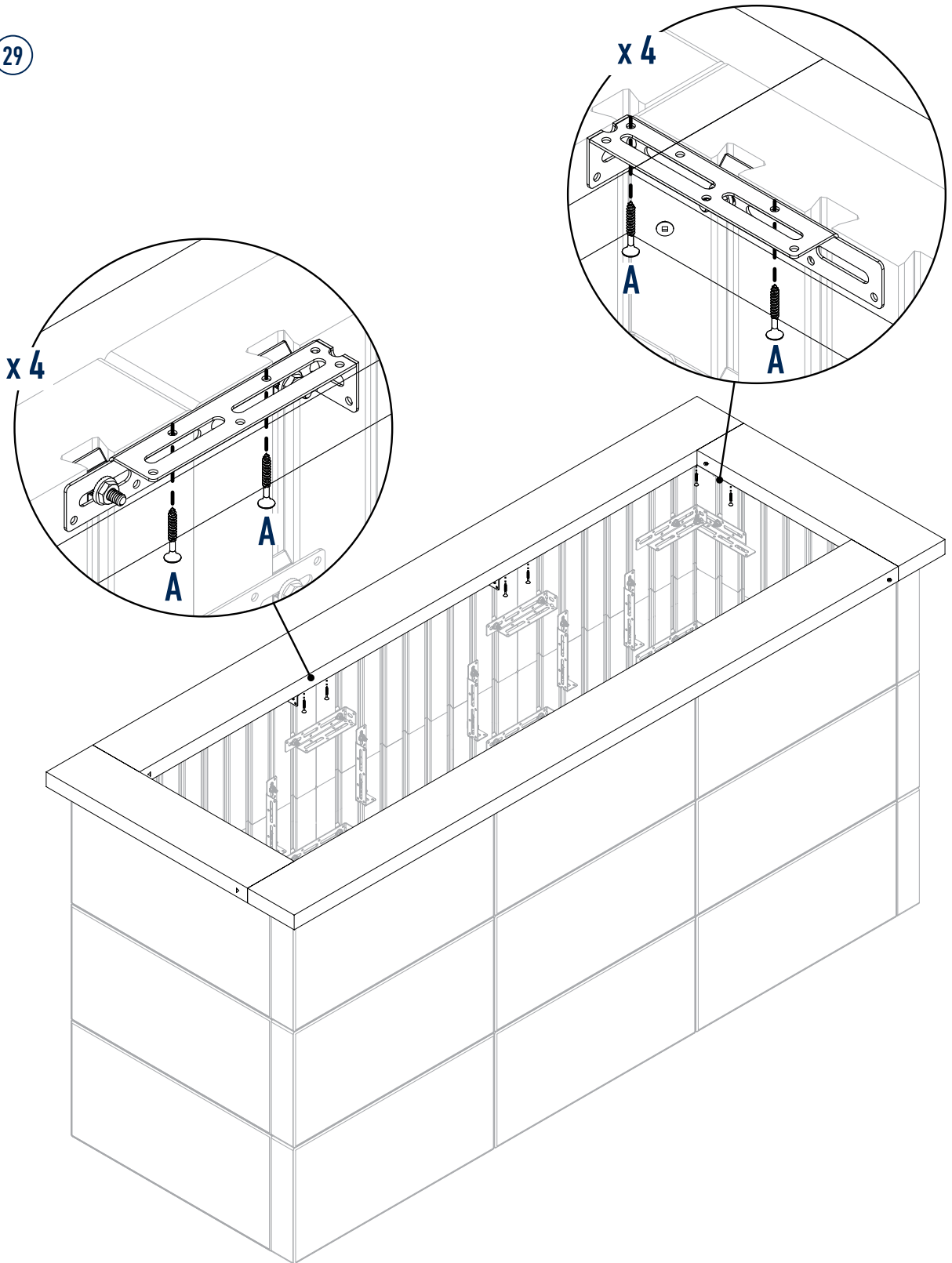

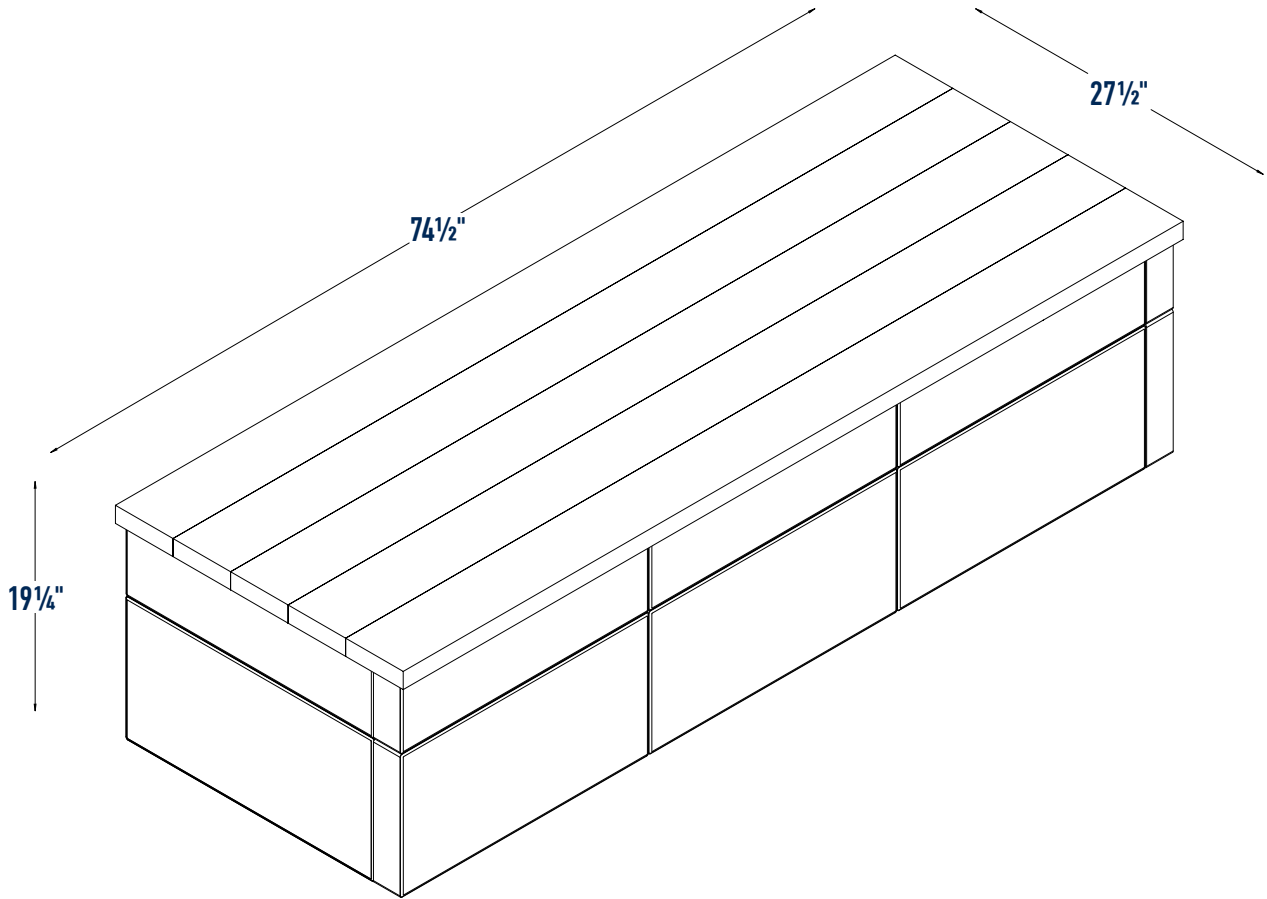

COMPONENTS

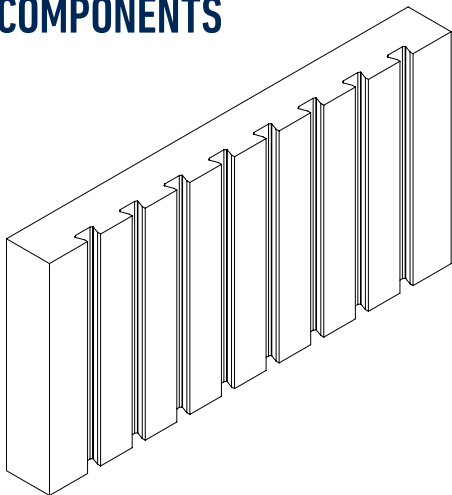

Large Panel (x8)
12" x 24"

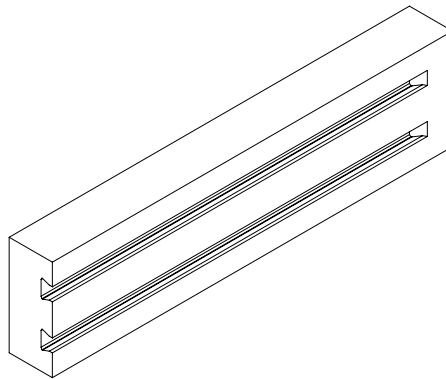

Small Panel (x8)
6" x 24"

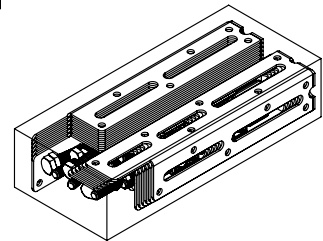

Hardware Kit (x3)

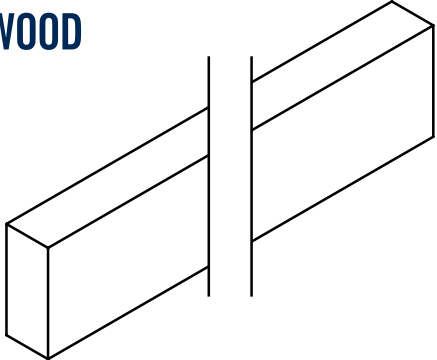
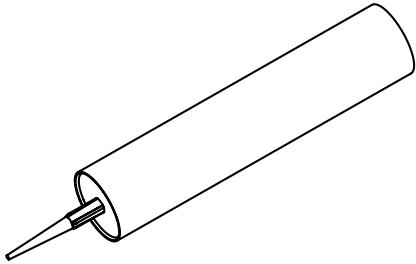
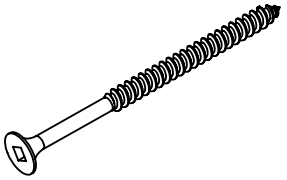
<p>2" x 6" x 8' PRESSURE TREATED WOOD</p> 	x5	<p>OUTDOOR SILICONE</p> 	x1	<p>#8 2½" DECK SCREW</p> 	x30
--	-----------	---	-----------	---	------------

WOOD CUTS

**1 = 74½"
2 = 20½"**

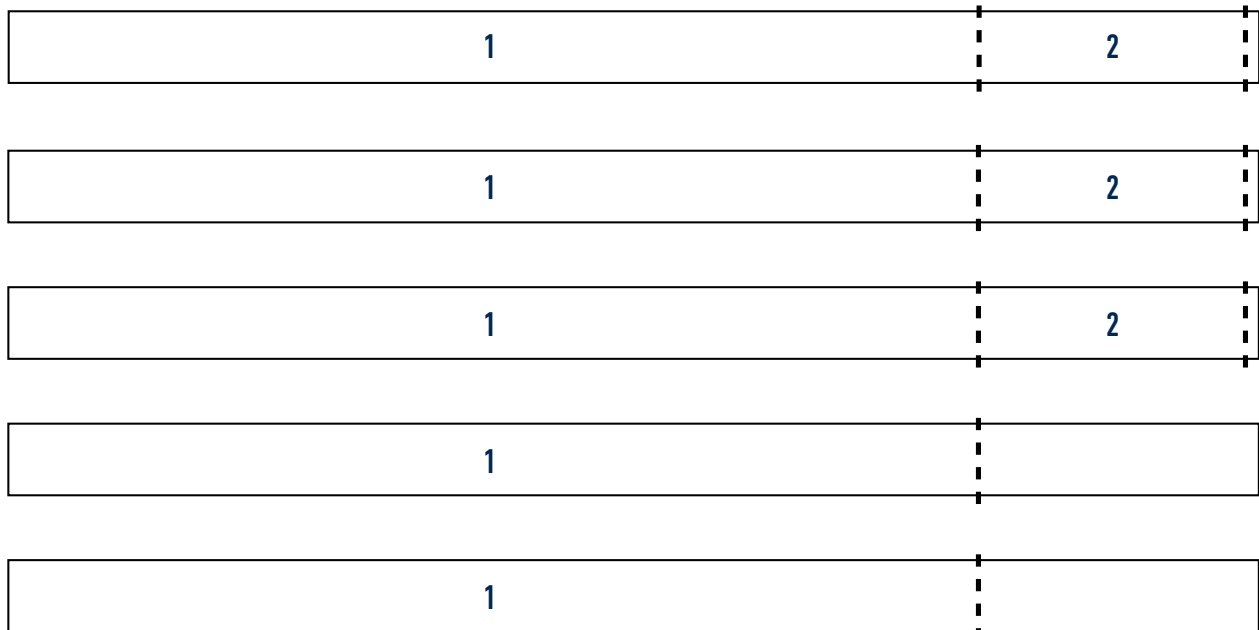

BRACKET A **x4**

x2
x3
x1
x3
x2

BRACKET B **x4**

x2
x1
x1
x1

BRACKET C **x4**

x1
x2
x2
x2

<p>BRACKET H x12</p>	<p>ASSEMBLY I x32</p> <p>Use with BRACKETS B and H during build</p>	<p>J x32</p>
	<p>x1 x1</p>	
	<p>1</p>	



1

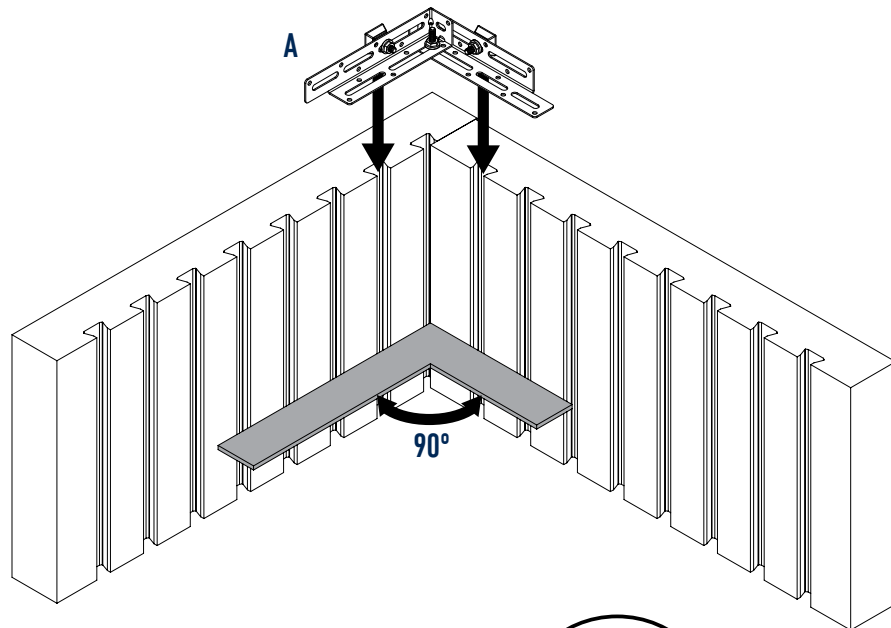

2

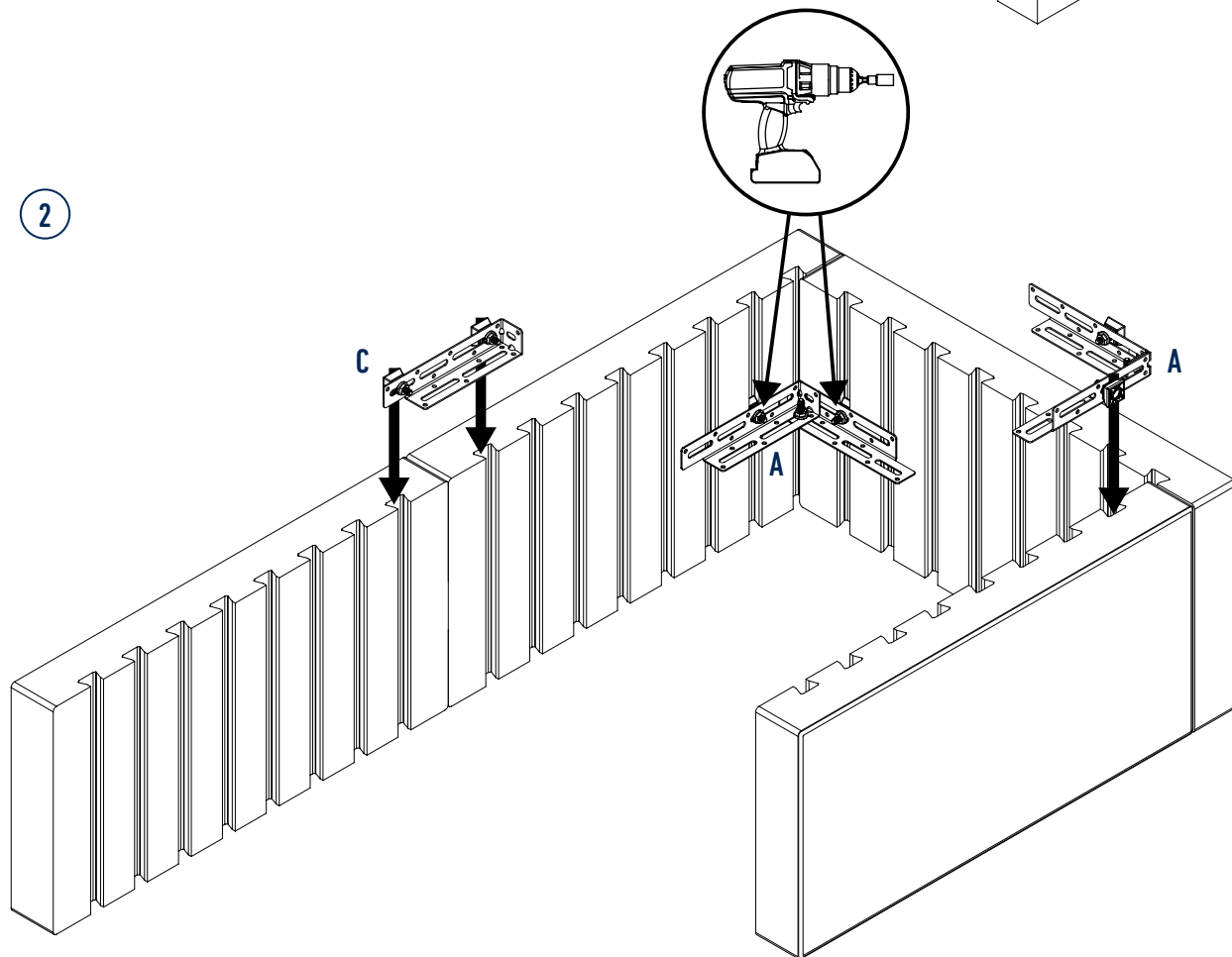



3

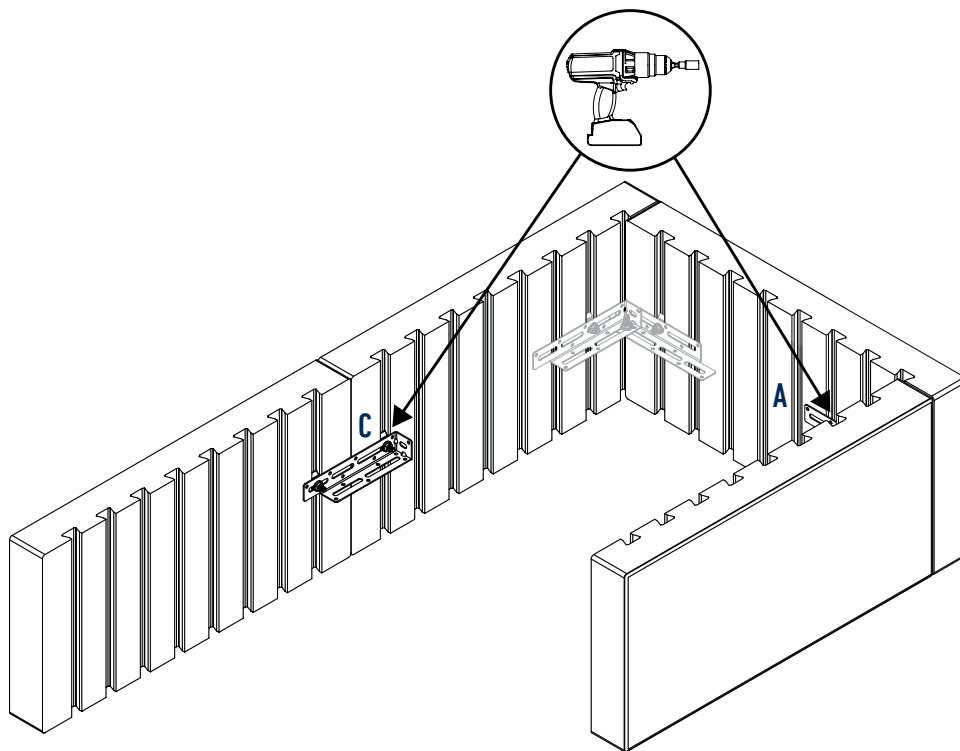

4

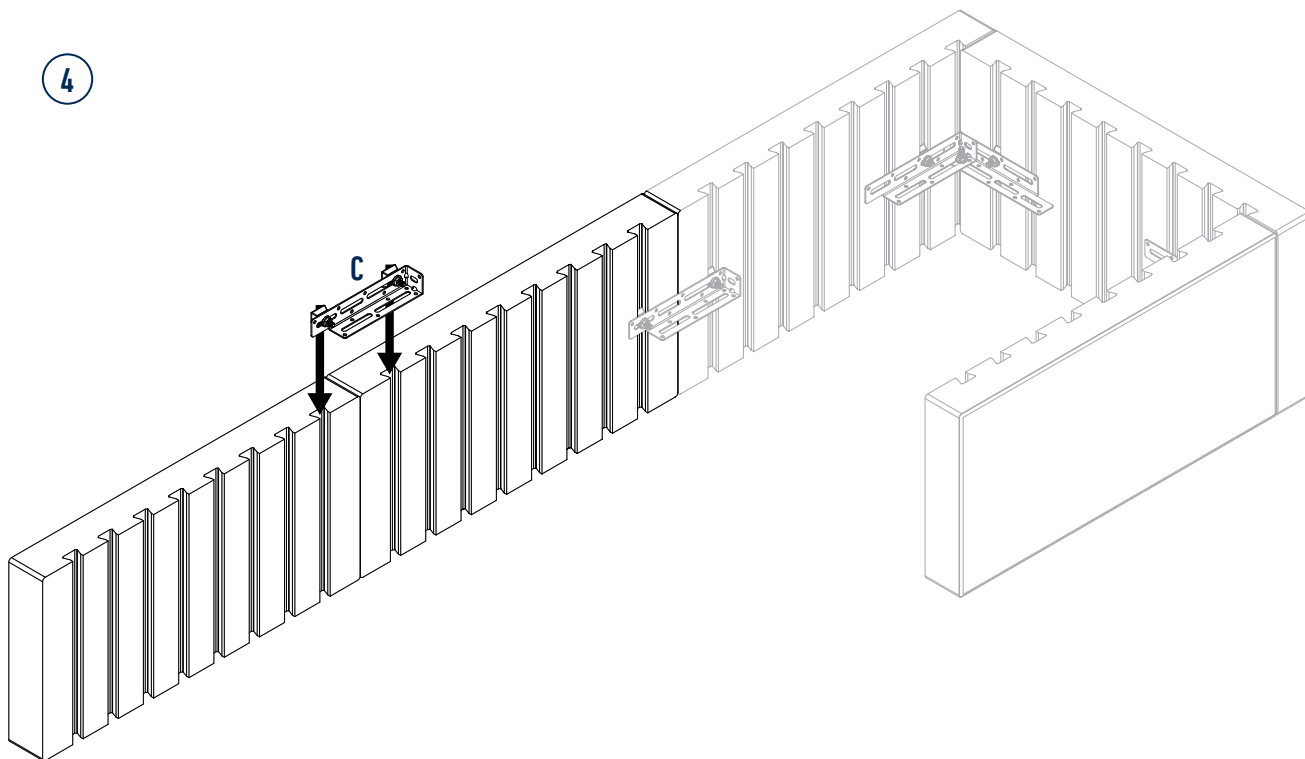

5

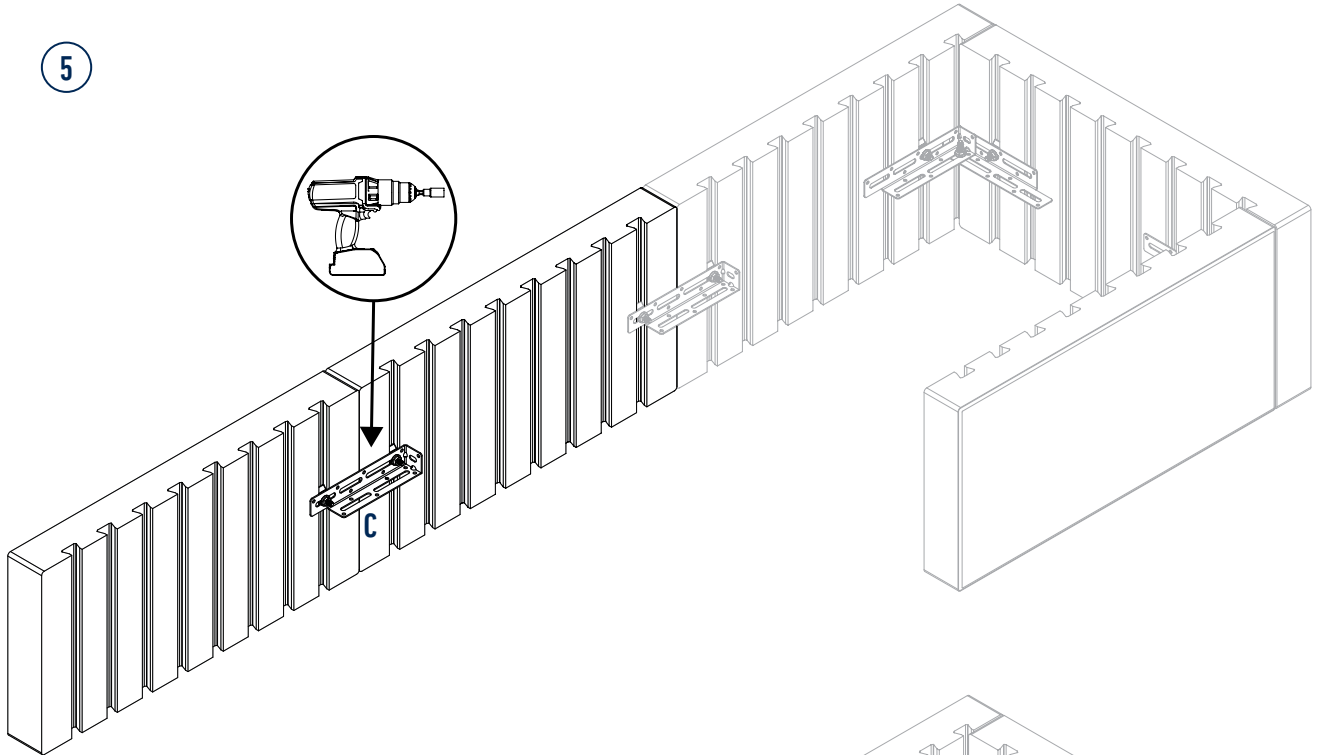

6

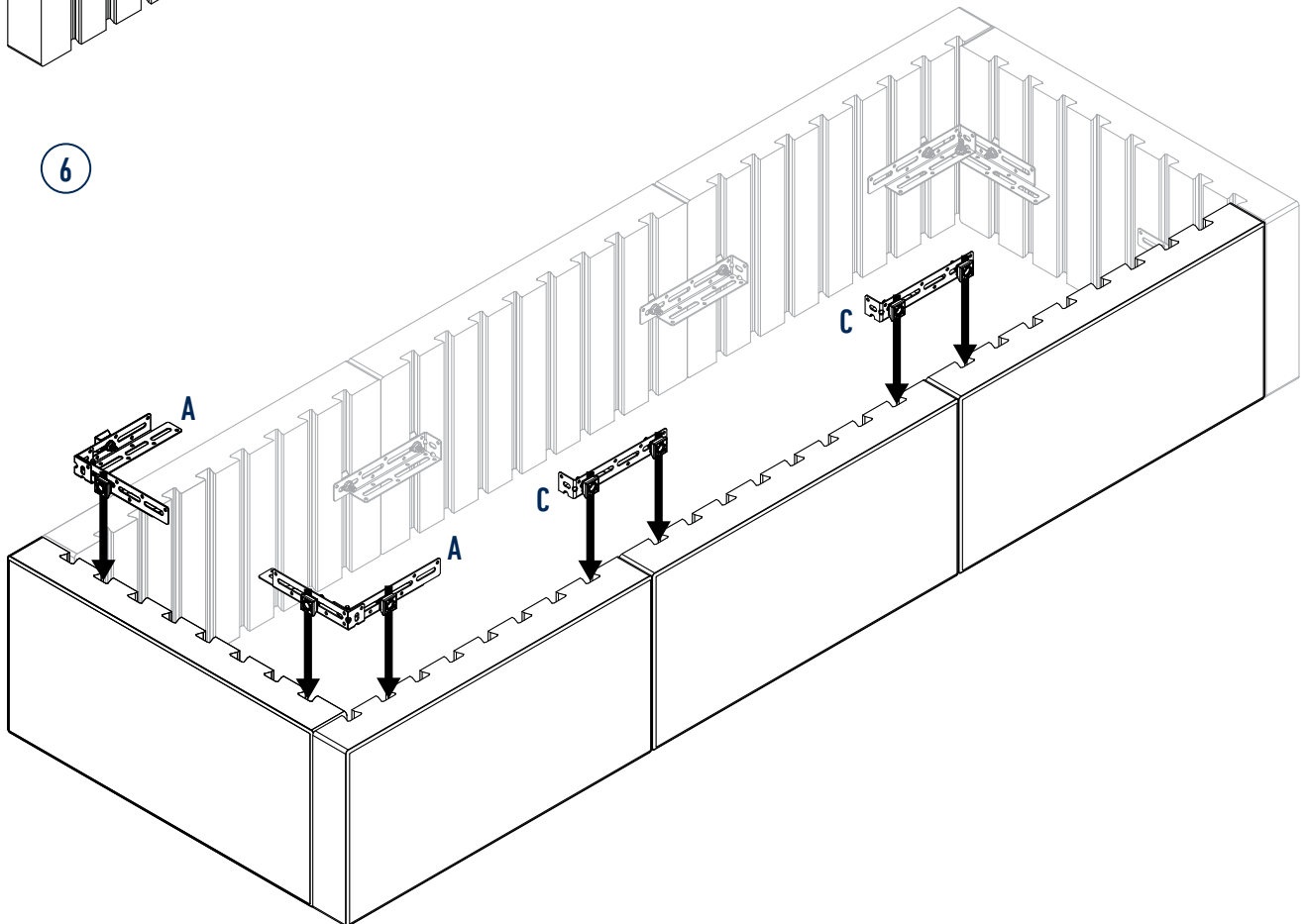



DESIGNFORMS™

6 FT BENCH - WOOD TOP

7

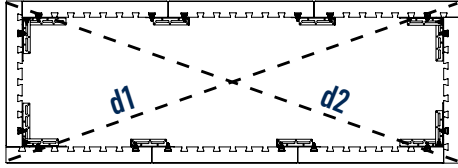

$d1 = d2$

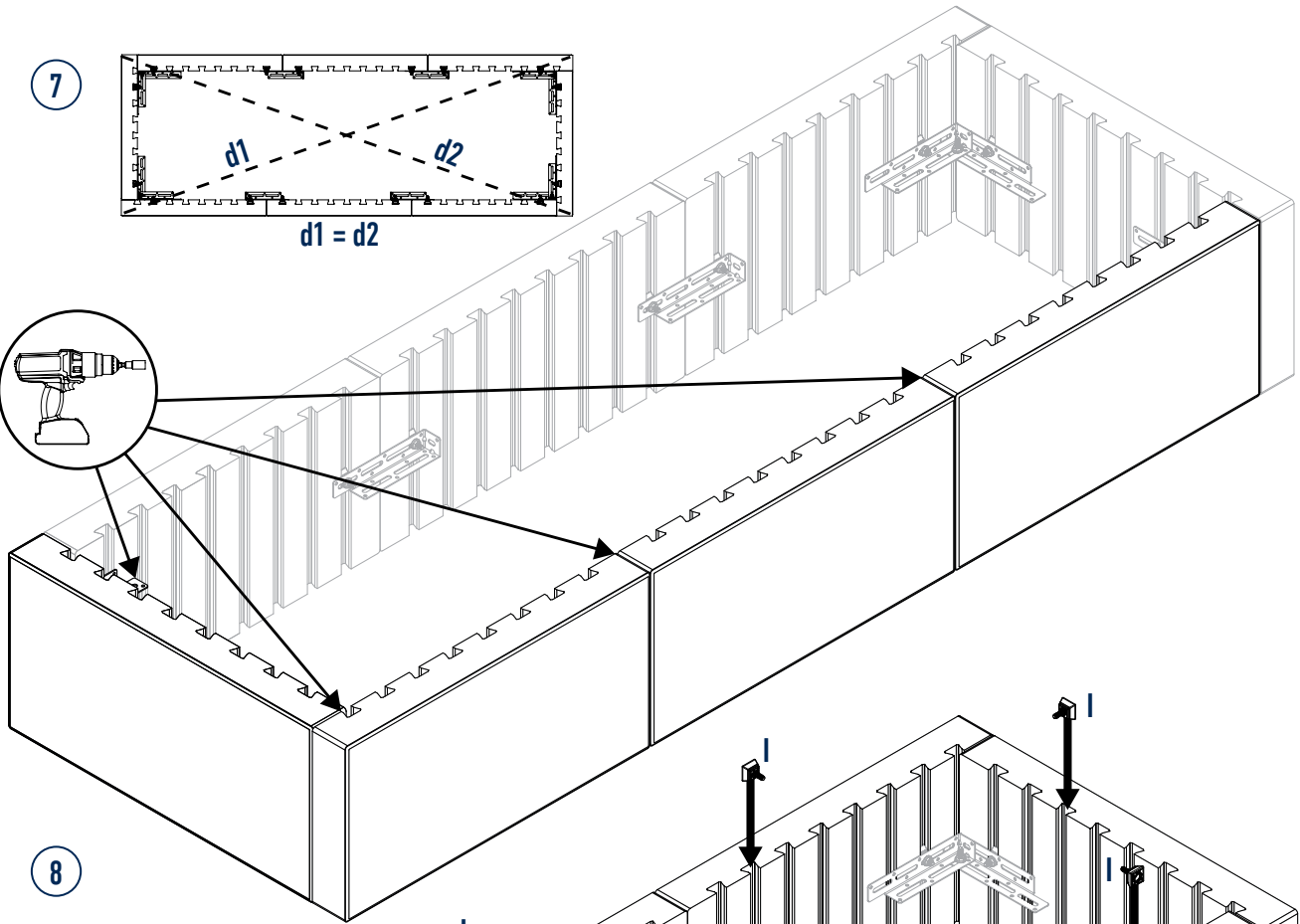
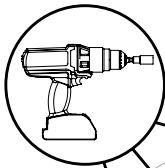

8

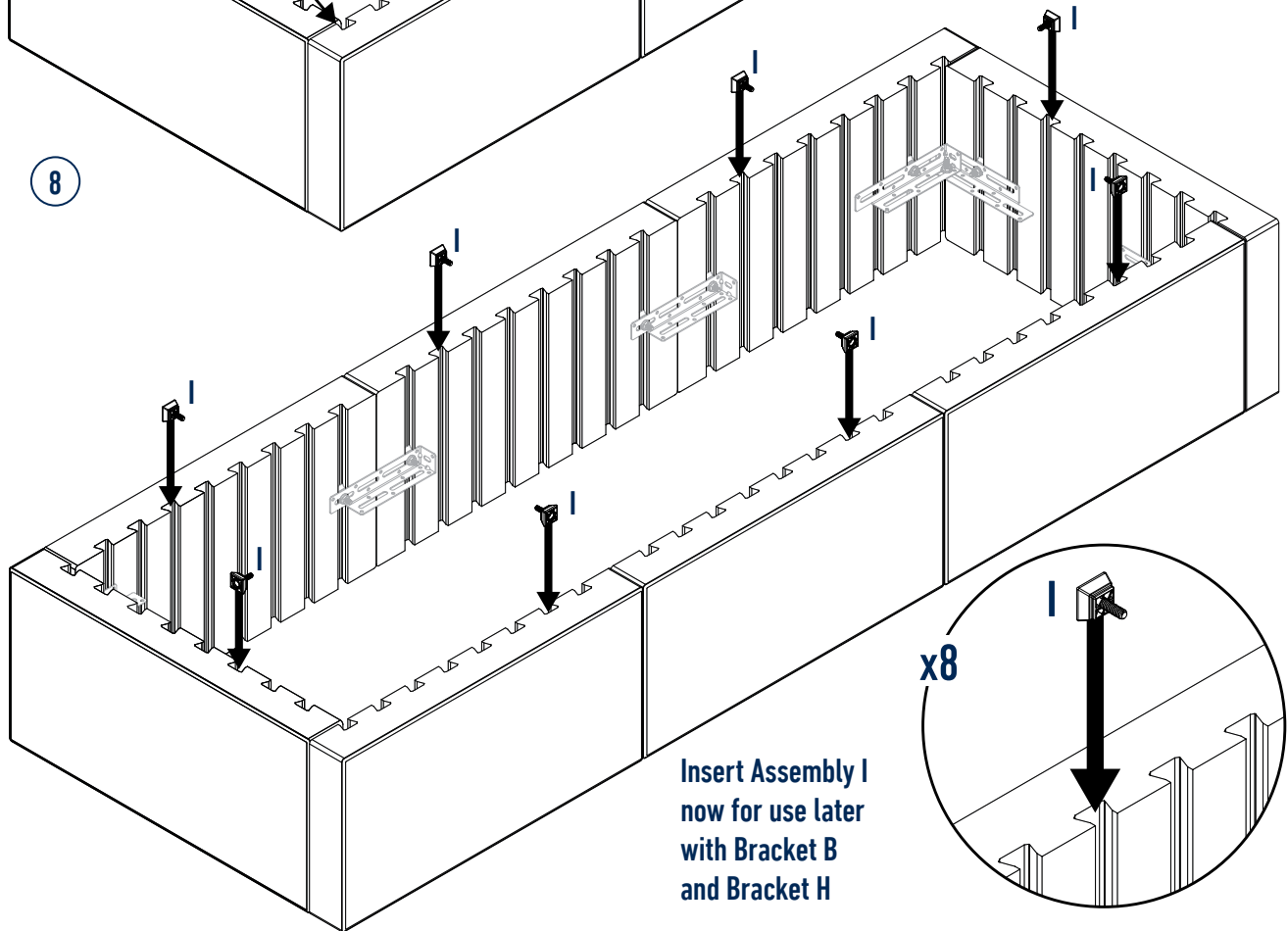

x8

Insert Assembly I
now for use later
with Bracket B
and Bracket H

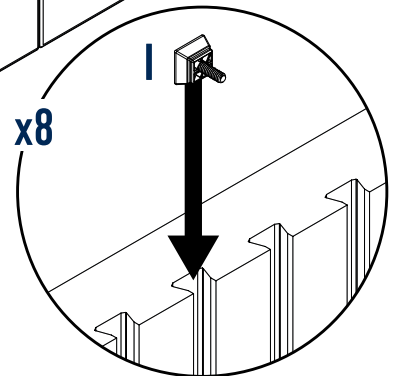



DESIGNFORMS™

6 FT BENCH
- WOOD TOP

9

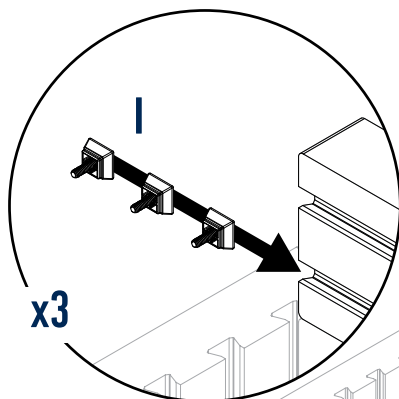

10

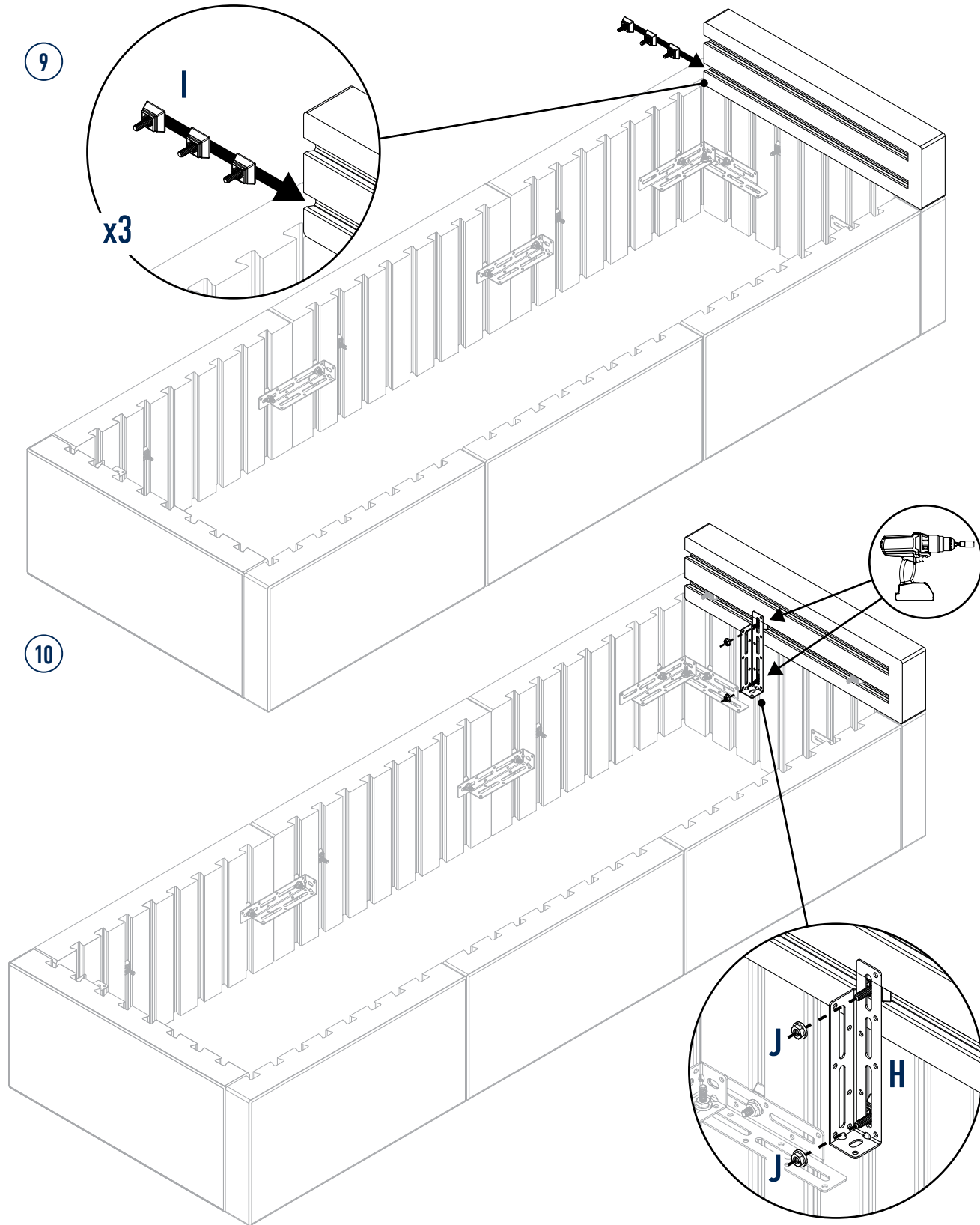



DESIGNFORMS™

6 FT BENCH
- WOOD TOP

11

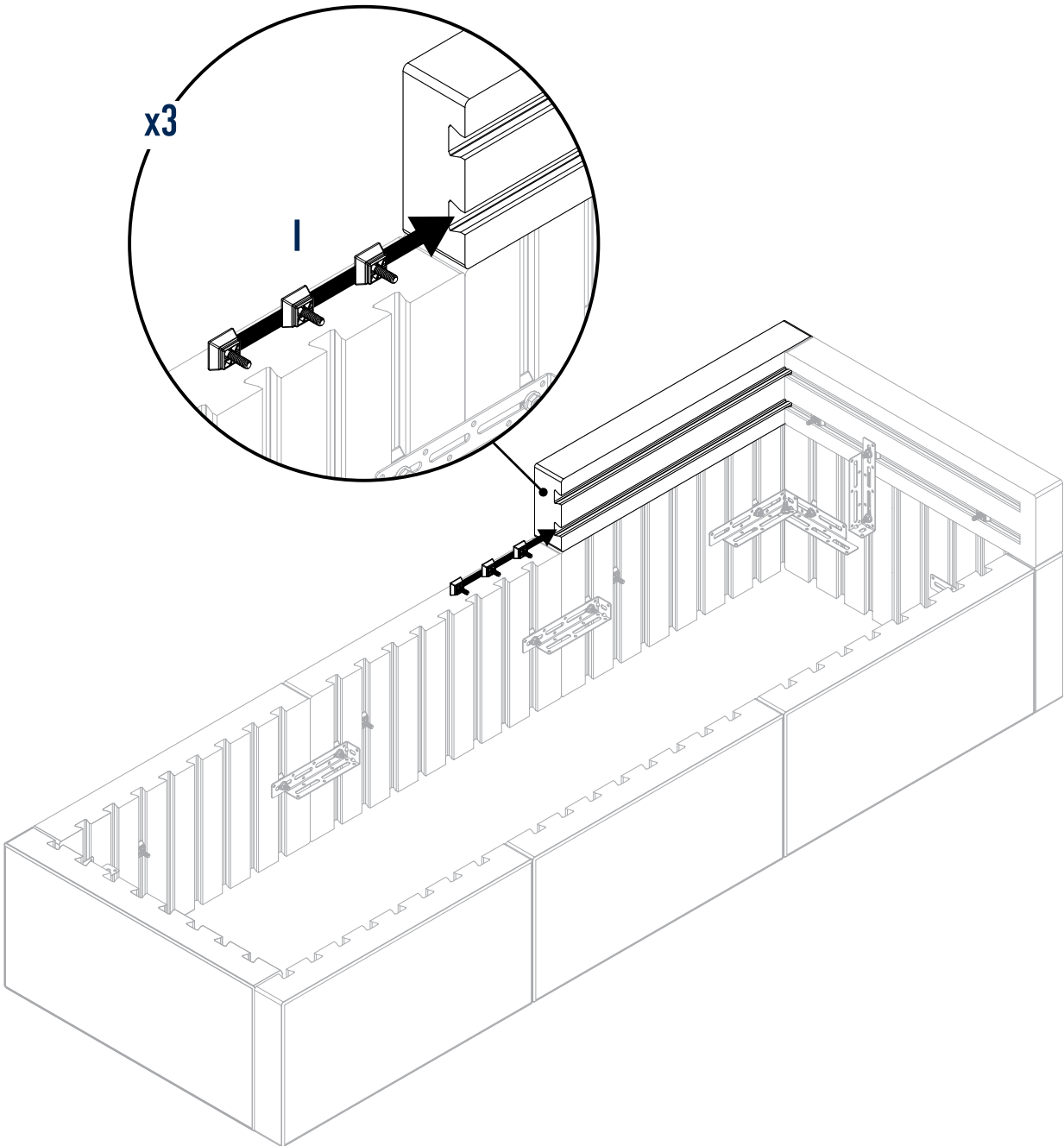



12

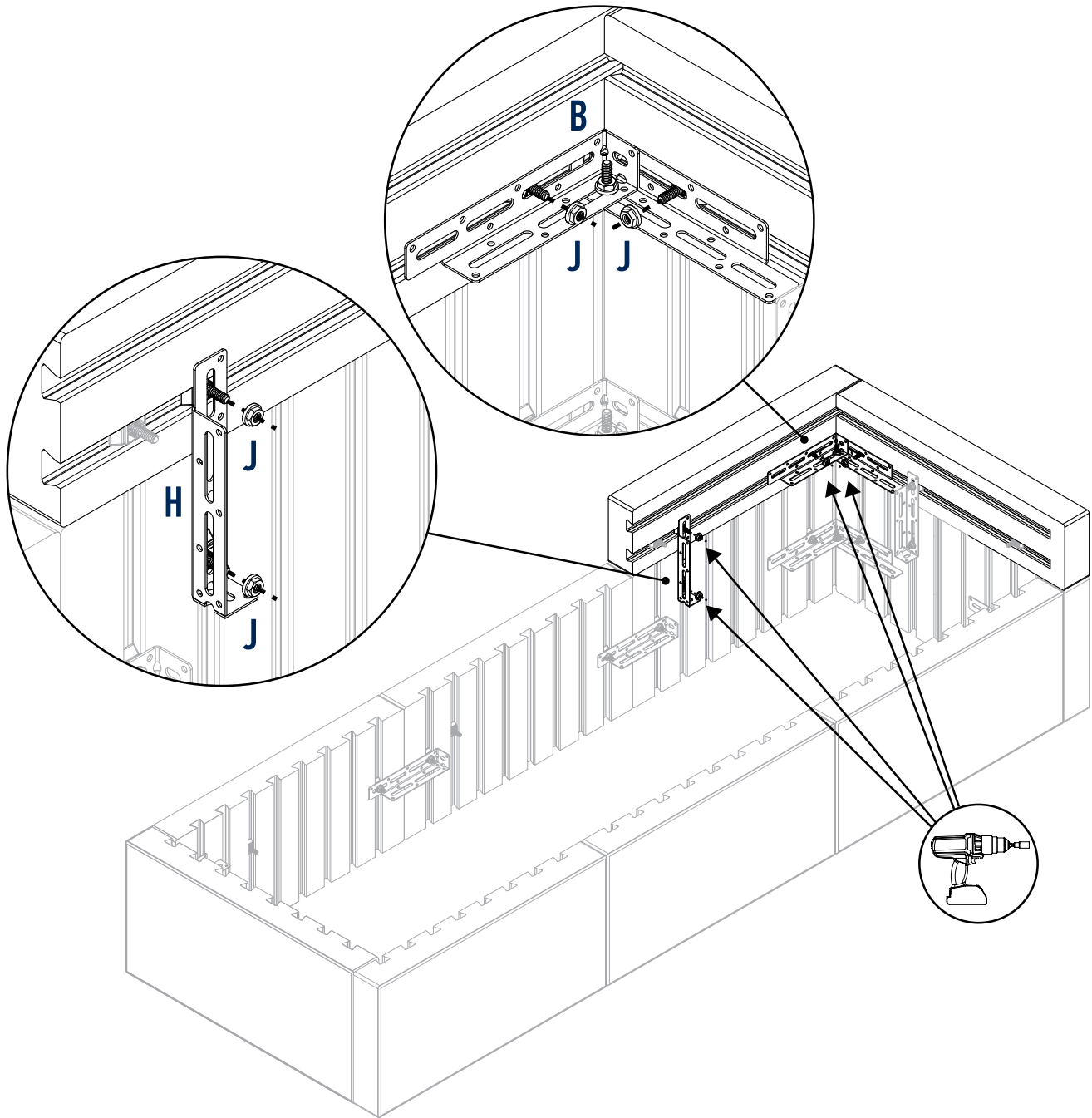



DESIGNFORMS™

6 FT BENCH
- WOOD TOP

13

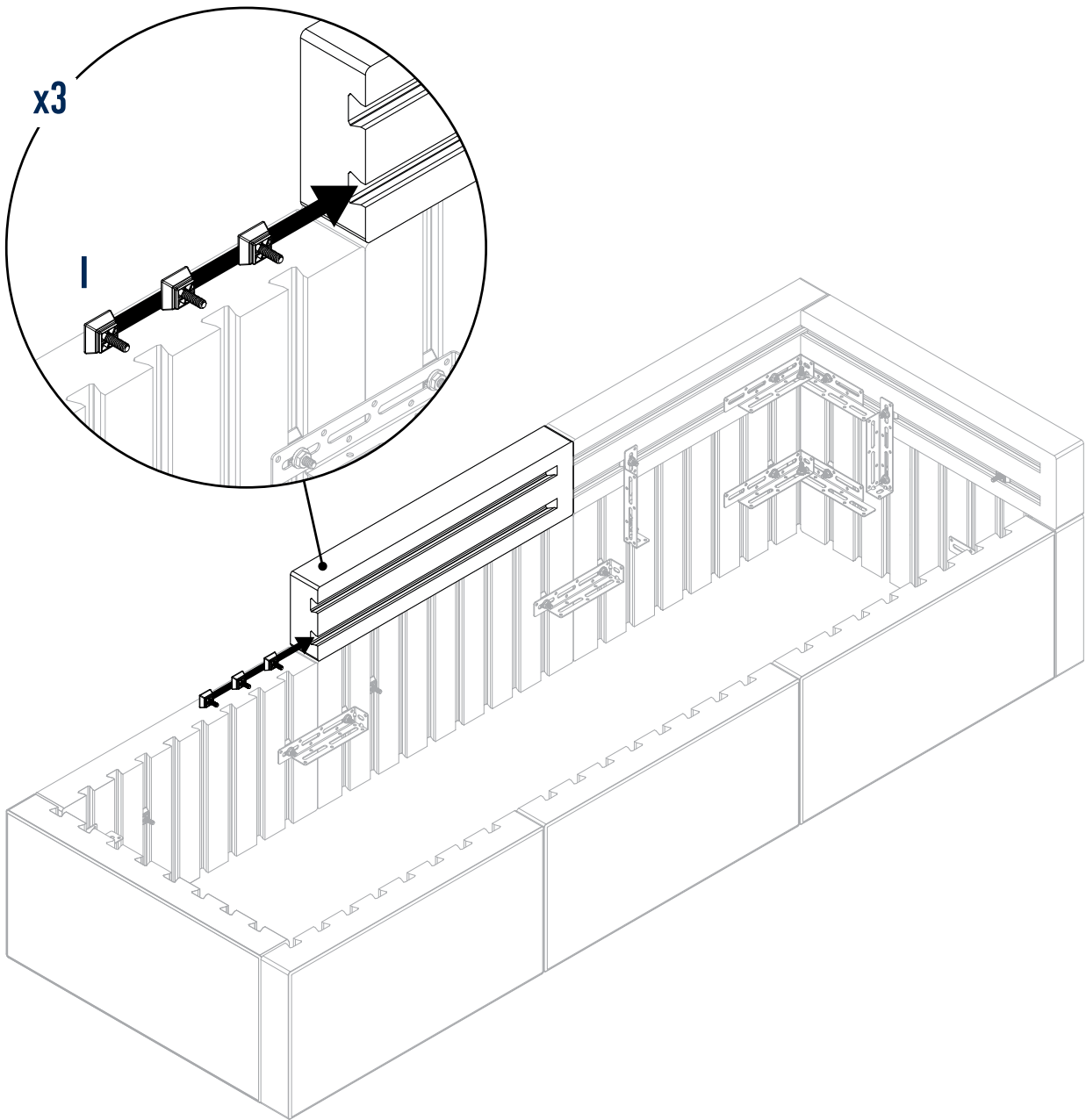



14

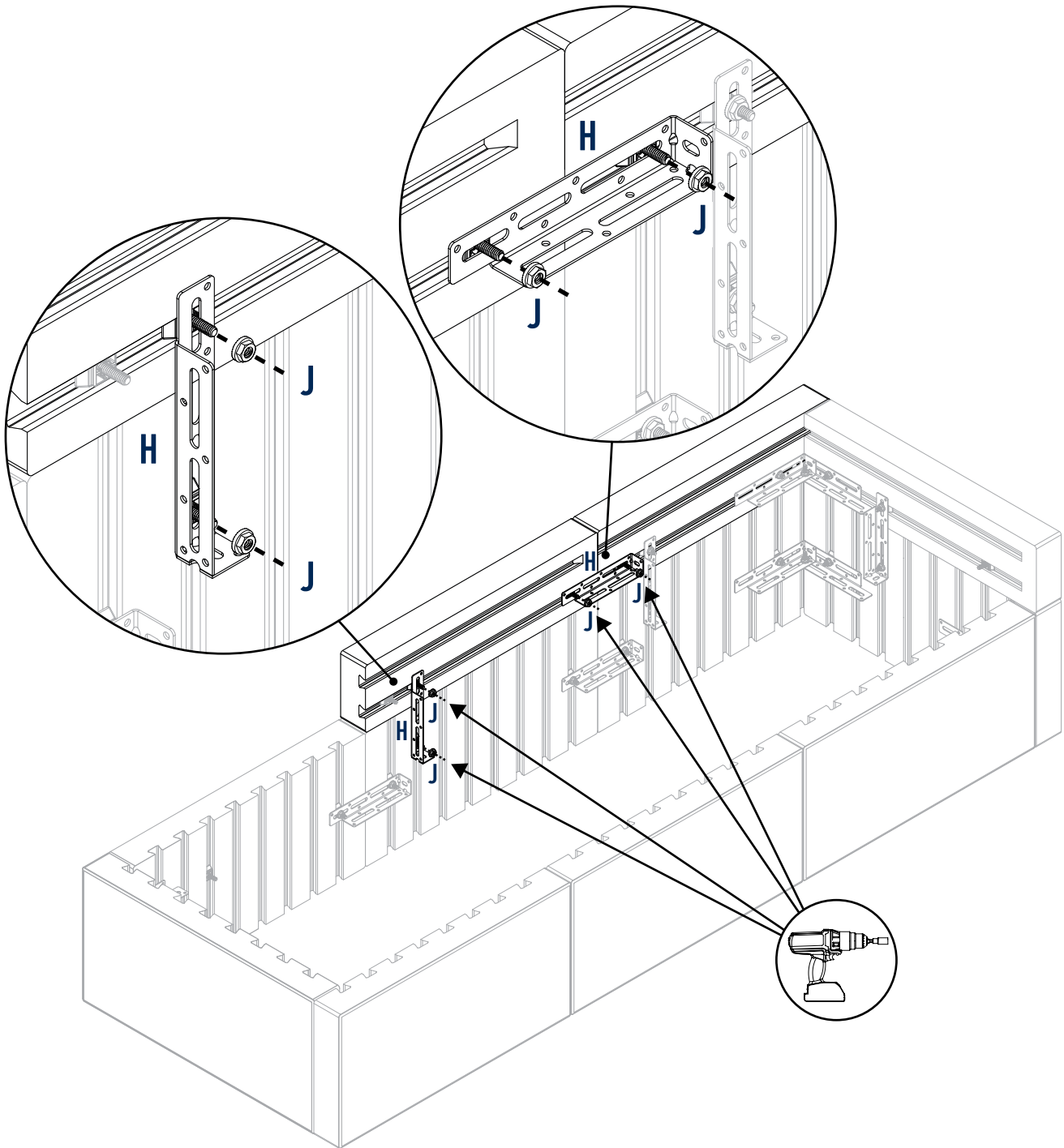



15

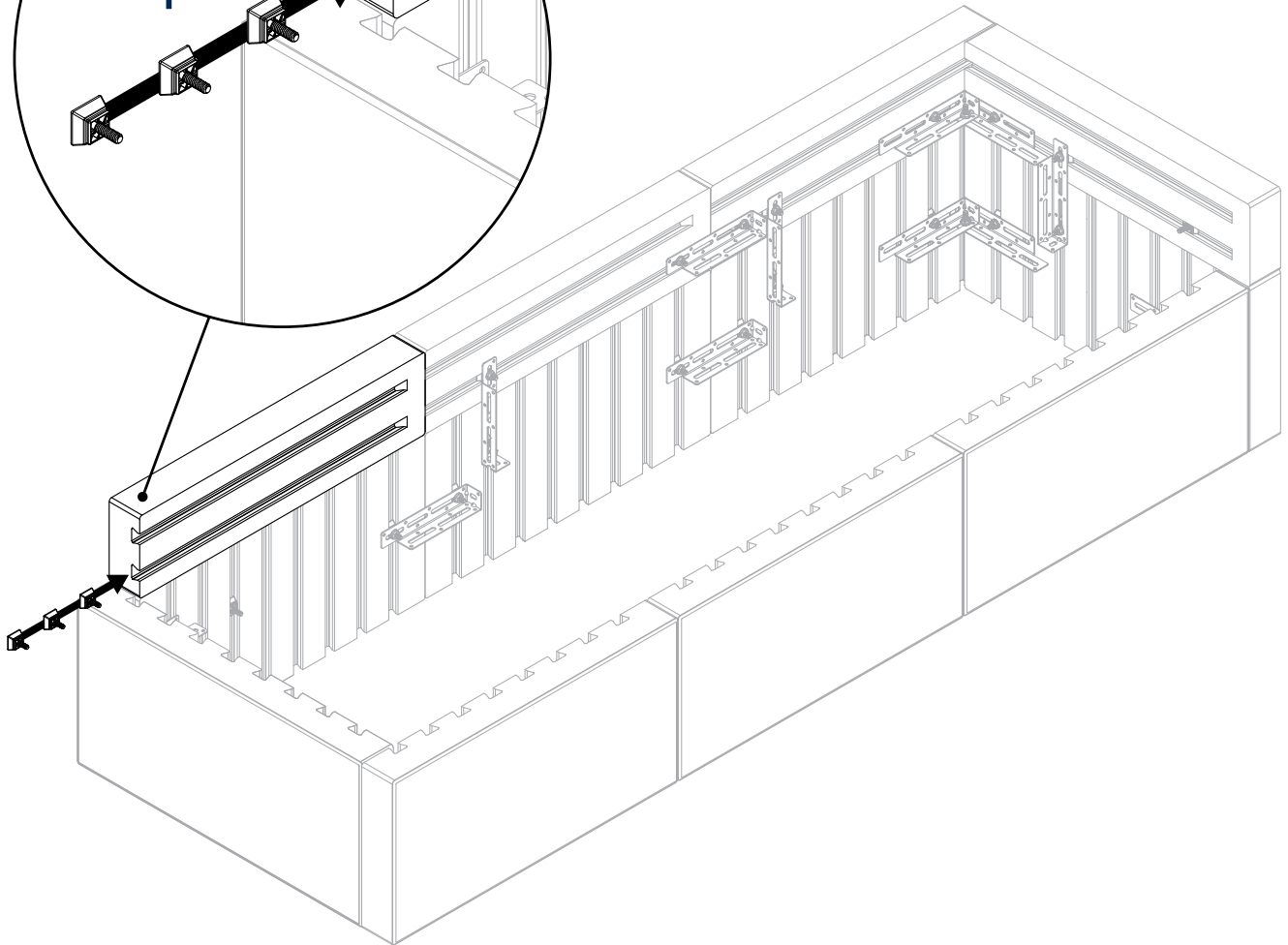
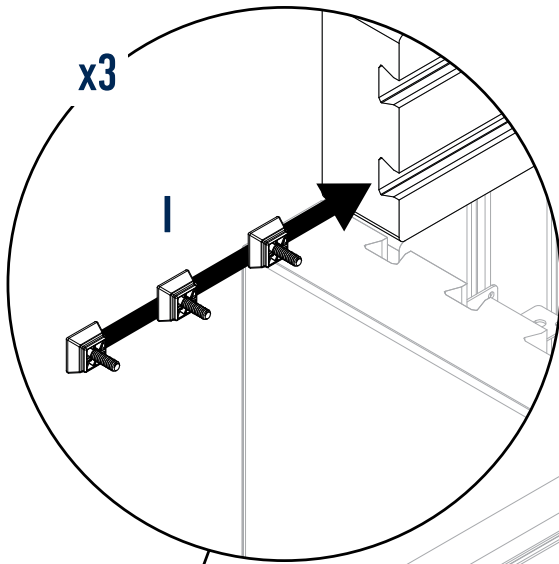



16

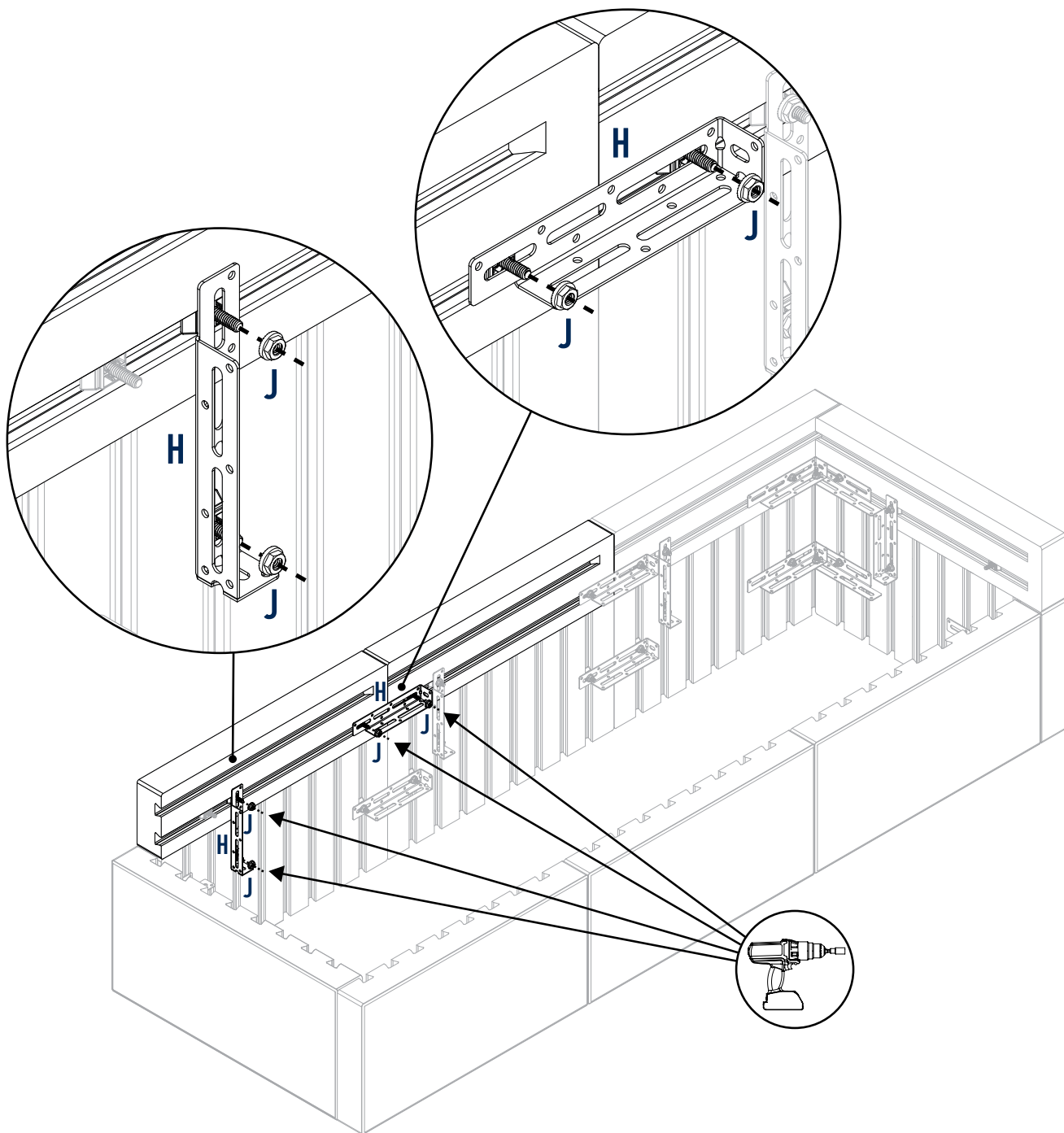



17

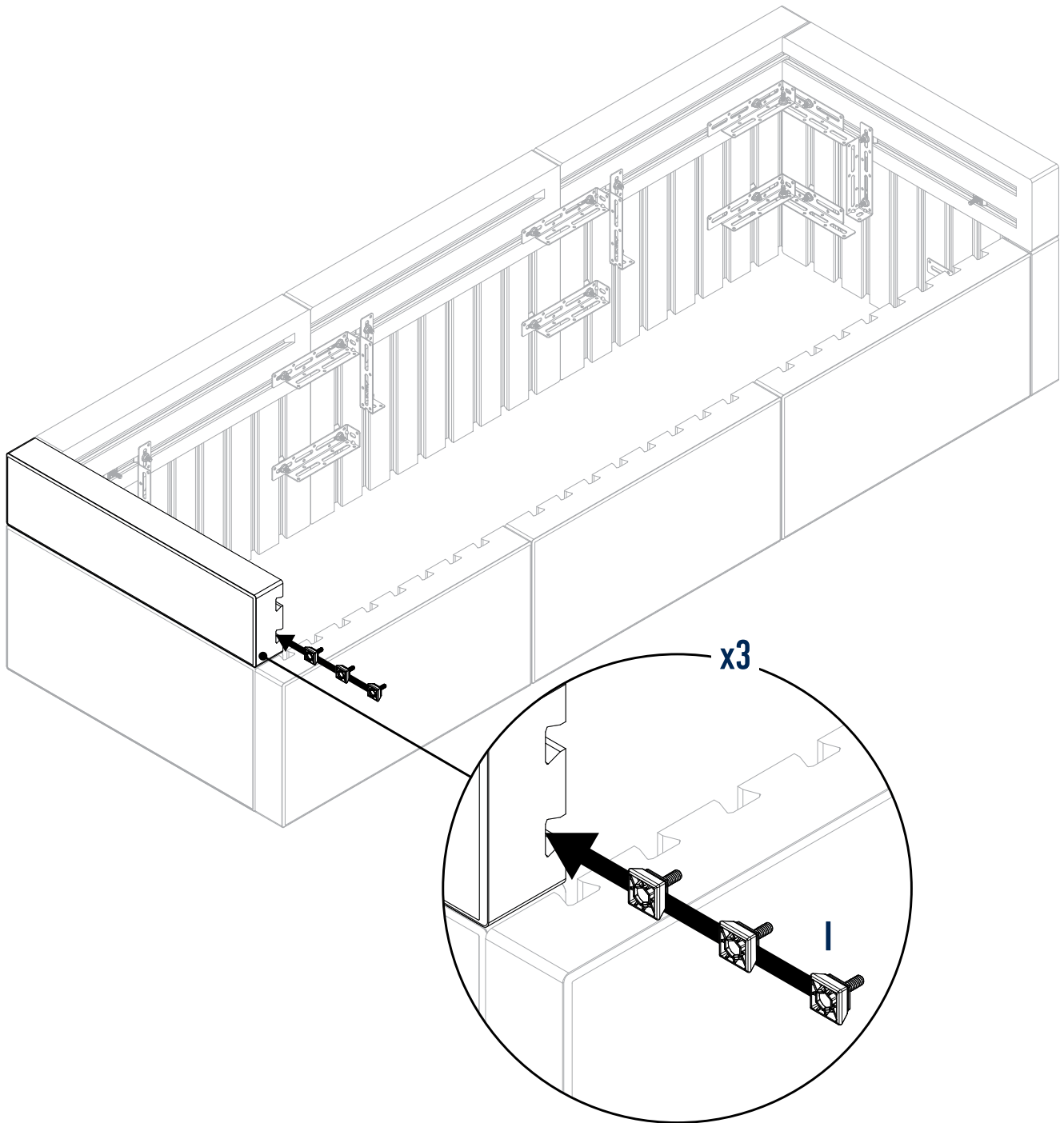

18

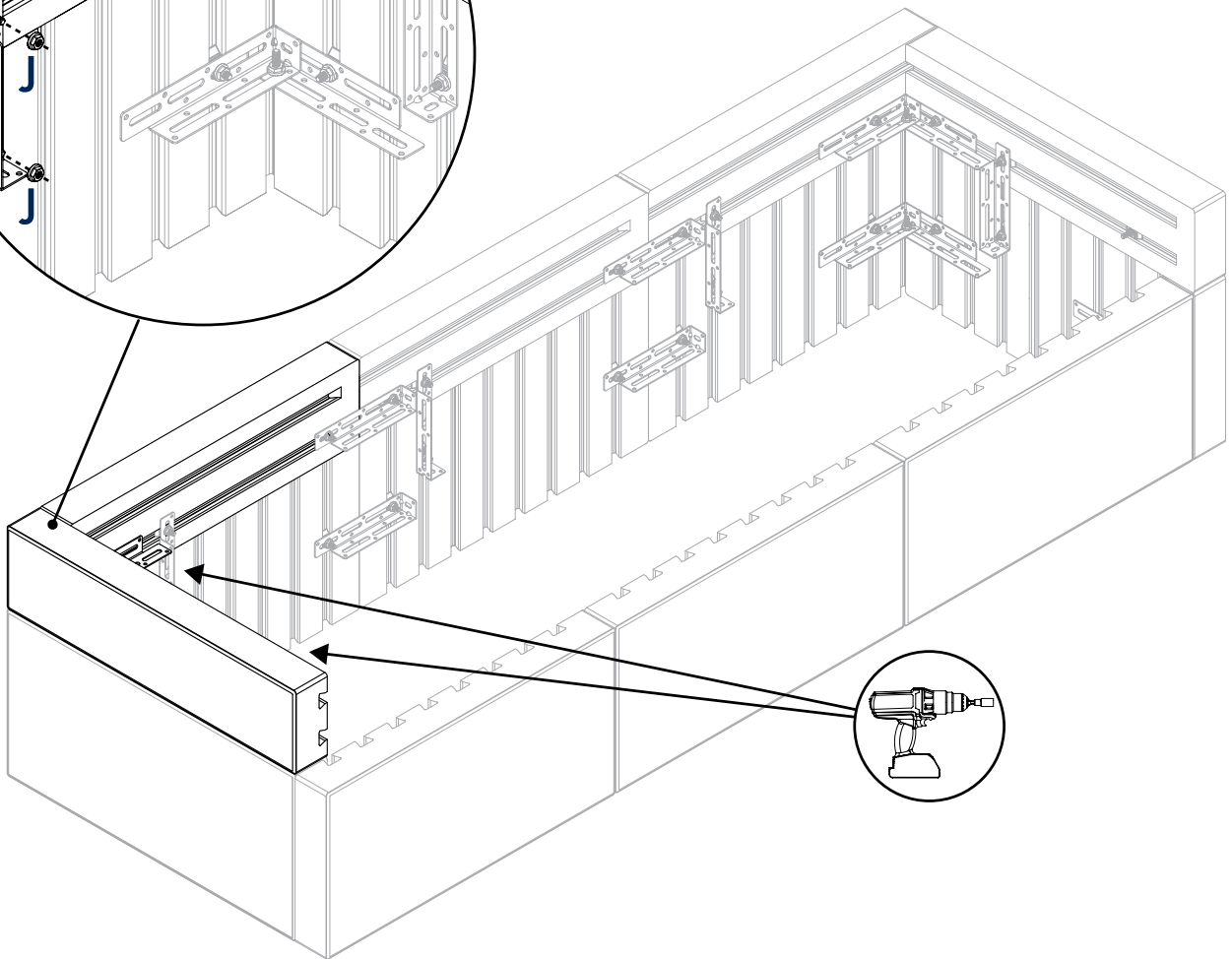
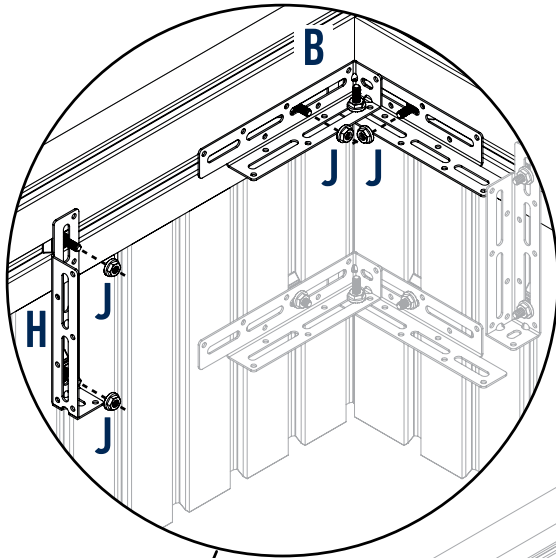



19

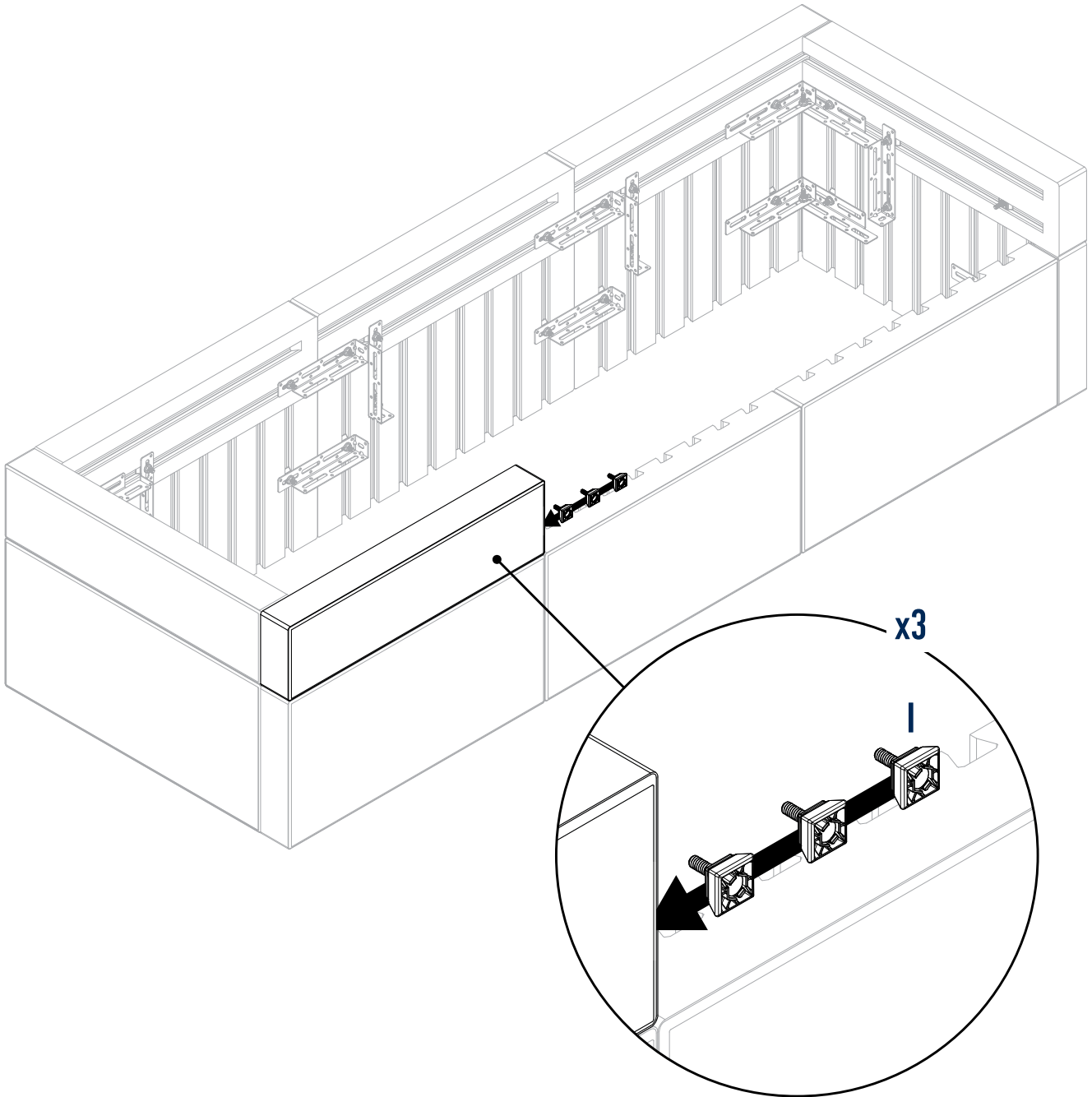



20

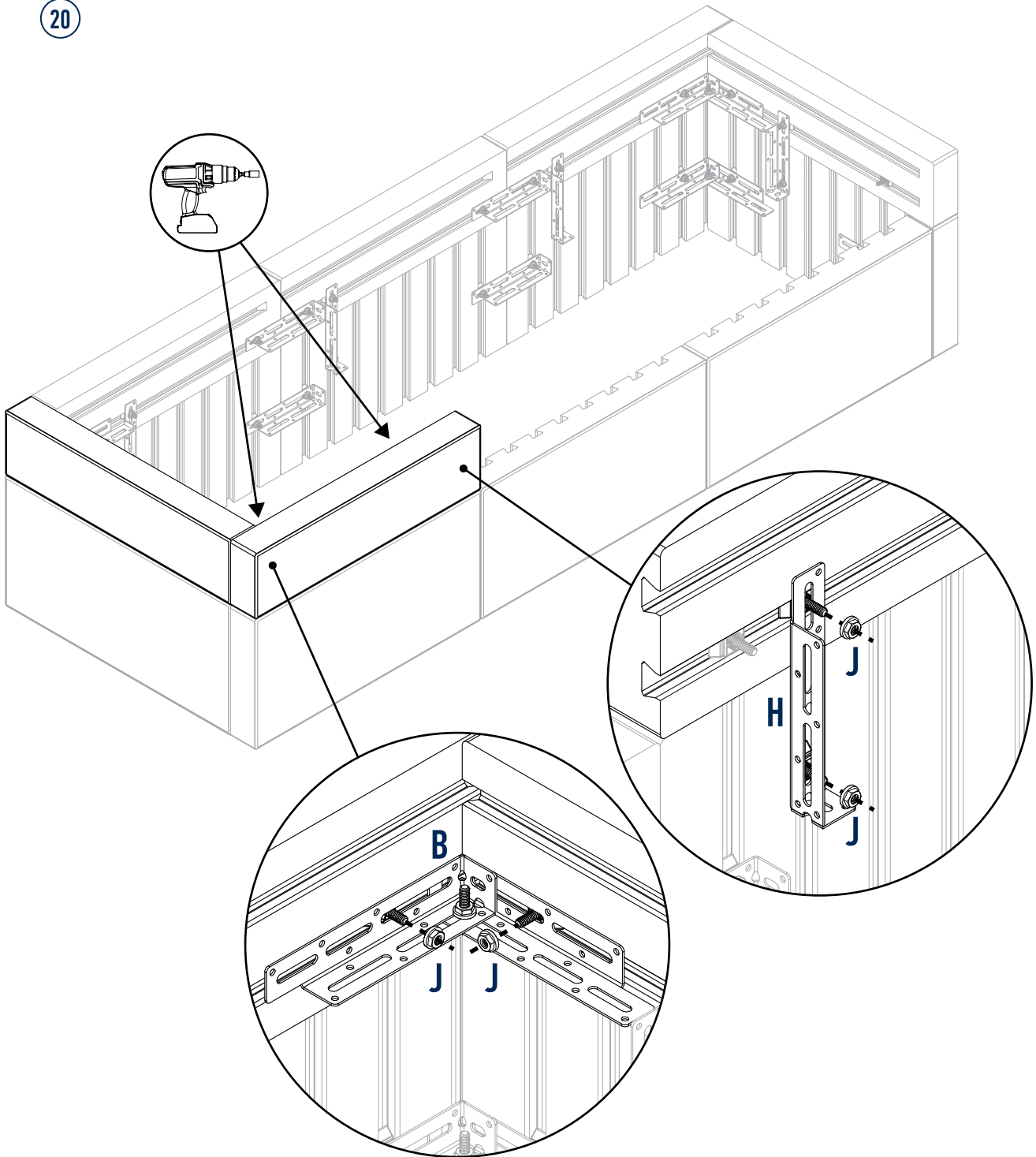



21

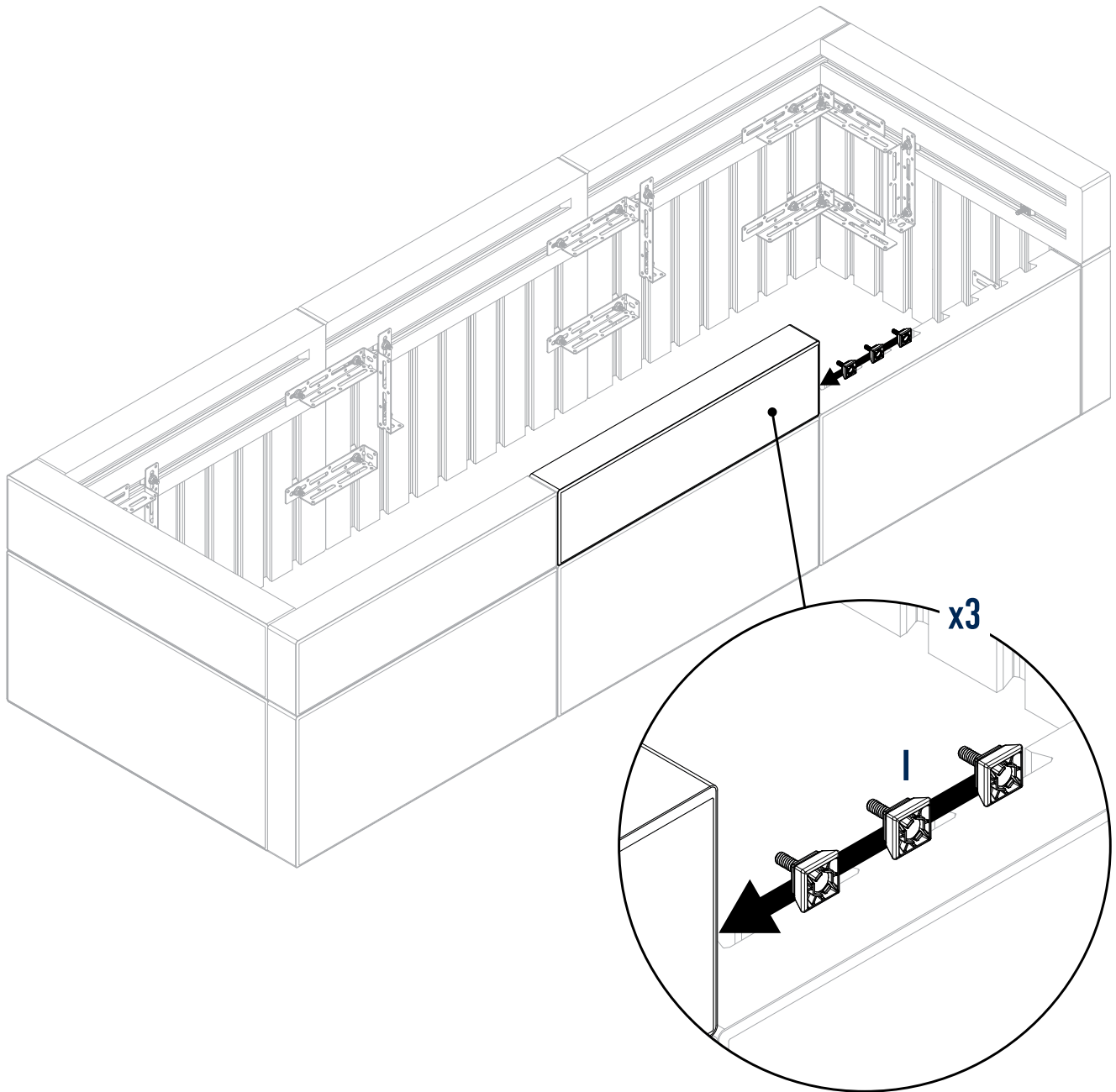

22

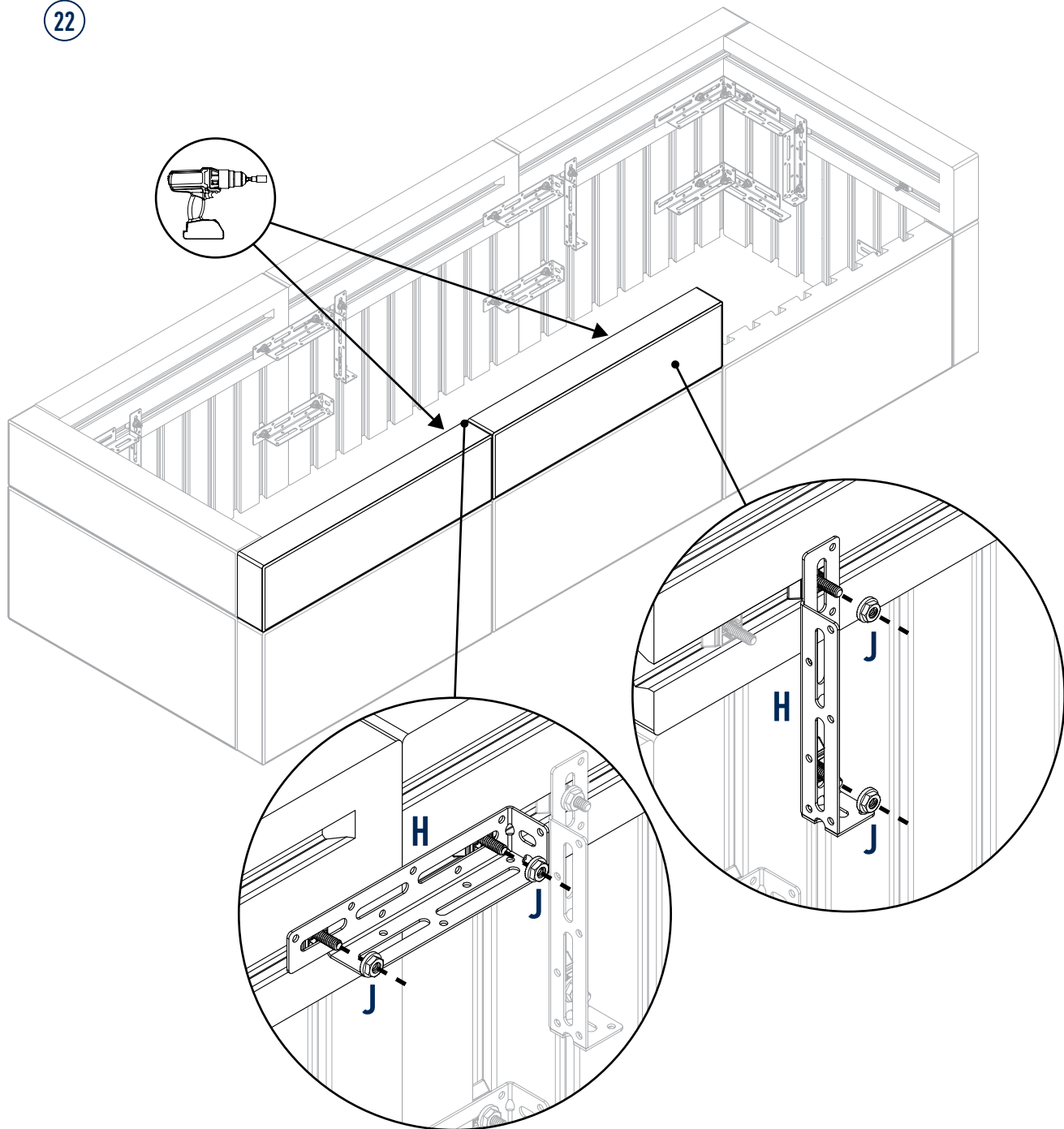



23

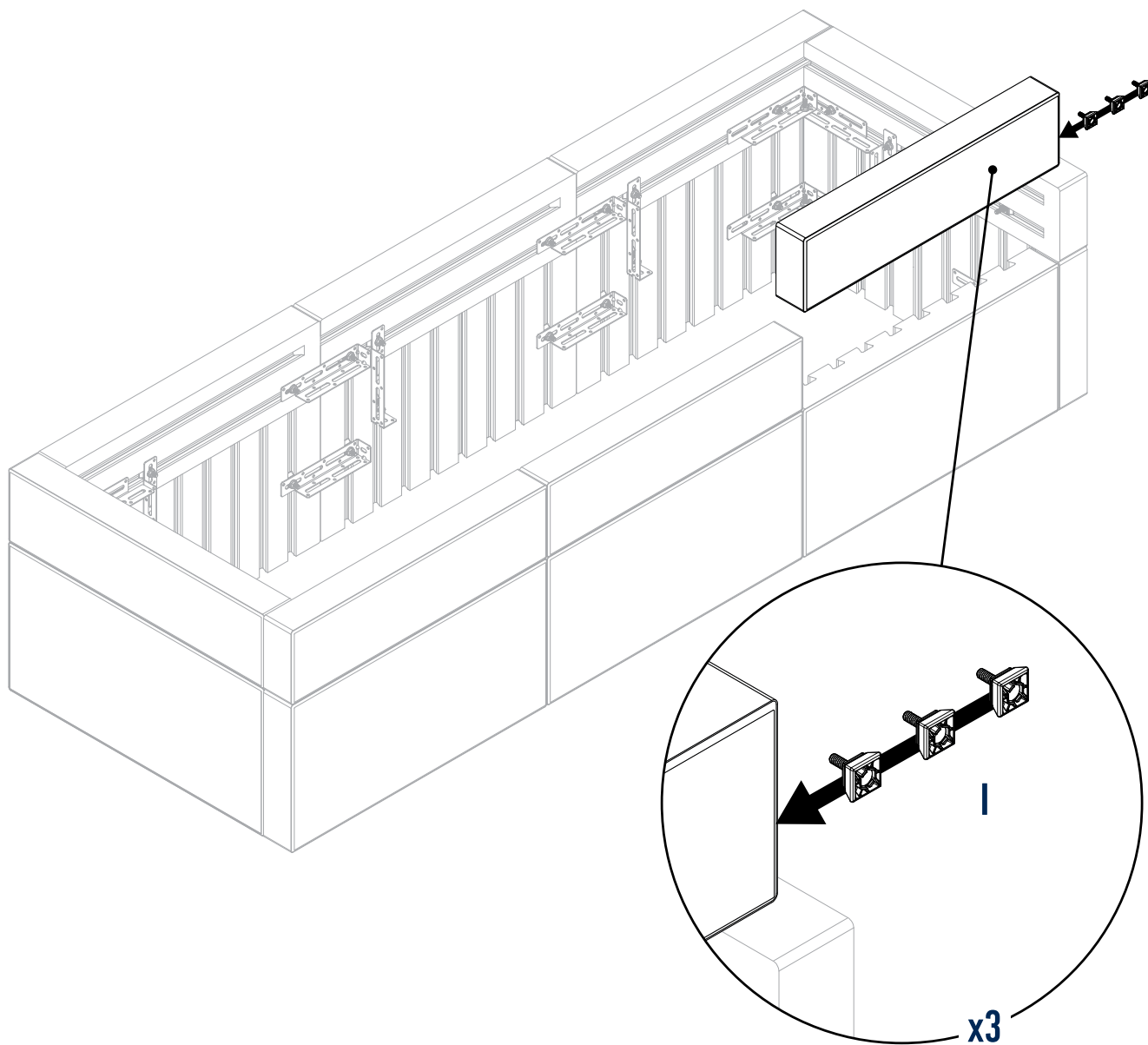



24

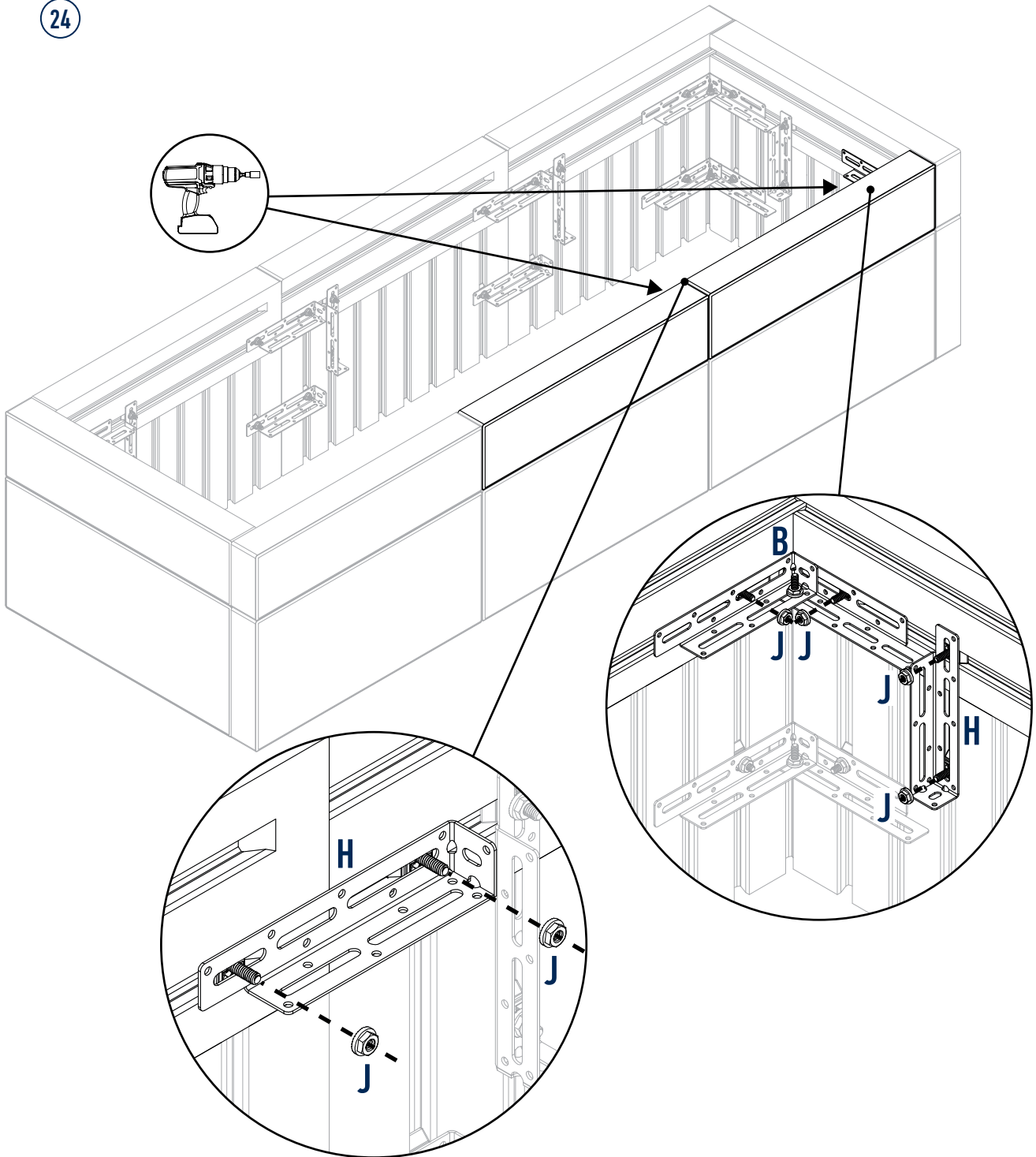



25

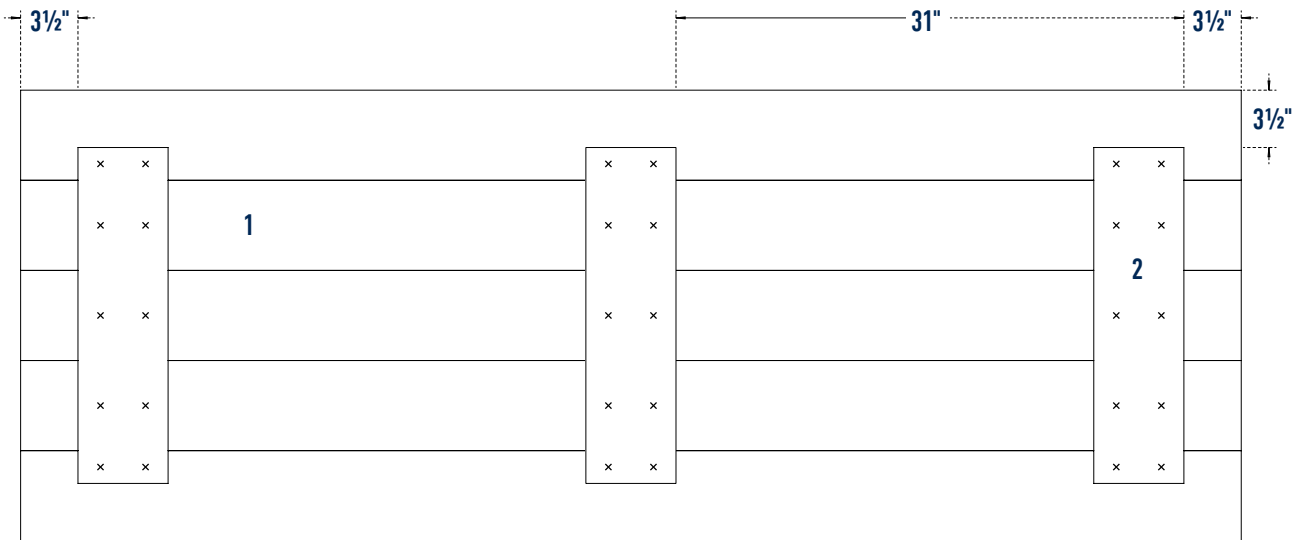

26

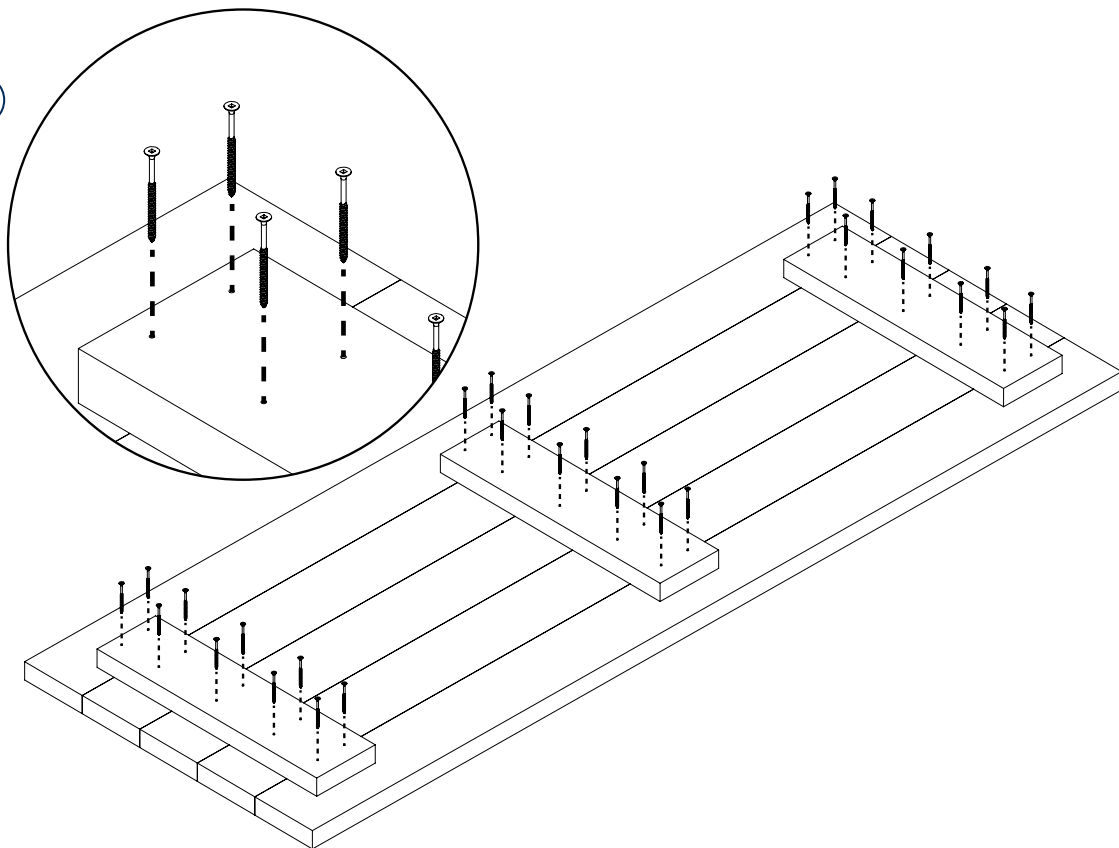



27

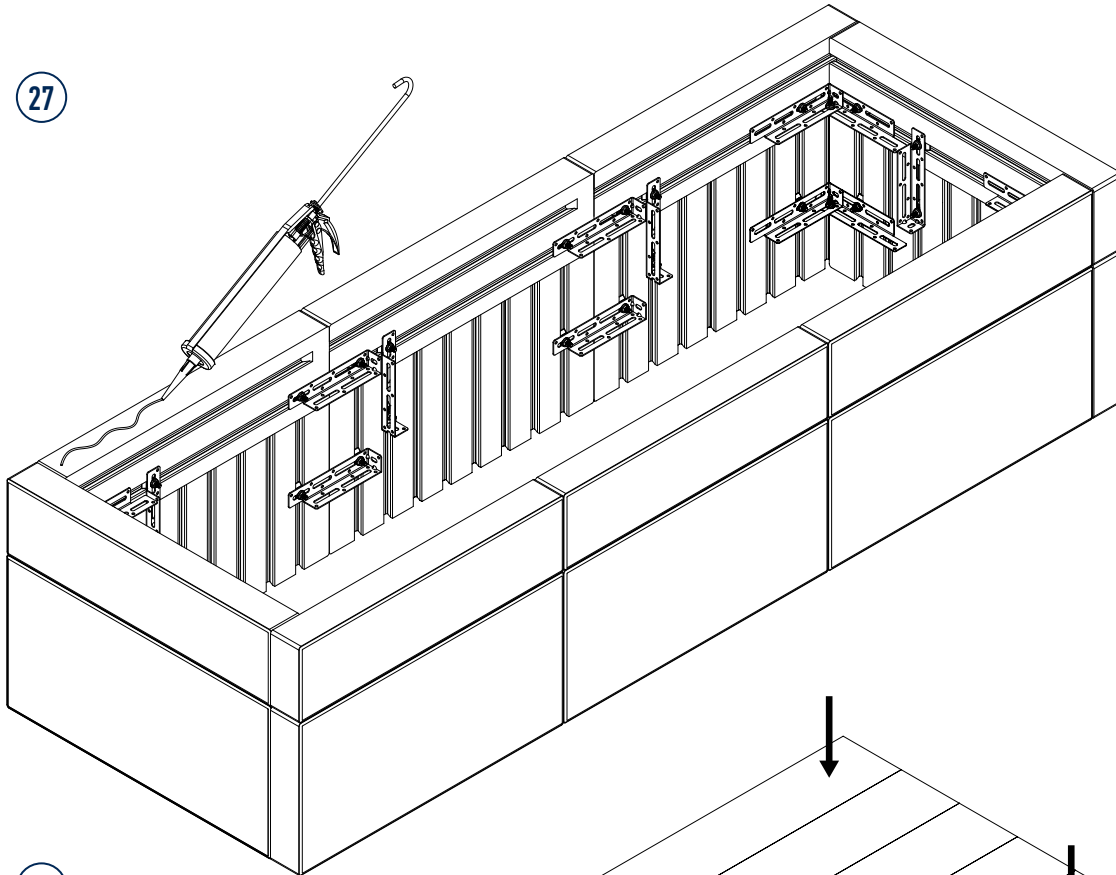

28

