

13. RECESSED WOOD FIRE PIT

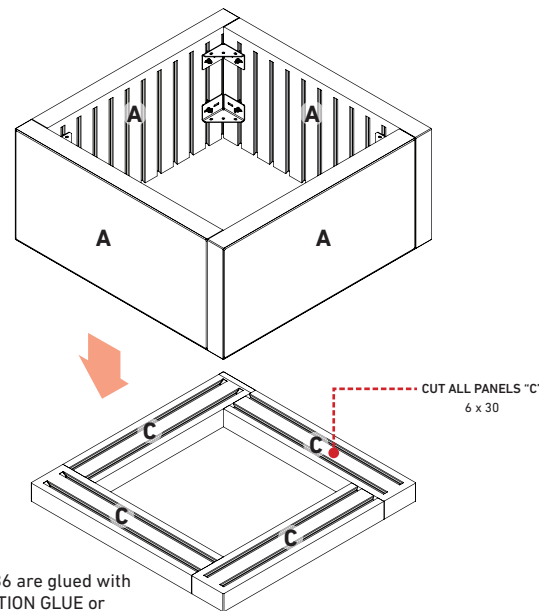

INTERIOR VIEW



NOTE: The panels 18 x 36 are glued with 6 x 36 using CONSTRUCTION GLUE or STRUCTURE BOND

REQUIRED PANELS

	18 x 36 PANEL	4x
	18 x 36 PANEL	0x
	6 x 36 PANEL	4x
	6 x 36 PANEL	0x

IMPORTANT: 18 x 36 panels are sold in pair/layer or in full pallet only. 6 x 36 panels are sold per unit or in layer or in full pallet.

FRONT VIEW

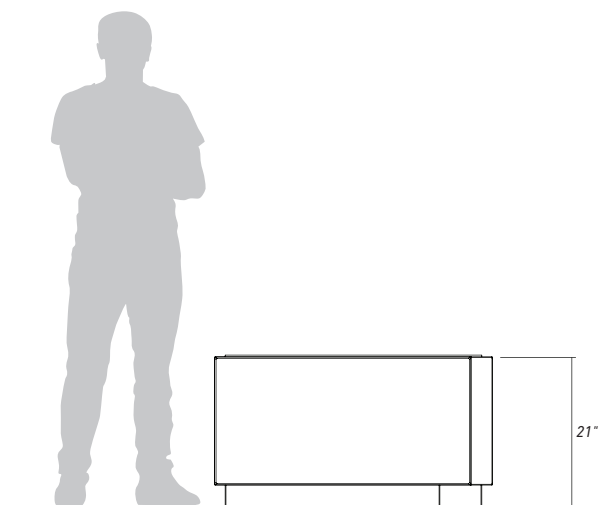

TOP VIEW

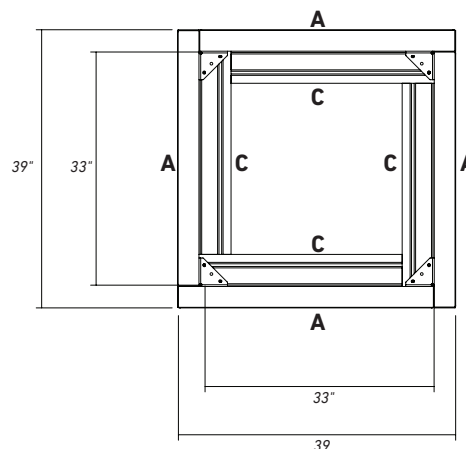

REQUIRED HARDWARE

	ANCHOR SLIDE AND NUT	16x
	JOINING PLATE	0x
	OUTER CORNER	8x
	INNER CORNER	0x
	STRETCHER	0x

IMPORTANT: It is recommended to follow the burner manufacturer's specifications for ventilation. Belgard is not responsible for the conformity of connections, clearances and ventilation. Metal liner plate and accessories are not included.